

TTP-247 / TTP-345
TTP-245 Plus / TTP-343 Plus

**THERMAL TRANSFER / DIRECT THERMAL
BAR CODE PRINTER**

**SERVICE
MANUAL**

Contents

1. FUNDAMENTAL OF THE SYSTEM	1
1.1. Overview.....	1
1.1.1. Front View	1
1.1.2. Rear View	2
1.2. Specification	3
1.2.1. Printer (TTP-245 Plus / TTP-343 Plus)	3
1.2.2. Printer (TTP-247 / TTP-345)	6
1.2.3. LED.....	10
1.2.4. Button.....	10
1.3. Supply Specification	14
1.3.1. Paper	14
1.3.2. Ribbon.....	14
2. ELECTRONICS	15
2.1 Summary of Board Connectors.....	15
2.2 Pin Configuration.....	19
3. REPLACE IMPORTANT PARTS	21
3.1. Replacing Top Cover	21
3.2. Replacing Top Inner Cover.....	23
3.3. Replacing Lower Cover.....	25
3.4. Replacing Main Board.....	26
3.5. Replacing Platen Assembly	27
3.6. Replacing the Stepping Motor Bracket / Metal Assembly and Stepping Motor	28
3.7. Replacing Label Guide & Gap Sensor Assembly	30
3.8. Replacing Black Mark Sensor Assembly	32
3.9. Replacing Print Head Assembly	33
3.10. Replacing Head Open Micro Switch	34
3.11. Replacing Ribbon Motor and Ribbon Sensor	36
3.12. Replacing Feed Button and Feed Button PCB.....	38
3.13. Install SD Memory Card	39
3.14. Install Peel off Module (Option)	41
3.15. Loading the Label in Peel-off Mode	43
3.16. Install Cutter Module (Option).....	45
3.17. Loading Label in Cutter Mode	49
3.18. Internal Ethernet Interface Installation (Option)	50
4. Power on Utilities	52

4.1 Ribbon and Gap/Black Mark Sensor Calibration	52
4.2 Gap/Black Mark Calibration ; Self-test ; Dump mode	53
4.3 Printer Initialization.....	56
4.4 Black Mark Sensor Calibration	57
4.5 Gap Sensor Calibration.....	57
4.6 Skip AUTO.BAS	57
5. GAP AND BLACK MARK SENSOR SELECTION.....	59
6. BIOS Update	59
7. DIAGNOSTIC TOOL.....	60
7.1 Start the Diagnostic Tool	60
7.2 Printer Function (Calibrate sensor, Ethernet setup, RTC setup.....) ..	61
8. TROUBLESHOOTING.....	62
9. MAINTENANCE	66
UPDATE HISTORY	68

1. FUNDAMENTAL OF THE SYSTEM

1.1. Overview

1.1.1. Front View



Fig. 1.1.1 Front View

1.1.2. Rear View

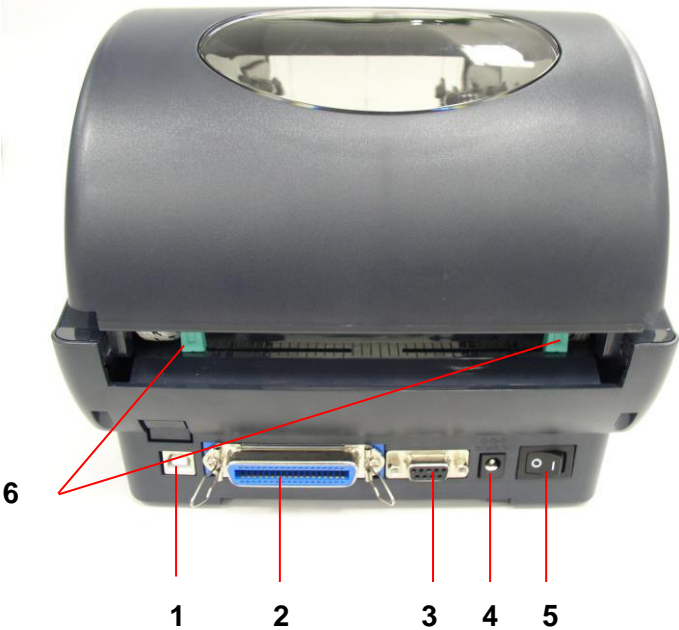

- 1. **USB Interface**
- 2. **Centronics Interface**
- 3. **RS-232 Interface**
- 4. **Power Jack**
- 5. **Power Switch**
- 6. **Rear Paper Guide**

Fig. 1.1.2 Rear View

1.2. Specification

1.2.1. Printer (TTP-245 Plus / TTP-343 Plus)

Item \ Printer model	TTP-245 Plus	TTP-343 Plus
Resolution	203 DPI	300 DPI
Printing method	Thermal Transfer & Direct Thermal	
Print speed	2, 3, 4, 5 ips. 2, 3 ips for peel model	2, 3 ips
Max. print width	108 mm (4.25")	104 mm (4.09")
Max. print length	2286 mm (90")	1016 mm (40")
Enclosure	Double-walled plastic	
Physical dimension	314mm (L) x 213mm (W) x 188mm (H)	
Ribbon capacity	300 meter, 1" core	
Label roll capacity	5" OD	
Processor	32-bit RISC high performance processor	
Memory	<ul style="list-style-type: none"> ■ 2MB Flash memory ■ 8MB DRAM ■ SD card slot for memory expansion 	
Interface	<ul style="list-style-type: none"> ■ RS-232 (max. 115200 bps) ■ Centronics ■ USB 2.0 (Full speed mode) 	
Power	External universal switching power supply <ul style="list-style-type: none"> ■ Input: AC 100-240V ■ Output: DC 24V 3.75A 	
Operation switch, button	One power switch & feed button	
Sensors	<ul style="list-style-type: none"> ■ Gap transmissive sensor (offset 6 mm from liner edge) ■ Black mark reflective sensor (position adjustable) ■ Head open ■ Ribbon end sensor 	

Internal font	<ul style="list-style-type: none"> ■ 8 alpha-numeric bitmap fonts ■ One Monotype Imaging® CG Triumvirate Bold Condensed scalable font
Code Page	<ul style="list-style-type: none"> ■ Codepage 437 (English - US) ■ Codepage 850 (Latin 1) ■ Codepage 852 (Latin 2) ■ Codepage 860 (Portuguese) ■ Codepage 863 (French Canadian) ■ Codepage 865 (Nordic) ■ Codepage 857 (Turkish) ■ Codepage 861 (Iceland) ■ Codepage 1250 (Latin 2) ■ Codepage 1251 (Cyrillic) ■ Codepage 1252 (Latin 1) ■ Codepage 1253 (Greek) ■ Codepage 1254 (Turkish) ■ Codepage 1257 (Baltic) ■ Codepage 1258 (Vietnam) ■ ISO-8859-1: Latin-1 (Western European) ■ ISO-8859-2: Latin-2 (Central European) ■ ISO-8859-3: Latin-3 (South European) ■ ISO-8859-4: Latin-4 (North European) ■ ISO-8859-5: Cyrillic ■ ISO-8859-7: Greek ■ ISO-8859-9: Turkish ■ ISO-8859-10: Nordic ■ ISO-8859-15: Latin9
Bar code	<p>1D bar code Code 39, Code 93, Code128UCC, Code128 subset A, B, C, Codabar, Interleave 2 of 5, EAN-8, EAN-13, EAN-128, UPC-A, UPC-E, EAN and UPC 2(5) digits add-on, MSI, PLESSEY, POSTNET, China POST</p> <p>2D bar code PDF-417, Maxicode, DataMatrix, QR code</p>
Font & barcode rotation	0, 90, 180,270 degree
Command set	TSPL-EZ

Media type	Continuous, die-cut, black mark, fan-fold, notch	
Media wound type	Outside wound	
Media width	20~112mm (0.78" ~ 4.4")	
Media thickness	0.06~0.19 mm (2.3~7.4 mil), max. 150g/m ²	
Media core diameter	25.4~76.2 mm (1"~3")	
Label length	Min. 10 mm (0.4")	
Label length (peeler mode)	25.4~152.4 mm (1"~6")	
Label length (cutter mode)	25.4~2286 mm (1"~90")	25.4~1016mm (1"~40")
Gap height	Min. 2 mm	
Black mark height	Min. 2 mm	
Black mark width	Min. 8 mm (0.31")	
Printout bias	Vertical: 1 mm max. Horizontal: 1 mm max.	
Environment condition	Operation: 5~40°C, 25~85% non-condensing Storage: -40~60°C, 10~90% non-condensing	
Safety regulation	FCC Class B, CE Class B, C-Tick Class B, UL, CUL, TÜV/GS, CCC	
Accessories	<ul style="list-style-type: none"> ■ BarTender UltraLite CD disk ■ Quick start guide ■ USB cable ■ External universal switching power supply ■ Power Cord ■ Label Spindle, fixing tab x2, 1.5" core adapter x2 ■ Ribbon spindle x2 ■ Ribbon rewind spindle paper core 	
Reliability	<ul style="list-style-type: none"> ■ TPH: 1 million inches or 12 months, which comes first since delivery from TSC (service part) ■ Platen: 50 km (service part) 	
Factory option	<ul style="list-style-type: none"> ■ Real time clock 	

Dealer option	<ul style="list-style-type: none"> ■ Peel off module assembly. ■ Guillotine cutter <p>Full cut: Paper thickness: 0.06~ 0.19mm, 500,000 cuts</p> <p>Partial cut: Paper thickness: 0.06~0.12mm, 500,000 cuts Paper thickness: 0.19mm 200,000 cuts</p> <ul style="list-style-type: none"> ■ Main board integrated with internal Ethernet ■ Internal Ethernet print server module
User option	<ul style="list-style-type: none"> ■ KP-200 ■ KU-007 plus ■ External Ethernet print server ■ External wireless (802.11b/g) print server ■ External roll mount, media OD. 214 mm (8.4") with 3" core label spindle ■ Contact CCD contact scanner ■ Long range linear image bar code scanner

1.2.2. Printer (TTP-247 / TTP-345)

Printer model	TTP-247	TTP-345
Item		
Resolution	203 DPI	300 DPI
Printing method	Thermal Transfer & Direct Thermal	
Print speed	2, 3, 4, 5, 6, 7 ips. 2, 3 ips for peeler mode	2, 3, 4, 5 ips 2 ips for peeler mode
Max. print width	108 mm (4.25")	106 mm (4.17")
Max. print length	2286 mm (90")	1016 mm (40")
Enclosure	Double-walled plastic	
Physical dimension	314mm (L) x 213mm (W) x 188mm (H)	
Ribbon capacity	300 meter, 1" core	
Label roll capacity	5" OD	

Processor	32-bit RISC high performance processor
Memory	<ul style="list-style-type: none"> ■ 4MB Flash memory ■ 8MB SDRAM ■ SD card reader for memory expansion
Interface	<ul style="list-style-type: none"> ■ RS-232 (max. 115200 bps) ■ Centronics ■ USB 2.0 (Full speed mode)
Power	<p>External universal switching power supply</p> <ul style="list-style-type: none"> ■ Input: AC 100-240V ■ Output: DC 24V 3.75A
Operation switch, button	<ul style="list-style-type: none"> ■ One power switch ■ One feed button ■ One LED (3 colors green, amber, red)
Sensors	<ul style="list-style-type: none"> ■ Gap transmissive sensor (offset 6 mm from liner edge) ■ Black mark reflective sensor (position adjustable) ■ Head open ■ Ribbon end sensor
Internal font	<ul style="list-style-type: none"> ■ 8 alpha-numeric bitmap fonts ■ One Monotype Imaging® CG Triumvirate Bold Condensed scalable font ■ Build-in Monotype True Type Font Engine

Code Page	<ul style="list-style-type: none"> ■ Codepage 437 (English - US) ■ Codepage 850 (Latin 1) ■ Codepage 852 (Latin 2) ■ Codepage 860 (Portuguese) ■ Codepage 863 (French Canadian) ■ Codepage 865 (Nordic) ■ Codepage 857 (Turkish) ■ Codepage 950 (Traditional Chinese) ■ Codepage 936 (Simplified Chinese) ■ Codepage 932 (Japanese) ■ Codepage 949 (Korean) ■ Codepage 1250 (Latin 2) ■ Codepage 1251 (Cyrillic) ■ Codepage 1252 (Latin 1) ■ Codepage 1253 (Greek) ■ Codepage 1254 (Turkish) ■ Codepage 1257 (Baltic) ■ Codepage 1258 (Vietnam) ■ ISO-8859-1: Latin-1 (Western European) ■ ISO-8859-2: Latin-2 (Central European) ■ ISO-8859-3: Latin-3 (South European) ■ ISO-8859-4: Latin-4 (North European) ■ ISO-8859-5: Cyrillic ■ ISO-8859-7: Greek ■ ISO-8859-9: Turkish ■ ISO-8859-10: Nordic ■ ISO-8859-15: Latin9
Bar code	<p>1D bar code Code 39, Code 93, Code128UCC, Code128 subsets A.B.C, Codabar, Interleave 2 of 5, EAN-8, EAN-13, EAN-128, UPC-A, UPC-E, EAN and UPC 2(5) digits add-on, MSI, PLESSEY, POSTNET, RSS-Stacked, RSS14, Code 11, China Post</p> <p>2D bar code PDF-417, Maxicode, DataMatrix, QR code, Aztec</p>
Font & barcode rotation	0, 90, 180,270 degrees
Command set	TSPL-EZ™

Media type	Continuous, die-cut, black mark, fan-fold, notch	
Media wound type	Outside wound	
Media width	20~112mm (0.78" ~ 4.4")	
Media thickness	0.06~0.19 mm (2.3~7.4 mil), max. 150g/m ²	
Media core diameter	25.4~76.2 mm (1"~3")	
Label length	Min. 10 mm (0.4")	
Label length (peeler mode)	25.4~152.4 mm (1"~6")	
Label length (cutter mode)	25.4~2286 mm (1"~90")	25.4~1016mm (1"~40")
Gap height	Min. 2 mm	
Black mark height	Min. 2 mm	
Black mark width	Min. 8 mm (0.31")	
Printout bias	Vertical: 1 mm max. Horizontal: 1 mm max.	
Environment condition	Operation: 5~40°C (41~140°F), 25~85% non-condensing Storage: -40~60°C (-40~140°F), 10~90% non-condensing	
Safety regulation	FCC Class B, CE Class B, C-Tick Class B, UL, CUL, TÜV/Safety, CCC	
Accessories	<ul style="list-style-type: none"> ■ Windows labeling software CD disk ■ Quick start guide ■ USB cable ■ External universal switching power supply ■ Power Cord ■ Label Spindle, fixing tab x2, 1.5" core adapter x2 ■ Ribbon spindle x2 ■ Ribbon rewind spindle paper core 	
Reliability	<ul style="list-style-type: none"> ■ TPH: 1 million inches or 12 months, which comes first since delivery from TSC (service part) ■ Platen: 50 km (service part) 	
Factory option	<ul style="list-style-type: none"> ■ Real time clock ■ Main board integrated with internal Ethernet 	

Dealer option	<ul style="list-style-type: none"> ■ Peel off module assembly. ■ Guillotine cutter <p>Full cut: Paper thickness: 0.06~ 0.19mm, 500,000 cuts</p> <p>Partial cut: Paper thickness: 0.06~0.12mm, 500,000 cuts</p> <p>Paper thickness: 0.19mm 200,000 cuts</p>
User option	<ul style="list-style-type: none"> ■ KP-200 Plus ■ KU-007 Plus ■ HCS-200 long range linear image bar code scanner ■ Bluetooth module

1.2.3. LED

LED Color	Description
Green/ Solid	This illuminates that the power is on and the device is ready to use.
Green/ Flash	This illuminates that the system is downloading data from PC to memory and the printer is paused.
Amber	This illuminates that the system is clearing data from printer.
Red / Solid	This illuminates printer head open, cutter error.
Red / Flash	This illuminates a printing error, such as paper empty, paper jam, ribbon empty, or memory error etc.

1.2.4. Button

<i>Feed</i>	<ul style="list-style-type: none"> ● Press the button when the LED is green. <ul style="list-style-type: none"> ■ It feeds the label to the beginning of the next label.
<i>Pause</i>	<ul style="list-style-type: none"> ● Press the feed button during printing <ul style="list-style-type: none"> ■ The printing job is suspended.

<p><i>Ribbon Sensor and Gap/Black Mark Sensor Calibration</i></p>	<ol style="list-style-type: none"> 1. Turn off the power switch. 2. Hold on the button then turn on the power switch. 3 Release the button when LED becomes red and blinking. (Any red will do during the 5 blinks). <ul style="list-style-type: none"> ■ It will calibrate the ribbon sensor and gap/black mark sensor sensitivity. ■ The LED color will be changed as following order : Amber → red (5 blinks) → amber (5 blinks) → green (5 blinks) → green/amber (5 blinks) → red/amber (5 blinks) → solid green <p>Note: Please select gap or black mark sensor by GAP or BLINE command prior to calibrate the sensor. For more information about GAP and BLINE command, please refer to TSPL2 programming manual.</p>
<p><i>Gap/Black Mark Sensor Calibration, Label Length Measurement, Self Test and enter Dump Mode</i></p>	<ol style="list-style-type: none"> 1. Turn off the power switch. 2. Hold on the button then turn on the power switch. 3. Release the button when LED becomes amber and blinking. (Any amber will do during the 5 blinks). <ul style="list-style-type: none"> ■ The LED color will be changed as following order. Amber → red (5 blinks) → amber (5 blinks) → green (5 blinks) → green/amber (5 blinks) → red/amber (5 blinks) → solid green ■ It calibrates the sensor and measures the label length and prints internal settings then enter the dump mode. <p>Note: Please select gap or black mark sensor by GAP or BLINE command prior to calibrate the sensor. For more information about GAP and BLINE command, please refer to TSPL2 programming manual.</p>

<p>Printer Initialization</p>	<ol style="list-style-type: none"> 1. Turn off the power switch. 2. Hold on the button then turn on the power switch. 3. Release the button when LED turns green after 5 amber blinks. (Any green will do during the 5 blinks). <ul style="list-style-type: none"> ■ The LED color will be changed as following: Amber → red (5 blinks) → amber (5 blinks) → green (5 blinks) → green/amber (5 blinks) → red/amber (5 blinks) → solid green <p>Note: Always do gap/black mark sensor calibration after printer initialization.</p>
<p>Force Black Mark Sensor Calibration</p>	<ol style="list-style-type: none"> 1. Turn off the power switch. 2. Hold on the button then turn on the power switch. 3. Release the button when LED turns green/amber after 5 green blinks. (Any green/amber will do during the 5 blinks). <ul style="list-style-type: none"> ■ The LED color will be changed as following: Amber → red (5 blinks) → amber (5 blinks) → green (5 blinks) → green/amber (5 blinks) → red/amber (5 blinks) → solid green
<p>Force Gap Sensor Calibration</p>	<ol style="list-style-type: none"> 1. Turn off the power switch. 2. Hold on the button then turn on the power switch. 3. Release the button when LED turns red/amber after 5 green/amber blinks. (Any red/amber will do during the 5 blinks). <ul style="list-style-type: none"> ■ The LED color will be changed as following: Amber → red (5 blinks) → amber (5 blinks) → green (5 blinks) → green/amber (5 blinks) → red/amber (5 blinks) → solid green

Skip AUTO.BAS

1. Turn off printer power.
2. Press the FEED button and then turn on power.
3. Release the FEED button when LED becomes **solid green**.
 - The LED color will be changed as following:
Amber → red (5 blinks) → amber (5 blinks) →
green (5 blinks) → green/amber (5 blinks) →
red/amber (5 blinks) → **solid green**
4. Printer will be interrupted to run the AUTO.BAS program.

1.3. Supply Specification

1.3.1. Paper

Item	Specification
Type	Label (Continuous , Die-cut , Fan-fold).
Wound Type	Outside wound.
Width	20~112mm (0.78" ~ 4.4")
Length (for peel and cutter)	10mm ~ 1000mm (0.4" ~ 39"). 25.4mm ~ 1000mm (1" ~ 39").
Thickness	0.06mm ~ 0.19mm.
Roll Diameter	5".
Roll Core Diameter	25.4mm ~ 76.2mm (1" ~ 3").
Gap Height	2mm min.
Black Mark Height	2mm min.
Black Mark Width	8mm min.

1.3.2. Ribbon

Item	Specification
Type	Wax, Wax / Resin, Resin.
Core Diameter	1".
Width	Max 110mm.
Capacity	300m with 1" core.
Wound Type	Outside wound.
Ribbon End	Clear or silver end tape.

2. ELECTRONICS







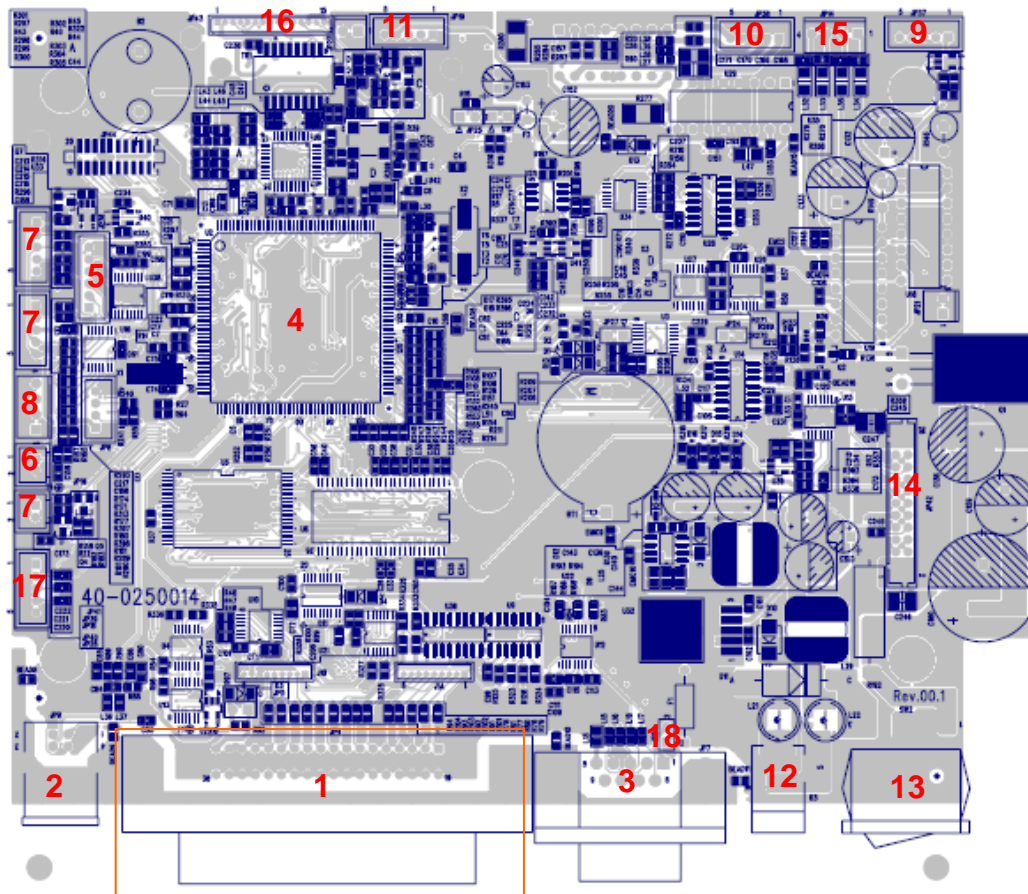



2.1 Summary of Board Connectors



Main board

Top



Connector	Description	Remark
1	Centronics port connector	JP4
2	USB connector	JP9
3	RS-232C connector	JP7
4	Micro processor	U2
5	RFID module connector	JP36

	Head open sensor connector	JP16																																								
6	 <table border="1" data-bbox="564 253 1155 521"> <thead> <tr> <th>Pin</th> <th>Description</th> <th>Voltage</th> </tr> </thead> <tbody> <tr> <td>1</td> <td>Head open sensor switch receiver</td> <td>0V: Head close 3.3V: Head open</td> </tr> <tr> <td>2</td> <td>GND</td> <td>0V</td> </tr> </tbody> </table>	Pin	Description	Voltage	1	Head open sensor switch receiver	0V: Head close 3.3V: Head open	2	GND	0V																																
Pin	Description	Voltage																																								
1	Head open sensor switch receiver	0V: Head close 3.3V: Head open																																								
2	GND	0V																																								
7	<table border="1" data-bbox="371 521 1155 1498"> <tr> <td data-bbox="371 521 727 1032"> JP39  </td> <td data-bbox="727 521 1155 1032"> <table border="1"> <thead> <tr> <th>Pin</th> <th>Description</th> <th>Voltage</th> </tr> </thead> <tbody> <tr> <td>1</td> <td>Reserved</td> <td></td> </tr> <tr> <td>2</td> <td>Gap sensor receiver AD</td> <td>0~3.3V</td> </tr> <tr> <td>3</td> <td>Power</td> <td>3.3V</td> </tr> <tr> <td>4</td> <td>Gap sensor emitter</td> <td>2.5~3.0V</td> </tr> <tr> <td>5</td> <td>Gap sensor power</td> <td>3.0~3.3V</td> </tr> </tbody> </table> </td> </tr> <tr> <td data-bbox="371 1032 727 1498"> JP41  </td> <td data-bbox="727 1032 1155 1498"> <table border="1"> <thead> <tr> <th>Pin</th> <th>Description</th> <th>Voltage</th> </tr> </thead> <tbody> <tr> <td>1</td> <td>Gap sensor power</td> <td>3.0~3.3V</td> </tr> <tr> <td>2</td> <td>Black mark sensor power</td> <td>3.0~3.3V</td> </tr> <tr> <td>3</td> <td>Black mark sensor emitter</td> <td>2.5~3.0V</td> </tr> <tr> <td>4</td> <td>Black mark sensor receiver AD</td> <td>0~3.3V</td> </tr> <tr> <td>5</td> <td>Power</td> <td>3.3V</td> </tr> </tbody> </table> </td> </tr> </table>	JP39 	<table border="1"> <thead> <tr> <th>Pin</th> <th>Description</th> <th>Voltage</th> </tr> </thead> <tbody> <tr> <td>1</td> <td>Reserved</td> <td></td> </tr> <tr> <td>2</td> <td>Gap sensor receiver AD</td> <td>0~3.3V</td> </tr> <tr> <td>3</td> <td>Power</td> <td>3.3V</td> </tr> <tr> <td>4</td> <td>Gap sensor emitter</td> <td>2.5~3.0V</td> </tr> <tr> <td>5</td> <td>Gap sensor power</td> <td>3.0~3.3V</td> </tr> </tbody> </table>	Pin	Description	Voltage	1	Reserved		2	Gap sensor receiver AD	0~3.3V	3	Power	3.3V	4	Gap sensor emitter	2.5~3.0V	5	Gap sensor power	3.0~3.3V	JP41 	<table border="1"> <thead> <tr> <th>Pin</th> <th>Description</th> <th>Voltage</th> </tr> </thead> <tbody> <tr> <td>1</td> <td>Gap sensor power</td> <td>3.0~3.3V</td> </tr> <tr> <td>2</td> <td>Black mark sensor power</td> <td>3.0~3.3V</td> </tr> <tr> <td>3</td> <td>Black mark sensor emitter</td> <td>2.5~3.0V</td> </tr> <tr> <td>4</td> <td>Black mark sensor receiver AD</td> <td>0~3.3V</td> </tr> <tr> <td>5</td> <td>Power</td> <td>3.3V</td> </tr> </tbody> </table>	Pin	Description	Voltage	1	Gap sensor power	3.0~3.3V	2	Black mark sensor power	3.0~3.3V	3	Black mark sensor emitter	2.5~3.0V	4	Black mark sensor receiver AD	0~3.3V	5	Power	3.3V	JP39, JP41
JP39 	<table border="1"> <thead> <tr> <th>Pin</th> <th>Description</th> <th>Voltage</th> </tr> </thead> <tbody> <tr> <td>1</td> <td>Reserved</td> <td></td> </tr> <tr> <td>2</td> <td>Gap sensor receiver AD</td> <td>0~3.3V</td> </tr> <tr> <td>3</td> <td>Power</td> <td>3.3V</td> </tr> <tr> <td>4</td> <td>Gap sensor emitter</td> <td>2.5~3.0V</td> </tr> <tr> <td>5</td> <td>Gap sensor power</td> <td>3.0~3.3V</td> </tr> </tbody> </table>	Pin	Description	Voltage	1	Reserved		2	Gap sensor receiver AD	0~3.3V	3	Power	3.3V	4	Gap sensor emitter	2.5~3.0V	5	Gap sensor power	3.0~3.3V																							
Pin	Description	Voltage																																								
1	Reserved																																									
2	Gap sensor receiver AD	0~3.3V																																								
3	Power	3.3V																																								
4	Gap sensor emitter	2.5~3.0V																																								
5	Gap sensor power	3.0~3.3V																																								
JP41 	<table border="1"> <thead> <tr> <th>Pin</th> <th>Description</th> <th>Voltage</th> </tr> </thead> <tbody> <tr> <td>1</td> <td>Gap sensor power</td> <td>3.0~3.3V</td> </tr> <tr> <td>2</td> <td>Black mark sensor power</td> <td>3.0~3.3V</td> </tr> <tr> <td>3</td> <td>Black mark sensor emitter</td> <td>2.5~3.0V</td> </tr> <tr> <td>4</td> <td>Black mark sensor receiver AD</td> <td>0~3.3V</td> </tr> <tr> <td>5</td> <td>Power</td> <td>3.3V</td> </tr> </tbody> </table>	Pin	Description	Voltage	1	Gap sensor power	3.0~3.3V	2	Black mark sensor power	3.0~3.3V	3	Black mark sensor emitter	2.5~3.0V	4	Black mark sensor receiver AD	0~3.3V	5	Power	3.3V																							
Pin	Description	Voltage																																								
1	Gap sensor power	3.0~3.3V																																								
2	Black mark sensor power	3.0~3.3V																																								
3	Black mark sensor emitter	2.5~3.0V																																								
4	Black mark sensor receiver AD	0~3.3V																																								
5	Power	3.3V																																								
8	<table border="1" data-bbox="371 1498 1155 1989"> <tr> <td data-bbox="371 1498 639 1989">  </td> <td data-bbox="639 1498 1155 1989"> <table border="1"> <thead> <tr> <th>Pin</th> <th>Description</th> <th>Voltage</th> </tr> </thead> <tbody> <tr> <td>1</td> <td>Ribbon sensor emitter</td> <td>On: 3.7~3.9V Off: 4.3~4.6V</td> </tr> <tr> <td>2</td> <td>Power</td> <td>5V</td> </tr> <tr> <td>3</td> <td>Ribbon sensor receiver</td> <td>No ribbon: 0V With ribbon: 3.3V</td> </tr> <tr> <td>4</td> <td>GND</td> <td>0V</td> </tr> </tbody> </table> </td> </tr> </table>		<table border="1"> <thead> <tr> <th>Pin</th> <th>Description</th> <th>Voltage</th> </tr> </thead> <tbody> <tr> <td>1</td> <td>Ribbon sensor emitter</td> <td>On: 3.7~3.9V Off: 4.3~4.6V</td> </tr> <tr> <td>2</td> <td>Power</td> <td>5V</td> </tr> <tr> <td>3</td> <td>Ribbon sensor receiver</td> <td>No ribbon: 0V With ribbon: 3.3V</td> </tr> <tr> <td>4</td> <td>GND</td> <td>0V</td> </tr> </tbody> </table>	Pin	Description	Voltage	1	Ribbon sensor emitter	On: 3.7~3.9V Off: 4.3~4.6V	2	Power	5V	3	Ribbon sensor receiver	No ribbon: 0V With ribbon: 3.3V	4	GND	0V	JP18																							
	<table border="1"> <thead> <tr> <th>Pin</th> <th>Description</th> <th>Voltage</th> </tr> </thead> <tbody> <tr> <td>1</td> <td>Ribbon sensor emitter</td> <td>On: 3.7~3.9V Off: 4.3~4.6V</td> </tr> <tr> <td>2</td> <td>Power</td> <td>5V</td> </tr> <tr> <td>3</td> <td>Ribbon sensor receiver</td> <td>No ribbon: 0V With ribbon: 3.3V</td> </tr> <tr> <td>4</td> <td>GND</td> <td>0V</td> </tr> </tbody> </table>	Pin	Description	Voltage	1	Ribbon sensor emitter	On: 3.7~3.9V Off: 4.3~4.6V	2	Power	5V	3	Ribbon sensor receiver	No ribbon: 0V With ribbon: 3.3V	4	GND	0V																										
Pin	Description	Voltage																																								
1	Ribbon sensor emitter	On: 3.7~3.9V Off: 4.3~4.6V																																								
2	Power	5V																																								
3	Ribbon sensor receiver	No ribbon: 0V With ribbon: 3.3V																																								
4	GND	0V																																								

	Ribbon encoder sensor connector	JP37																		
9		<table border="1"> <thead> <tr> <th>Pin</th> <th>Description</th> <th>Voltage</th> </tr> </thead> <tbody> <tr> <td>1</td> <td>Power</td> <td>5V</td> </tr> <tr> <td>2</td> <td>Ribbon encoder sensor receiver</td> <td>High: 5V (reflecting) Low: 0V (non-reflecting)</td> </tr> <tr> <td>3</td> <td>GND</td> <td>0V</td> </tr> <tr> <td>4</td> <td>DC motor</td> <td>Work: <23V No work: 23.4V~24V</td> </tr> <tr> <td>5</td> <td>DC motor</td> <td>23.4V~24V</td> </tr> </tbody> </table>	Pin	Description	Voltage	1	Power	5V	2	Ribbon encoder sensor receiver	High: 5V (reflecting) Low: 0V (non-reflecting)	3	GND	0V	4	DC motor	Work: <23V No work: 23.4V~24V	5	DC motor	23.4V~24V
		Pin	Description	Voltage																
		1	Power	5V																
		2	Ribbon encoder sensor receiver	High: 5V (reflecting) Low: 0V (non-reflecting)																
		3	GND	0V																
		4	DC motor	Work: <23V No work: 23.4V~24V																
5	DC motor	23.4V~24V																		
10	Cutter connector	JP38																		
11		<table border="1"> <thead> <tr> <th>Pin</th> <th>Description</th> <th>Voltage</th> </tr> </thead> <tbody> <tr> <td>1</td> <td>GND</td> <td>0V</td> </tr> <tr> <td>2</td> <td>Peel sensor receiver AD</td> <td>0~3.3V</td> </tr> <tr> <td>3</td> <td>Peel sensor emitter</td> <td>Emitter on: 1.0~1.2V Emitter off: 0V</td> </tr> <tr> <td>4</td> <td>Power</td> <td>5V</td> </tr> <tr> <td>5</td> <td>Reserved</td> <td></td> </tr> </tbody> </table>	Pin	Description	Voltage	1	GND	0V	2	Peel sensor receiver AD	0~3.3V	3	Peel sensor emitter	Emitter on: 1.0~1.2V Emitter off: 0V	4	Power	5V	5	Reserved	
		Pin	Description	Voltage																
		1	GND	0V																
		2	Peel sensor receiver AD	0~3.3V																
		3	Peel sensor emitter	Emitter on: 1.0~1.2V Emitter off: 0V																
		4	Power	5V																
5	Reserved																			
12	Power supply output (24V DC) connector	B3																		
13	Power switch	SW2																		
14	Print head connector	JP42																		
15	Stepping motor connector	JP14																		
16	Ethernet connector (Factory option)	JP43																		
17		<table border="1"> <thead> <tr> <th>Pin</th> <th>Description</th> <th>Voltage</th> </tr> </thead> <tbody> <tr> <td>1</td> <td>Power</td> <td>3.3V</td> </tr> <tr> <td>2</td> <td>LED green</td> <td>LED light on: 1.1~1.4V LED light off: 1.6~1.9V</td> </tr> <tr> <td>3</td> <td>LED red</td> <td>LED light on: 1.4~1.7V LED light off: 1.8~2.1V</td> </tr> <tr> <td>4</td> <td>Feed switch</td> <td>0V: Push key 3.3V: Stand-by</td> </tr> <tr> <td>5</td> <td>GND</td> <td>0V</td> </tr> </tbody> </table>	Pin	Description	Voltage	1	Power	3.3V	2	LED green	LED light on: 1.1~1.4V LED light off: 1.6~1.9V	3	LED red	LED light on: 1.4~1.7V LED light off: 1.8~2.1V	4	Feed switch	0V: Push key 3.3V: Stand-by	5	GND	0V
		Pin	Description	Voltage																
		1	Power	3.3V																
		2	LED green	LED light on: 1.1~1.4V LED light off: 1.6~1.9V																
		3	LED red	LED light on: 1.4~1.7V LED light off: 1.8~2.1V																
		4	Feed switch	0V: Push key 3.3V: Stand-by																
5	GND	0V																		
18	RS-232 pin 9 +5V jumper	JP6																		

Main board

Bottom

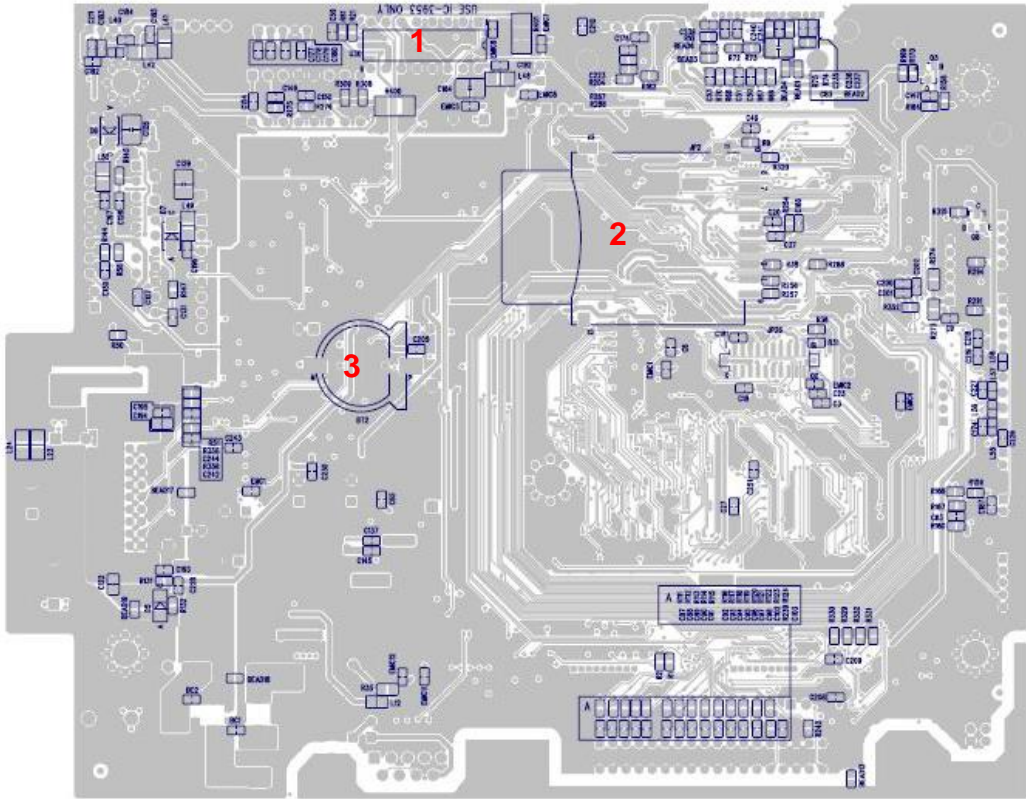

Connector	Description	Remark
1	Cutter driver IC connector	U30
2	SD card slot	JP2
3	RTC battery (Factory option)	BT2

2.2 Pin Configuration

RS-232C

PIN	CONFIGURATION
1	+5 V
2	TXD
3	RXD
4	CTS
5	GND
6	RTS
7	N/C
8	RTS
9	N/C

USB

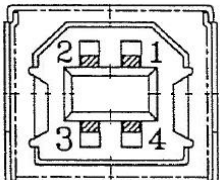
	PIN	CONFIGURATION
	1	N/C
	2	D-
	3	D+
	4	GND

Centronics

Pin	SPP Mode	Nibble	In/Out	Function
1	Strobe	N/A	In	A low on this line indicates that there are valid data at the host. When this pin is de-asserted, the +ve clock edge should be used to shift the data into the device.
2-9	Data 0-7	N/A	In	Data Bus. Single-directional.
10	Ack	N/A	Out	A low on this line indicates that there are valid data at the Device. When this pin is de-asserted, the +ve clock edge should be used to shift the data into the host.
11	Busy	N/A	Out	When in reverse direction, a high indicates data, while a low indicates a command cycle. In forward direction, it functions as PtrBusy.

12	Paper Out / End	N/A	Out	When low , device acknowledges reverse request.
13	Select	N/A	Out	Extensibility flag
14	Ground	N/A	GND	
15	No Defined	N/A	N/A	
16-17	Ground	N/A	GND	Ground
18	No Defined	N/A	N/A	
19-30	Ground	N/A	GND	Ground
31	No Defined	N/A	N/A	
32	Error / Fault	N/A	Out	A low set by the device indicates that the reverse data is available
33-35	Ground	N/A	GND	Ground
36	No Defined	N/A	N/A	

Ethernet

PIN	CONFIGURATION
1	Tx+
2	Tx-
3	Rx+
4	N/C
5	N/C
6	Rx-
7	N/C
8	N/C

3. REPLACE IMPORTANT PARTS

Please turn off the power switch and unplug the power adapter before replacing parts.

3.1. Replacing Top Cover

1. Open the printer **top cover** by pushing the **top cover open levers** to the **paper outlet direction**. The **top cover support** will hold the printer **top cover**.



2. Open the top cover to the ultimate open angle. Push the top cover support to the communication port direction to disconnect the separate the lower inner cover and top cover support.



3. Remove the 6 screws in the **top inner cover**.

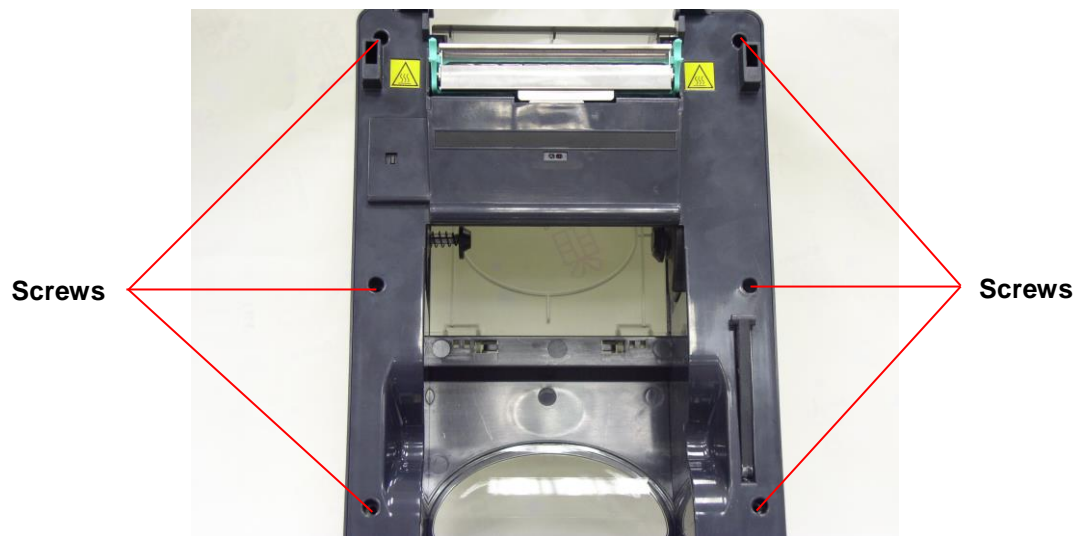

4. Disconnect the harness from the Feed button PCB. Replace the top cover.
5. Reassemble parts in reverse procedures.

3.2. Replacing Top Inner Cover

1. Refer 3.1 to remove the top cover.
2. Remove the 6 screws of lower inner cover. Turn the printer upside down, and remove the 2 screws of hinge holder, 1 screw of memory card cover.

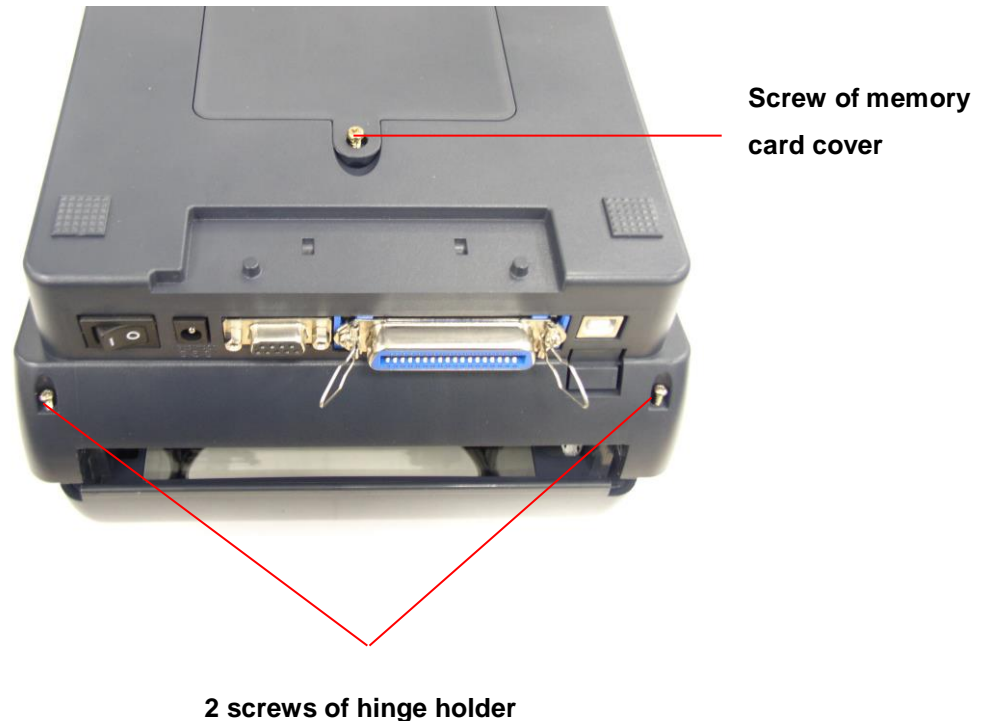
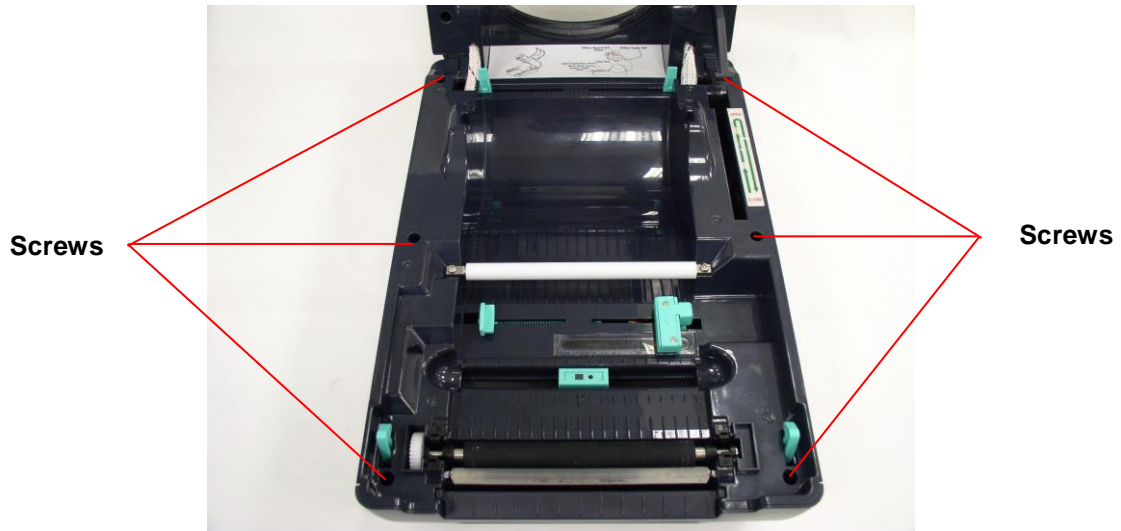

3. Disconnect all the harnesses from Main Board. Lift up the lower inner cover. Turn the lower inner cover upside down, and remove the 6 screws of lower inner cover and hinge holders.

4. Replace the top inner cover.
5. Reassemble in reverse procedures.

3.3. Replacing Lower Cover

1. Refer to 3.1 to open the top cover.
2. Remove the 6 screws of lower inner cover. Turn the printer upside down, and remove the 2 screws of hinge holder, 1 screw of memory card cover.

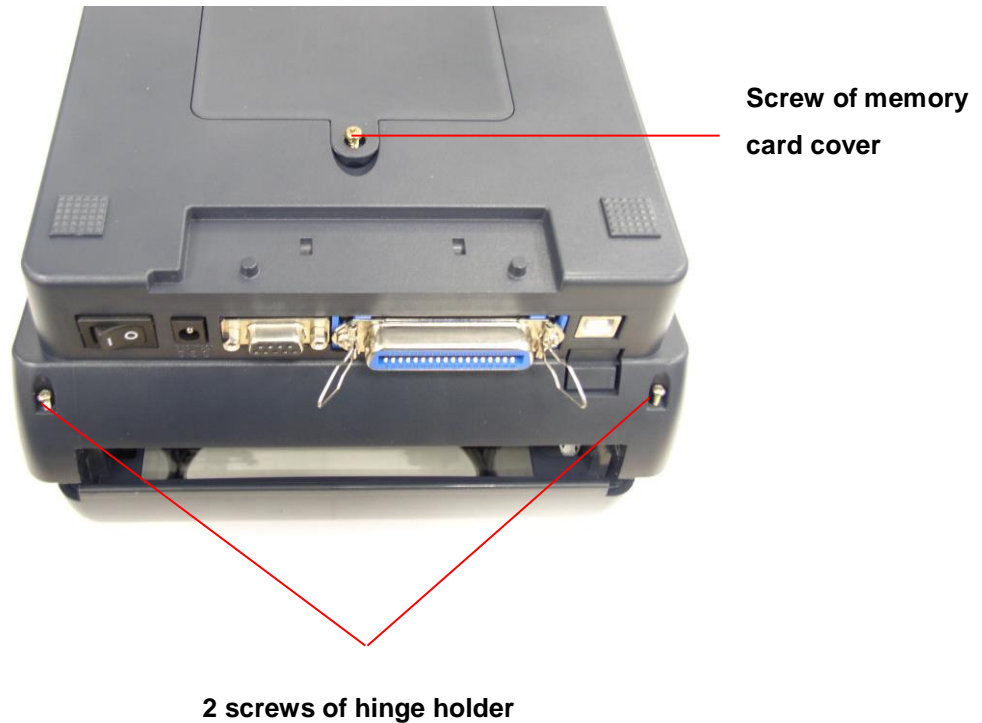
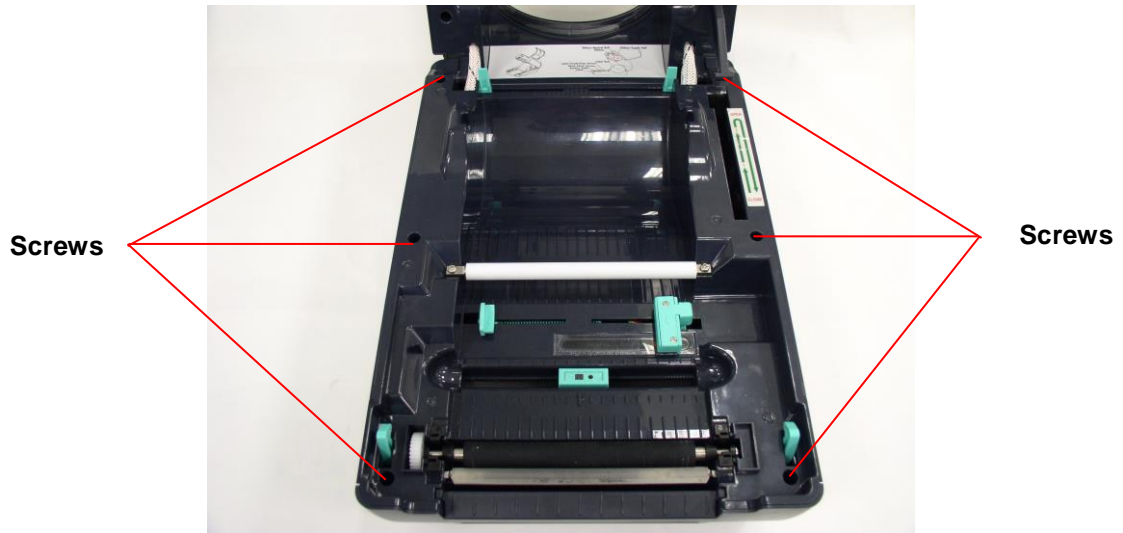

3. Disconnect all the harnesses from Main Board. Lift up the lower inner cover.
4. Replace lower cover.
5. Reassemble in reverse procedures.

3.4. Replacing Main Board

1. Please refer to 3.3 for disassembling the LOWER COVER and LOWER inner cover.
2. Disconnect all harnesses.
3. Remove 4 screws on the **main board**.



4. Replace the main board/lower inner cover.
5. Reassemble parts in reverse procedures.

3.5. Replacing Platen Assembly

1. Squeeze two sides of **platen assembly** and take it out.

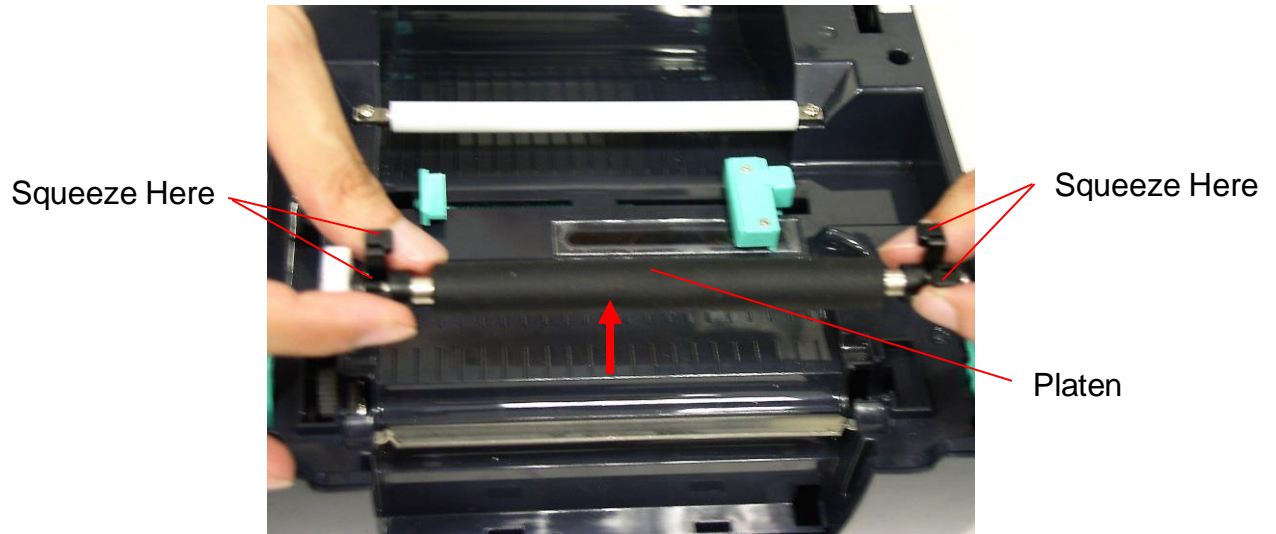

2. Replace a platen.
3. Reassemble it in reverse procedures.

3.6. Replacing the Stepping Motor Bracket / Metal Assembly and Stepping Motor

1. Please refer to 3.1 for disassembling the lower cover and lower inner cover.
2. Disconnect all hardness.
3. Turn the lower inner cover upside down.
4. Remove 2 screws that fixed the stepping motor on the bracket
5. Remove the stepping motor.

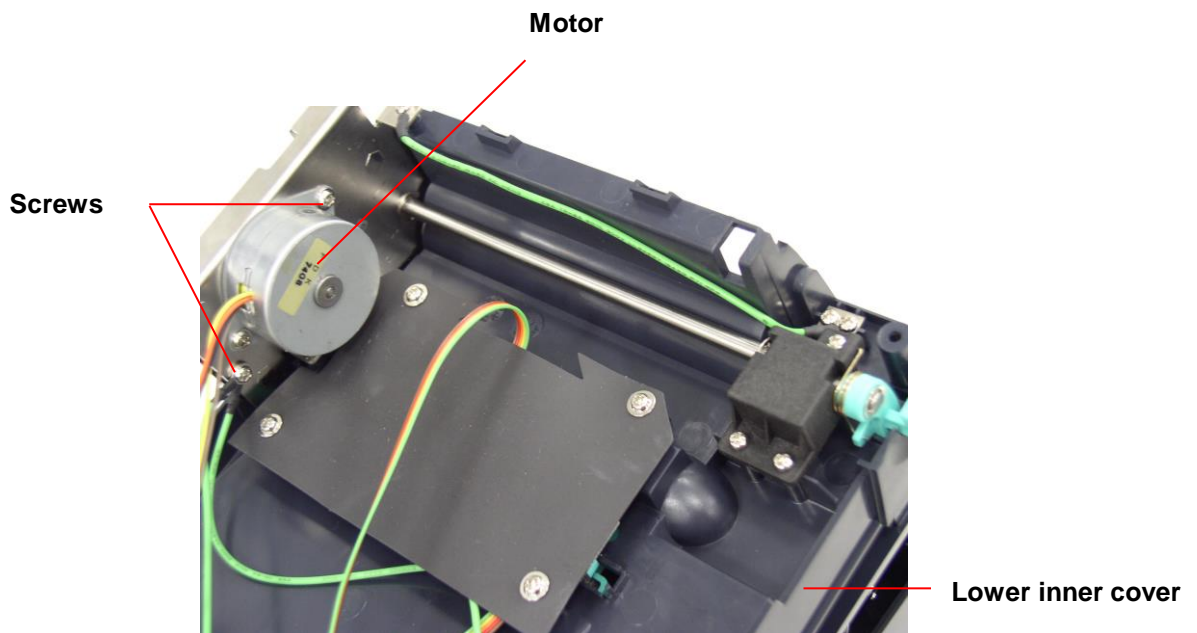

6. Use a screwdriver to screw off 8 screws of the **stepping motor bracket / metal ass'y.**

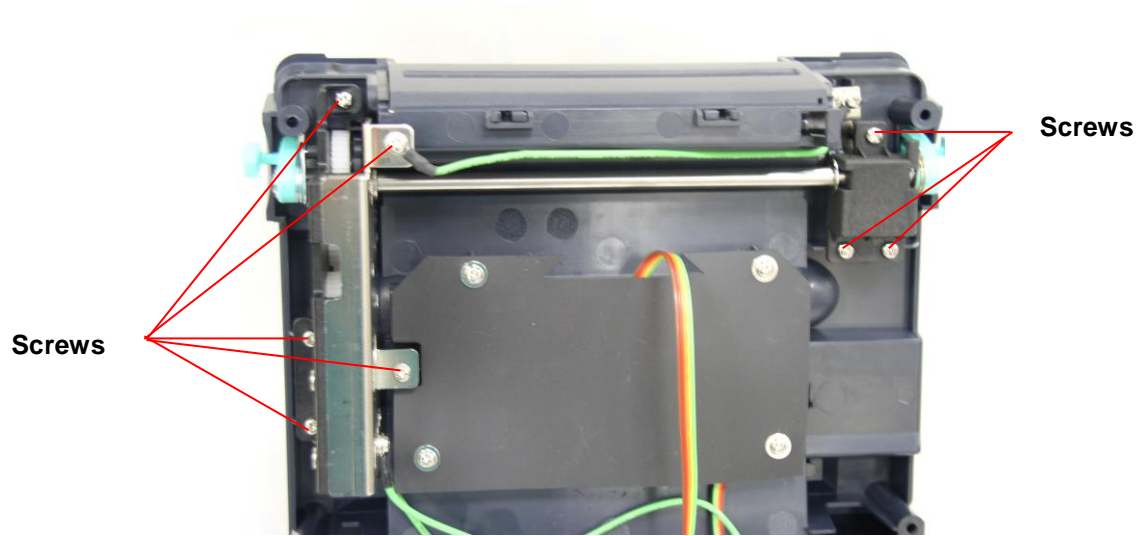

7. Remove the **stepping motor bracket / metal ass'y.**

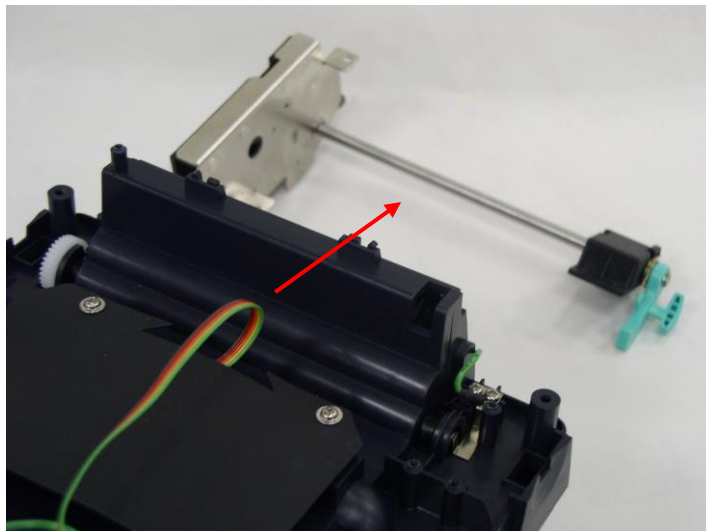

8. Reassemble parts in reverse procedures.

3.7. Replacing Label Guide & Gap Sensor Assembly

1. Please refer to 3.1 for disassembling the lower cover and lower inner cover.
2. Disconnect all the hardness.
3. Turn the lower inner cover upside down.
4. Screws off 4 screws and remove the **plastic laminate**.

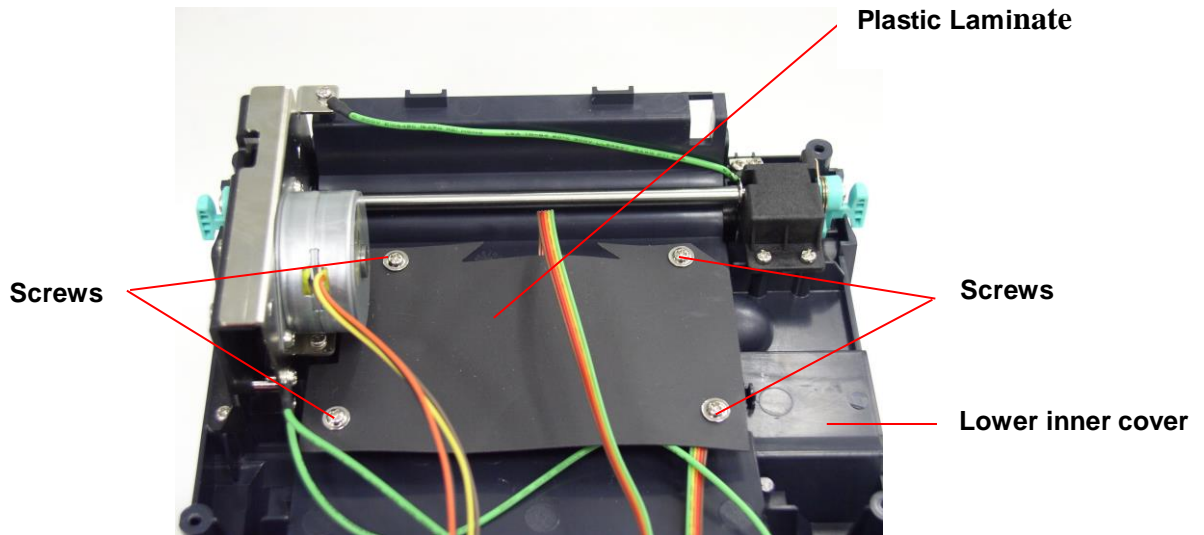

5. Screws off 2 screws to remove the white **label guide rack fixing plate**
6. Remove 2 screws from a gap sensor PCB then remove the **gap sensor PCB**.

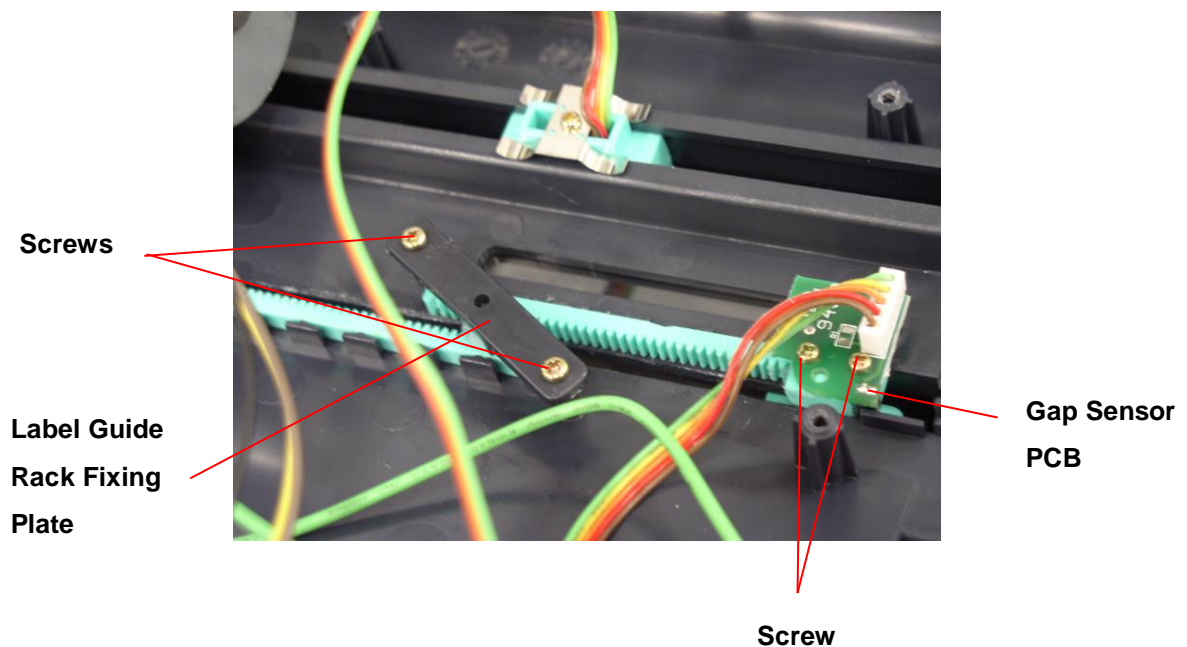

7. Turn over the lower inner cover.
8. Move **right side and left side label guides** to the end of each side. Rotates 90 degrees and pull them out.

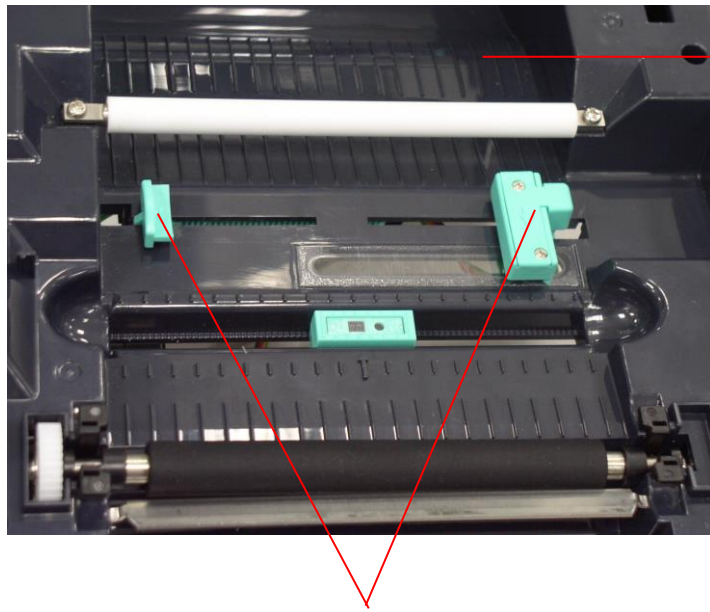

Lower inner cover

Label Guide

9. Reassemble parts in reverse procedures.

3.8. Replacing Black Mark Sensor Assembly

1. Please refer to 3.1 for disassembling the lower cover and lower inner cover.
2. Disconnect all hardness.
3. Upside down the lower inner cover. Remove 4 screws and remove the **plastic laminate**.
4. Remove 1 screw from the **black mark sensor**.

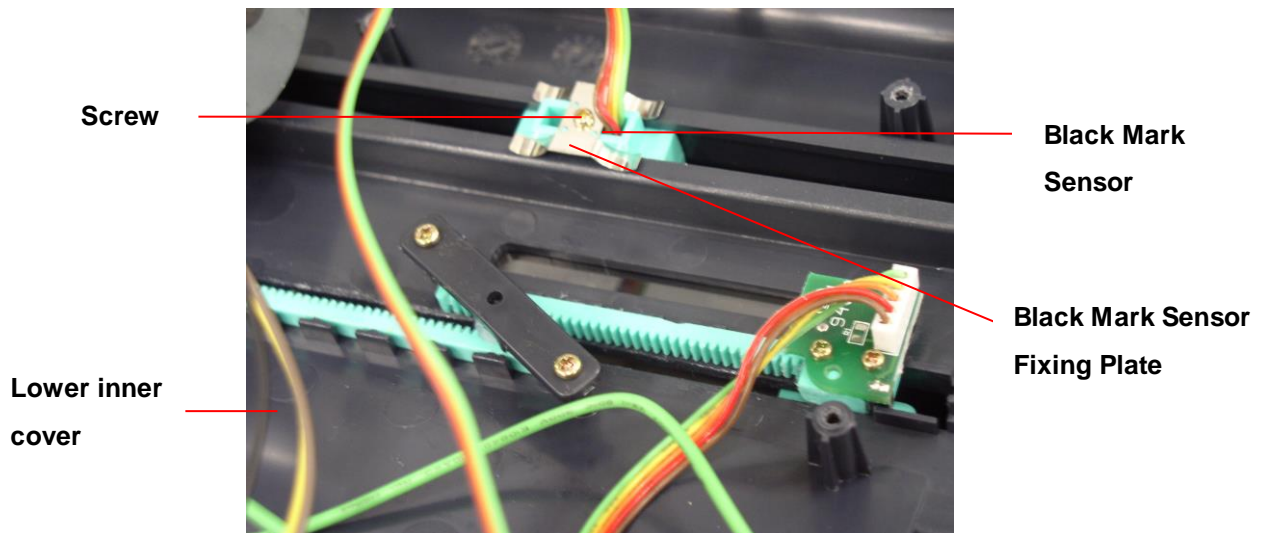

5. Upside down the lower inner cover.
6. Replace the **black mark sensor** assembly.

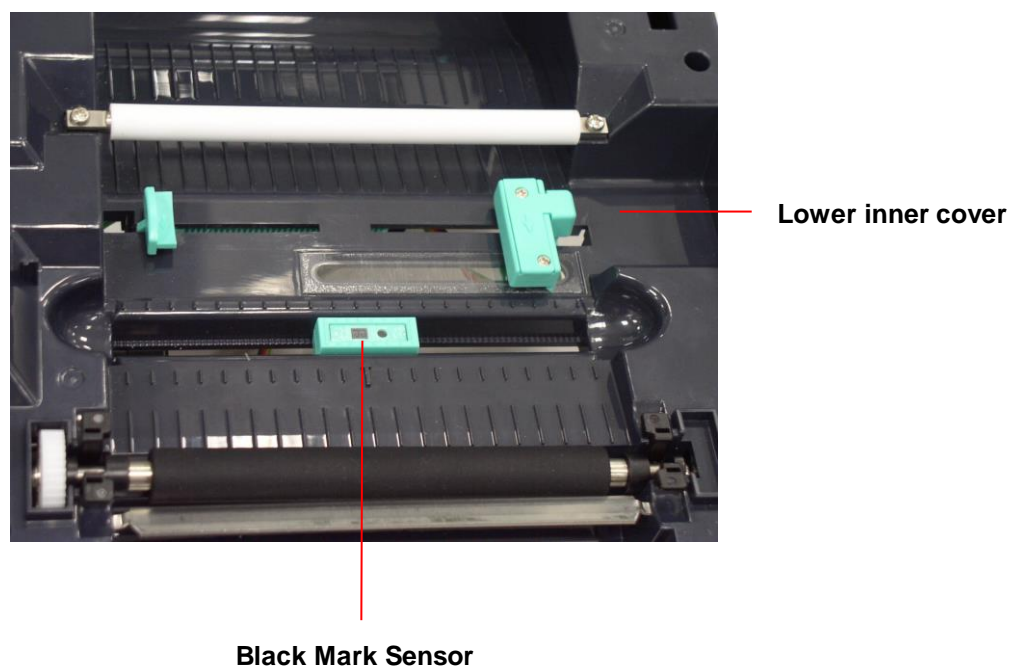

7. Reassemble parts in reverse procedures.

3.9. Replacing Print Head Assembly

1. Press right concave of the print head **bracket** and use a flat screwdriver to stick left side of the printer head bracket then pick up the print head assembly.
2. Disconnect print head harnesses.
3. Reassemble parts in reverse procedures.

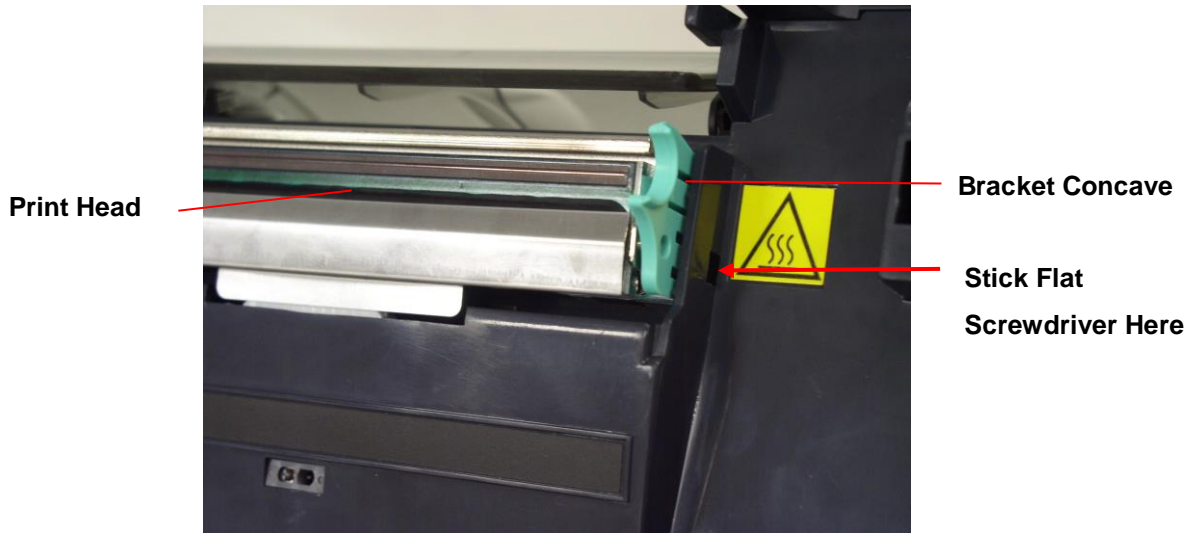

3.10. Replacing Head Open Micro Switch

1. Please refer to 3.1 for disassembling the top cover and top inner cover.
2. Disconnect **ribbon mechanism** by removing 4 screws at top inner cover.

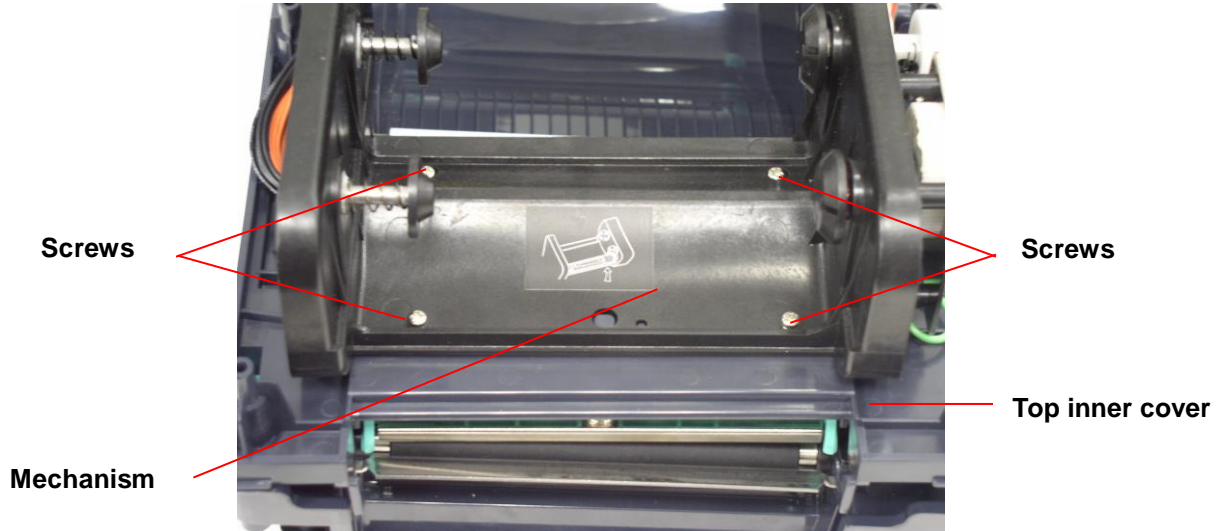

3. Remove 2 screws and remove the **head open micro switch**.

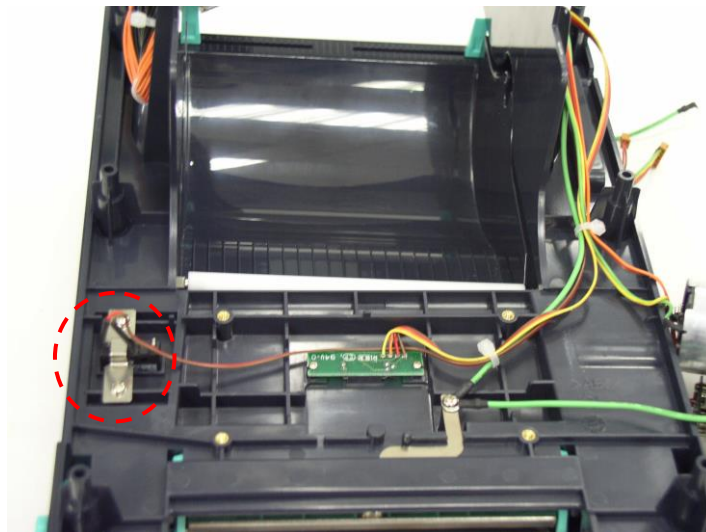

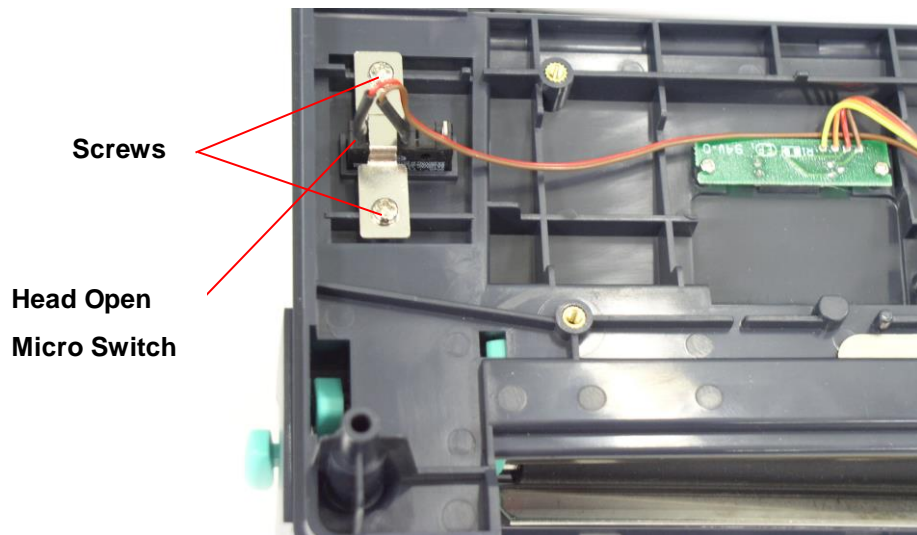

4. Reassemble parts in reverse procedures.

3.11. Replacing Ribbon Motor and Ribbon Sensor

1. Please refer to 3.1 for disassembling the top cover and top inner cover.
2. Disconnect **ribbon mechanism** by removing 4 screws from the top inner cover.
3. Remove 2 screws on the ribbon motor PCB.
4. Replace the **ribbon motor sensor**.

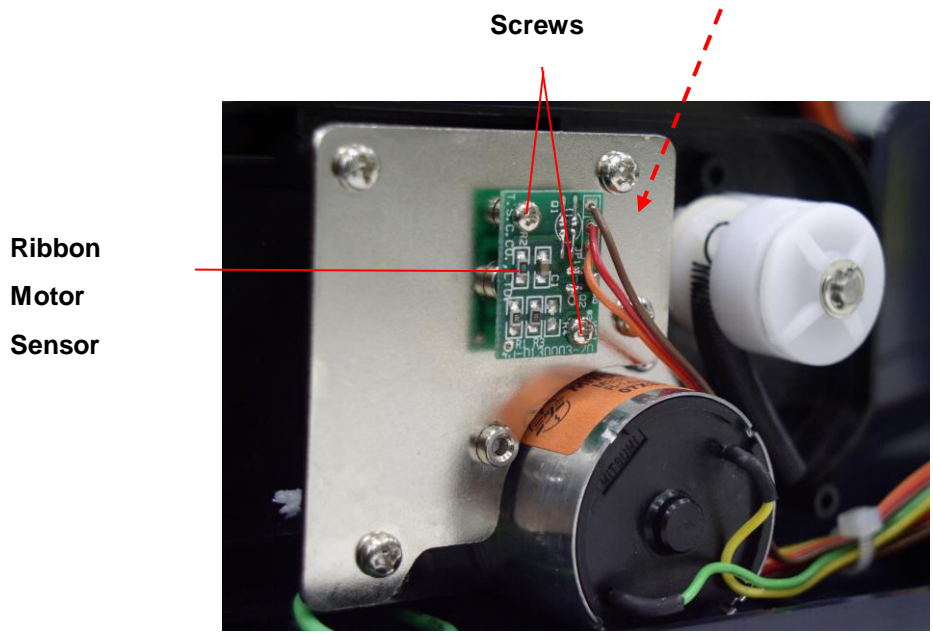
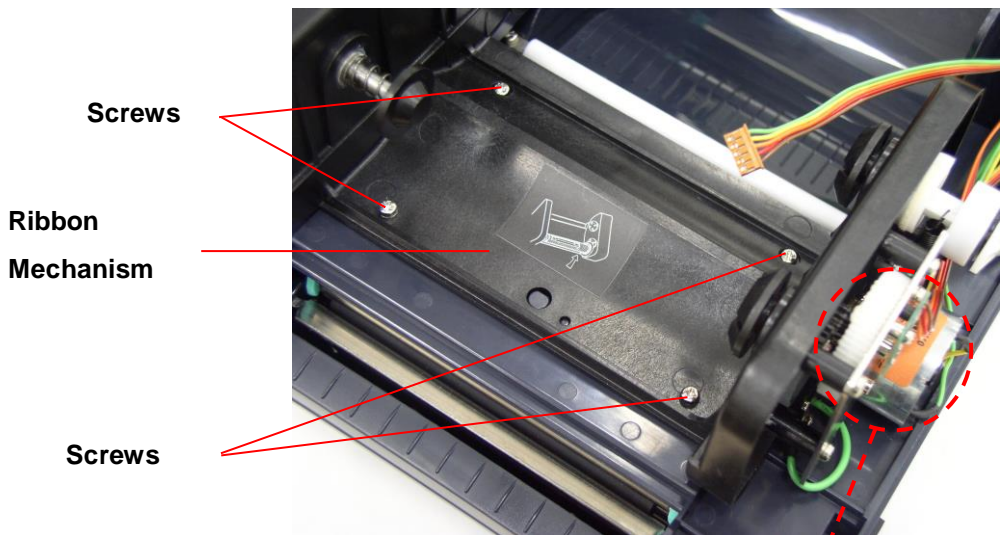

5. Screw off 2 screws from the top inner cover.
6. Replace the **ribbon sensor**.
7. Reassemble parts in reverse procedures.

Top inner cover

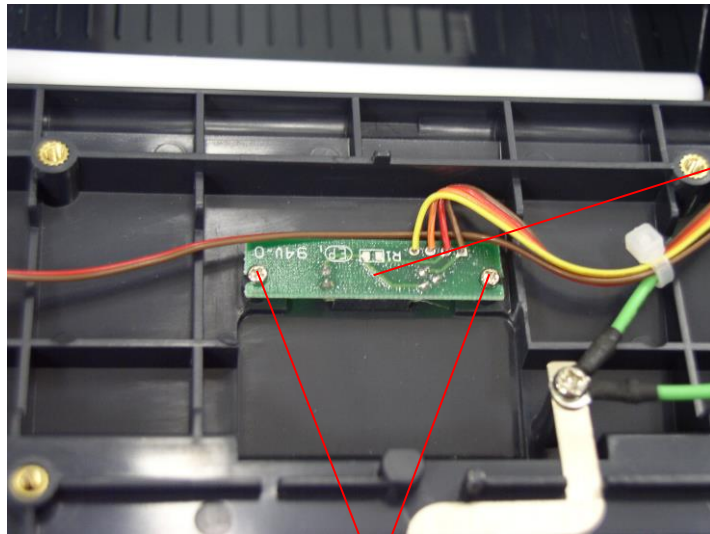
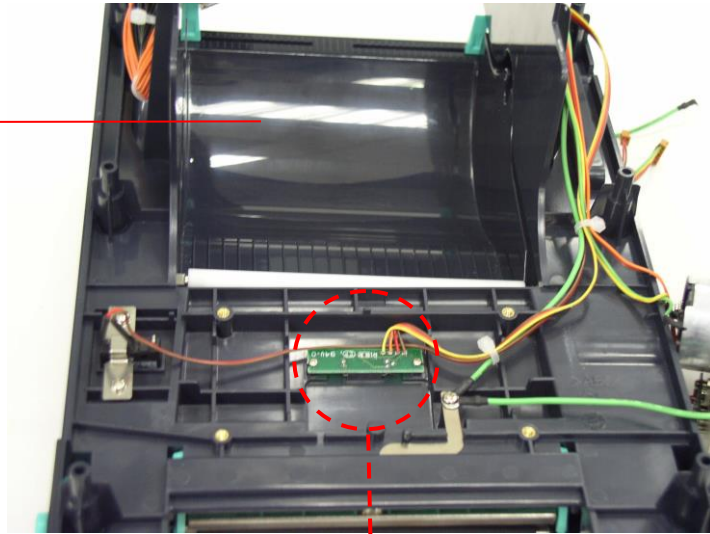

Ribbon Sensor

Screws

3.12. Replacing Feed Button and Feed Button PCB

1. Please refer to 3.1 for disassembling the top cover and top inner cover.
2. Turn the top cover upside down.
3. Screw off 2 screws on **feed button PCB** and remove feed button PCB.
4. Use a flat head driver to poke up the **feed button**.

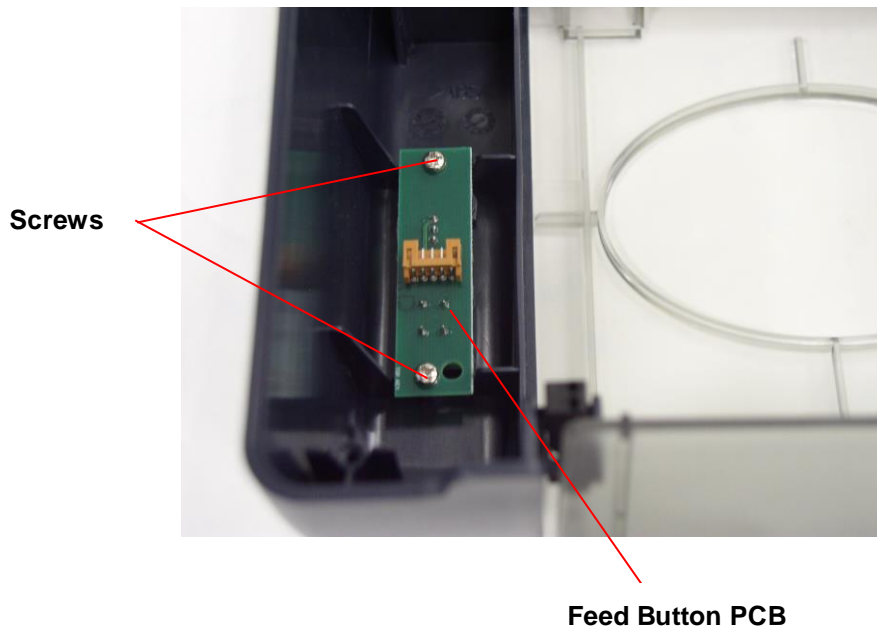
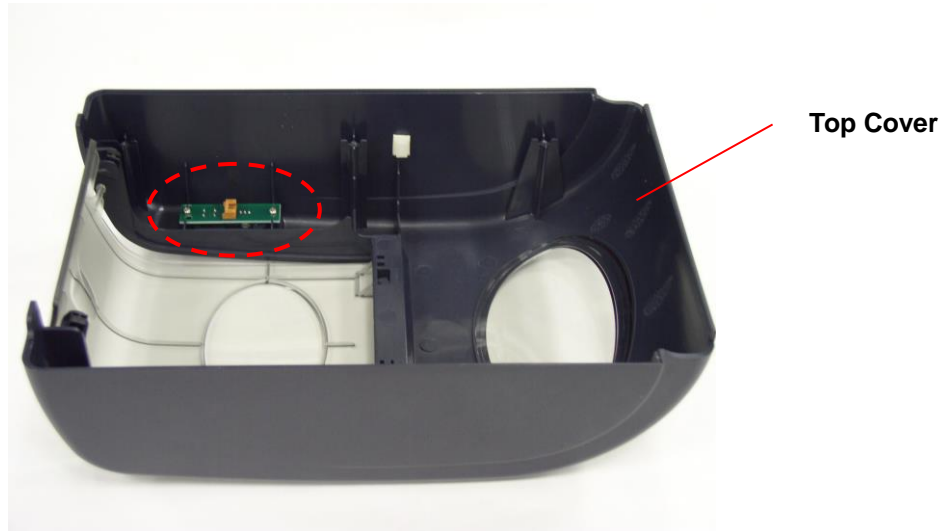

5. Reassemble parts in reverse procedures.

3.13. Install SD Memory Card

1. Turn the printer upside down.
2. Remove the screw that fixes the **memory card cover**.

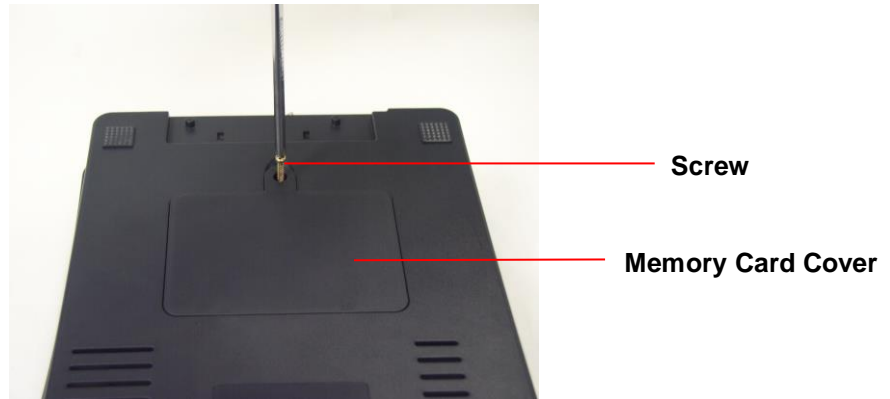

3. Plug in a SD card on main board.

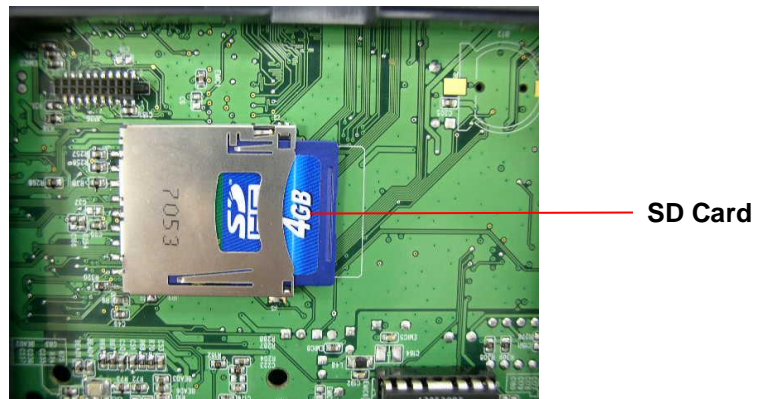

4. Revert the memory card cover.
5. Reassemble parts in reverse procedures.

* Recommended SD card specification.

SD card spec	SD card capacity	Approved SD card manufacturer
V1.0, V1.1	128 MB	SanDisk, Transcend
V1.0, V1.1	256 MB	SanDisk, Transcend, Panasonic
V1.0, V1.1	512 MB	SanDisk, Transcend, Panasonic
V1.0, V1.1	1 GB	SanDisk, Transcend, Panasonic
V2.0 SDHC CLASS 4	4 GB	
V2.0 SDHC CLASS 6	4 GB	SanDisk, Transcend, Panasonic
V1.0, V1.1	microSD 128 MB	Transcend, Panasonic
V1.0, V1.1	microSD 256 MB	Transcend, Panasonic
V1.0, V1.1	microSD 512 MB	Panasonic
V1.0, V1.1	microSD 1 GB	Transcend, Panasonic

V2.0 SDHC CLASS 4	microSD 4 GB	Panasonic
V2.0 SDHC CLASS 6	microSD 4 GB	Transcend
V1.0, V1.1	miniSD 128 MB	Transcend, Panasonic
V1.0, V1.1	miniSD 256 MB	Transcend, Panasonic
V1.0, V1.1	miniSD 512 MB	Transcend, Panasonic
V1.0, V1.1	miniSD 1 GB	Transcend, Panasonic
V2.0 SDHC CLASS 4	miniSD 4 GB	Transcend
V2.0 SDHC CLASS 6	miniSD 4 GB	
<ul style="list-style-type: none"> - The DOS FAT file system is supported for the SD card. - Folders/files stored in the SD card should be in the 8.3 filename format - The miniSD/microSD card to SD card slot adapter is required. 		

3.14. Install Peel off Module (Option)

1. Open the top cover.
2. Remove two screws for hinge support and one screw for memory card cover in lower cover.
3. Remove 6 screws on the lower inner cover.
4. Hold the lower cover and lift up the top cover open levers to separate the lower inner cover and the lower cover. (Please refer to section 3.1)
5. Connect the harness of peel-off module through the slot of lower inner cover.

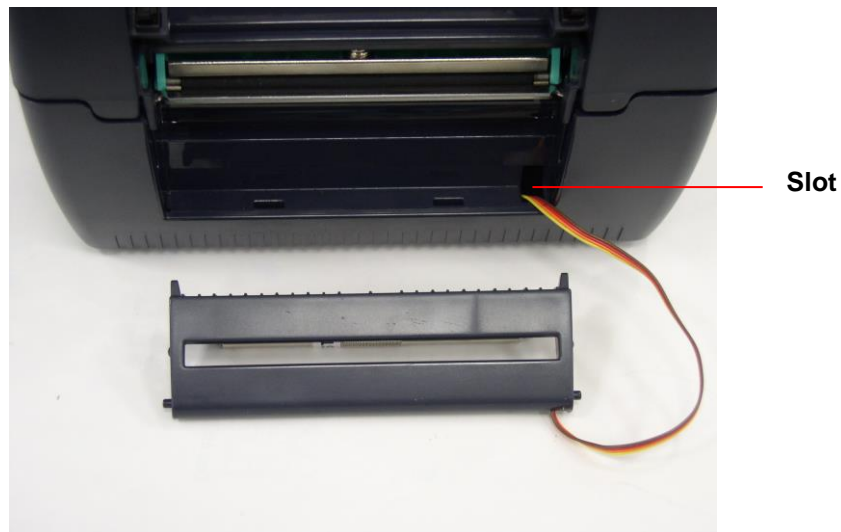

6. Lift up the lower inner cover to gently push peel off panel into the two concaves of lower cover front side.

Note: Must lift up the lower inner cover first, then, the peel-off module could be installed into the concave of lower inner cover.

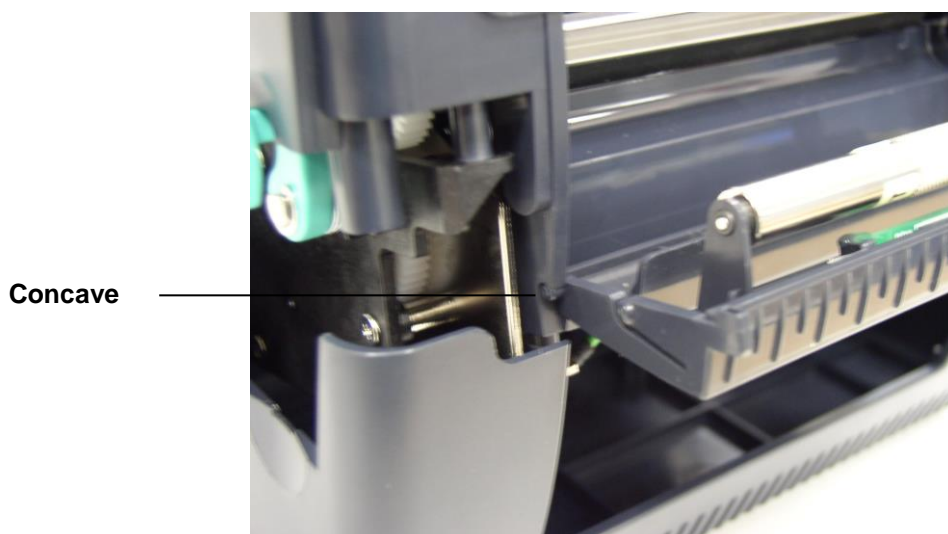

7. Connect the harness of peel-off module at JP19 on the main board.
8. Put down the lower inner cover onto lower cover.



9. Push peel off module to lock to the lower inner cover.



10. Reassemble parts in reverse procedures.

3.15. Loading the Label in Peel-off Mode

Note: Both thermal paper and plain paper apply for peel-off function but neither PVC nor vnyle work at peel-off function.

1. Insert a 1” label spindle into a paper roll.
2. Open the printer top cover by pushing forward the top cover open levers. The top cover support will hold the printer top cover.



3. Install the paper roll on the paper roll mount.
4. Open the peel-off panel by pulling it out.

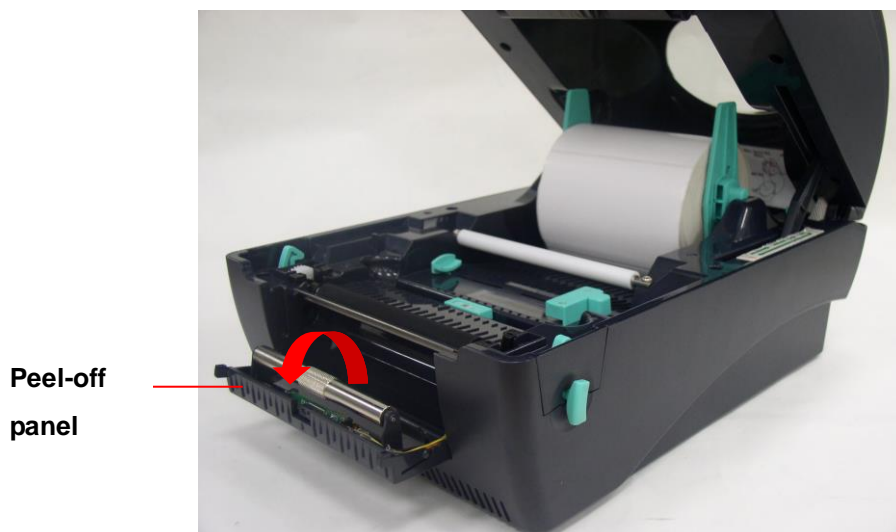

5. Feed the paper, printing side facing up, through the paper guide and pass over the platen.
6. Lead the paper through the backing paper opening, beneath the roller, and tear off one piece of the label.
7. Adjust the paper guide by removing left or right to fit the paper width.

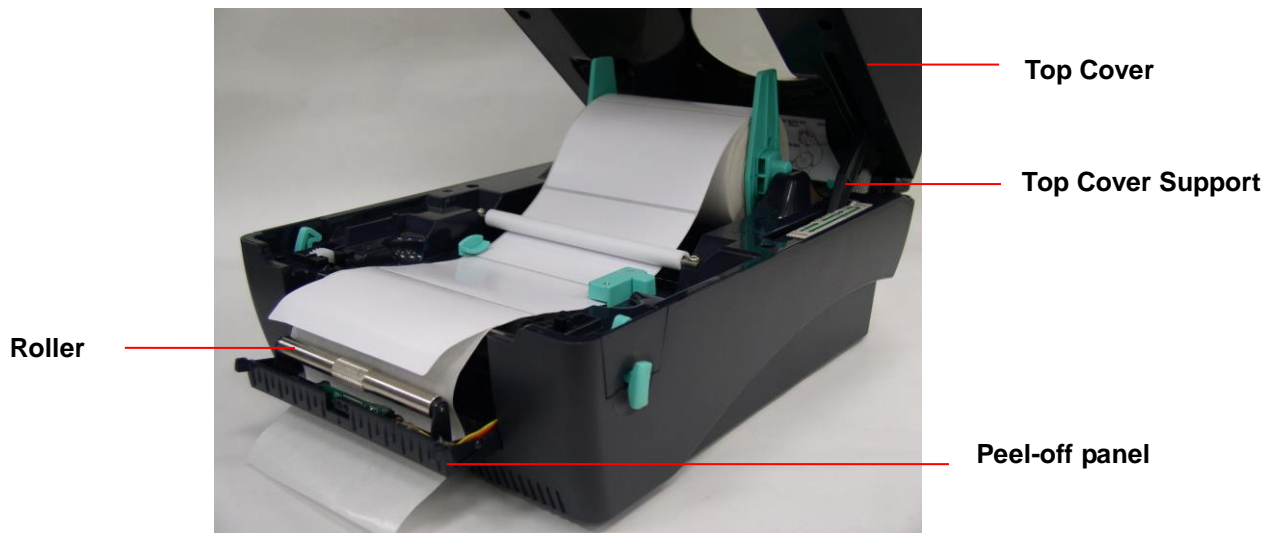

Lead the paper through the backing paper opening, beneath the roller

8. Push the peel-off panel back to the printer.
9. Close the top cover by lifting up the top cover support and close the top cover slowly.

Note: Pull the label outward tightly after closing the top cover.



Complete label installation for peel-off mode

3.16. Install Cutter Module (Option)

1. Place the printer upside down and unscrew the two screws of the hinge holder on the lower cover.
2. Unscrew the screw of the memory card cover.

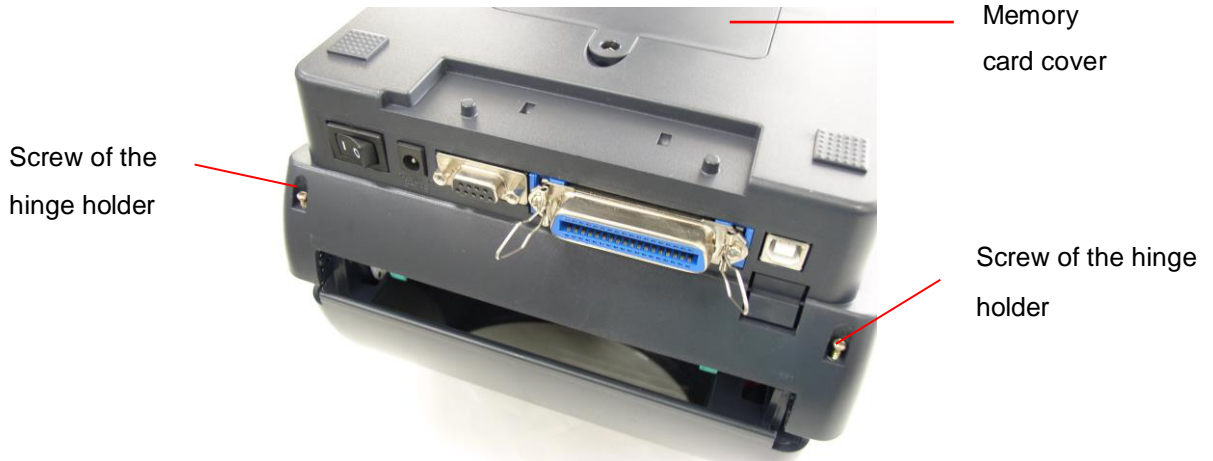

3. Plug in the cutter driver IC socket on the main board.

<p>98-0250154-9A/9B/9C/9D/9ELF main board assembly / U30</p>	<p>98-0250154-AA/AB/AC/AD/AELF (or later versions) main board assembly / U30</p>

Use cutter driver IC A3953SB or A4973SB

Use cutter driver IC A4973SB only

Note:

*The cutter driver IC A3953SB is not compatible with 98-0250154-AA/AB/AC/AD/AELF series main board assembly.

*Please make sure the direction of cutter driver IC shown as below:

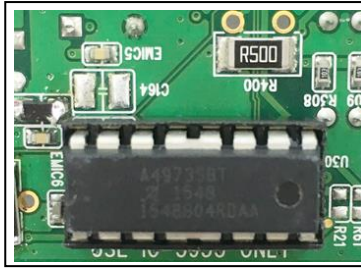

4. Open the top cover of the printer by pushing the top cover opening levers to the paper outlet direction. The top cover support will hold the top cover of the printer.

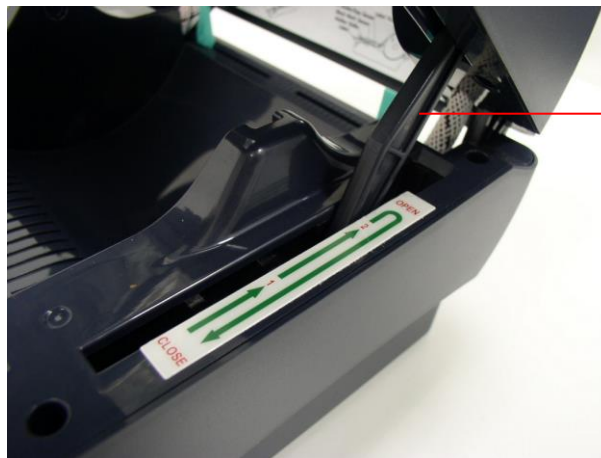

Top cover support

5. Open the top cover and hold it and push the top cover support down and backwards and then push the top cover backwards.



6. Pull up the front panel from the lower cover.

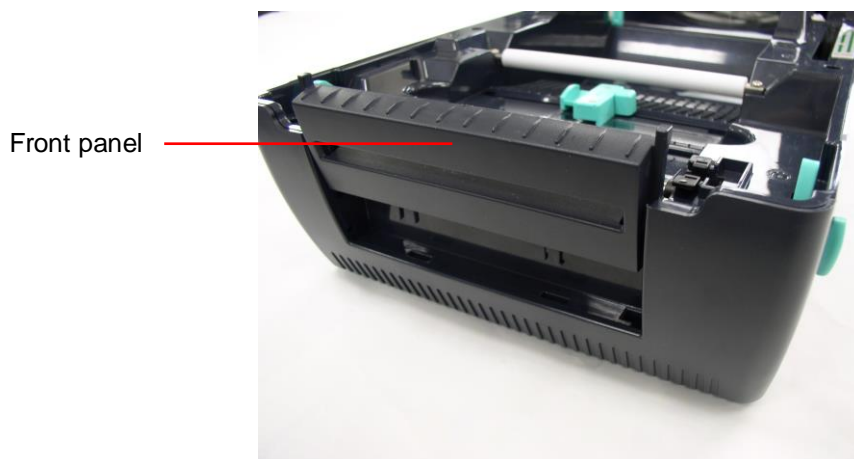

7. Unscrew the 6 screws in lower inner cover

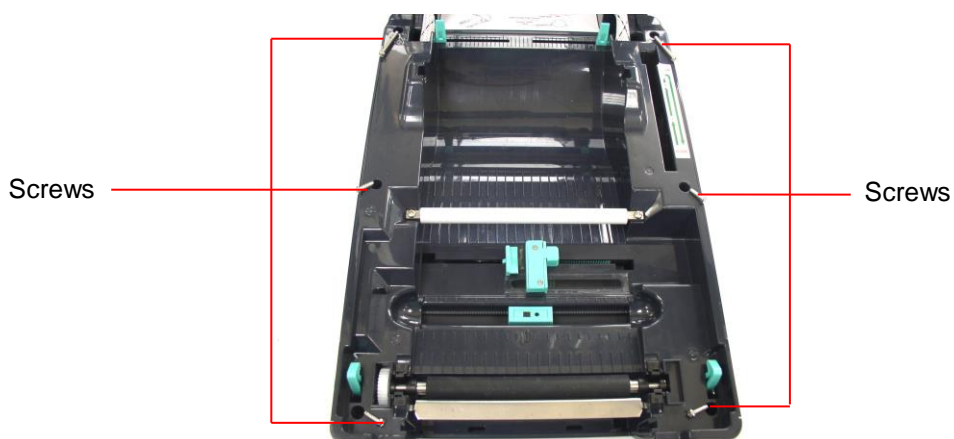

8. Lift up the lower inner cover to separate the lower inner cover from the lower cover.
9. Put the cable of the 4-pin connector through the slot of lower inner cover front side. Connect the cutter module cable to the 4-pin socket on the location JP10 of the printer PCB. Then, put back the lower inner cover.

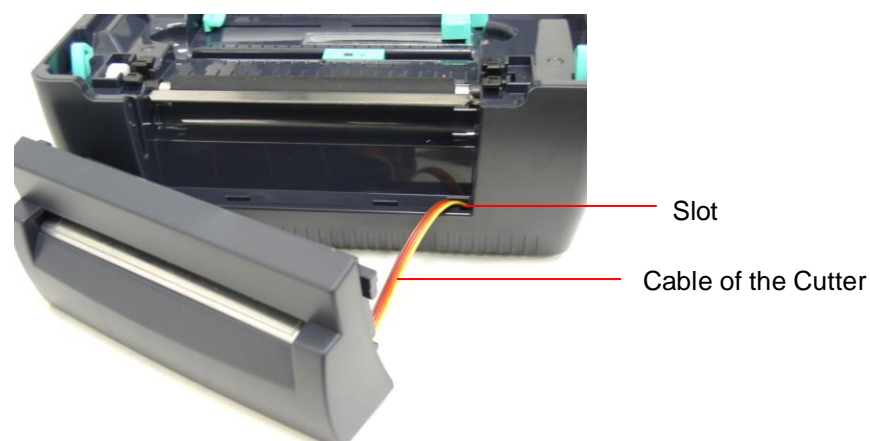

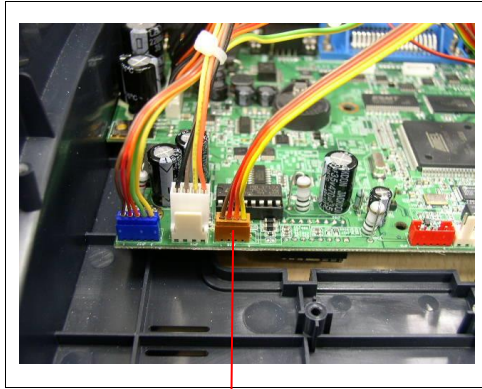

Location JP38

10. Gently place the cutter module into the two niches of lower inner cover front side, then push cutter to lock into the lower inner cover.

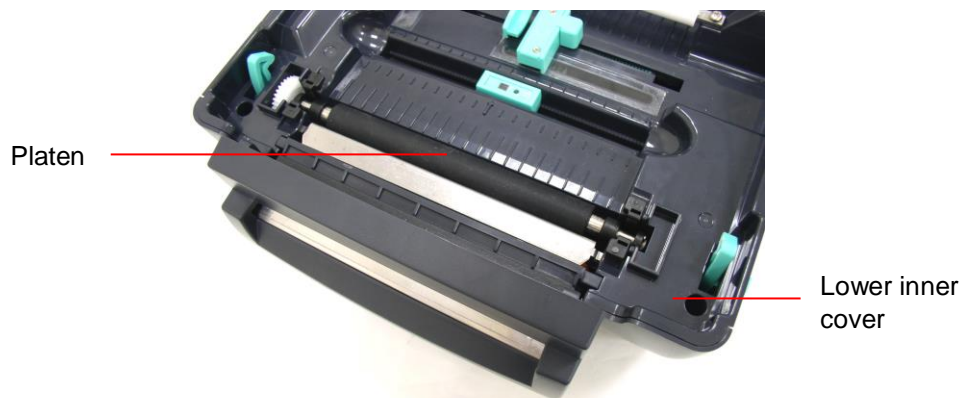

11. Screw back the memory card cover.
12. Reassemble the module in reverse procedures after installing.

3.17. Loading Label in Cutter Mode

1. Insert a 1" label spindle into a paper roll.
2. Open the top cover of the printer.
3. Install a paper roll on the paper roll mount.
4. Feed the paper, printing side face up, through the paper guide and pass over the platen.
5. Feed the paper through the cutter paper opening.
6. Adjust the paper guide by removing it left or right to fit the paper width.

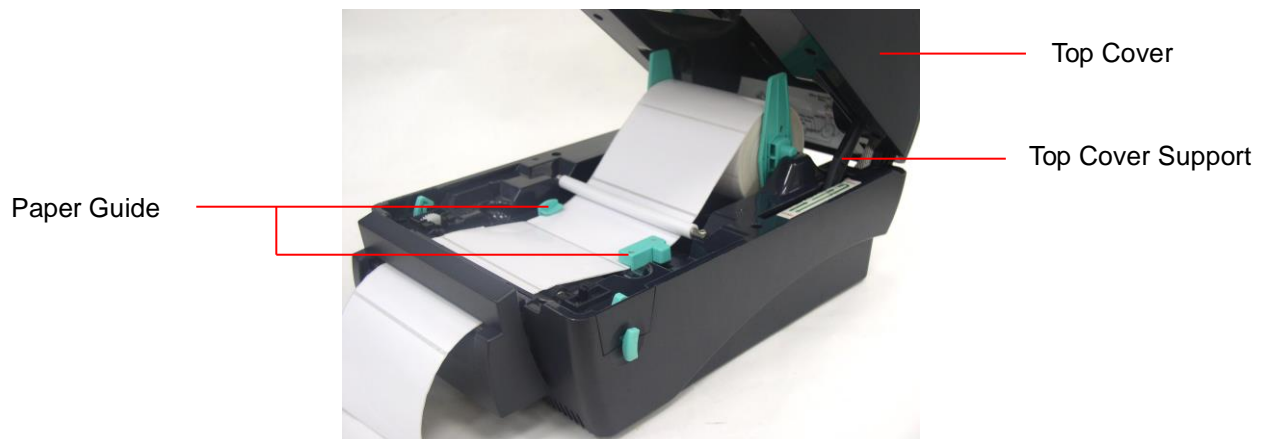

7. Close the top cover by lifting up the top cover support and close the top cover slowly.



Complete label installation in cutter mode

Note:

- * Except for the linerless cutter, all regular/ heavy duty/ care label cutters DO NOT cut on media with glue. For more details, please refer to the cutter specification in the user's manual.
- * Specifications, accessories, parts and programs are subject to change without notice.

3.18. Internal Ethernet Interface Installation (Option)

1. Break through the plastic partial tab at the rear side of lower cover to get the RJ45 interface opening.

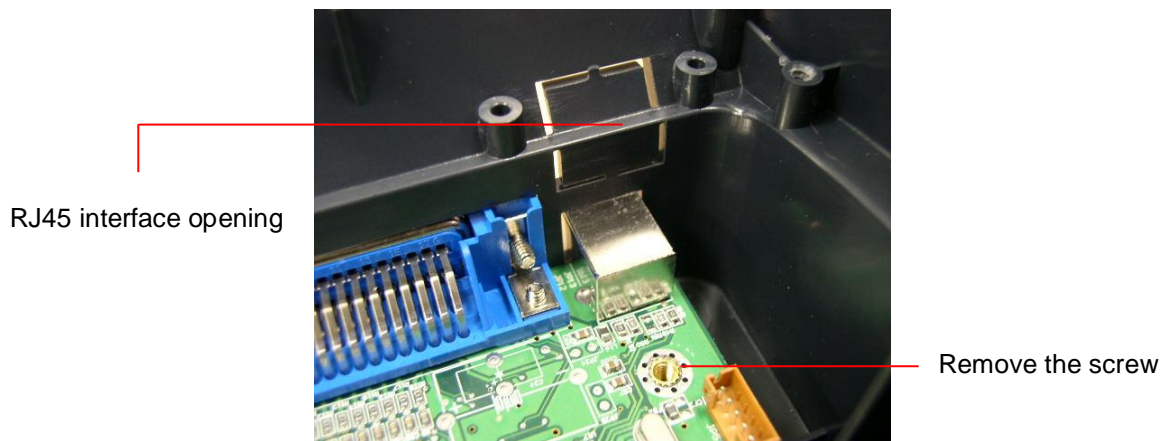

2. Remove the screw from the main board. Fasten the copper pillar.

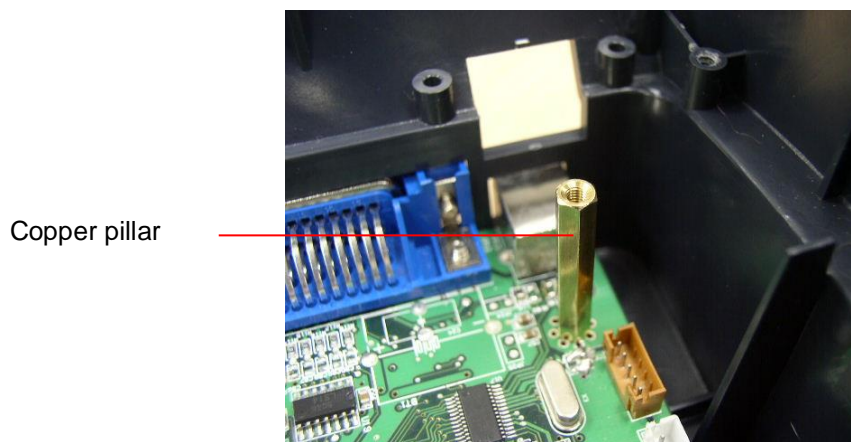

3. Plug the RJ45 cable connector to the RJ45 daughter board connector. Fasten the RJ45 connector daughter board upon the lower cover and copper pillar. The ground wire from the mechanism must be screwed on the daughter board at copper pillar.

Screws

Ground wire

RJ45 connect
daughter board

RJ45 / 8 PIN connector
interface cable interface cable

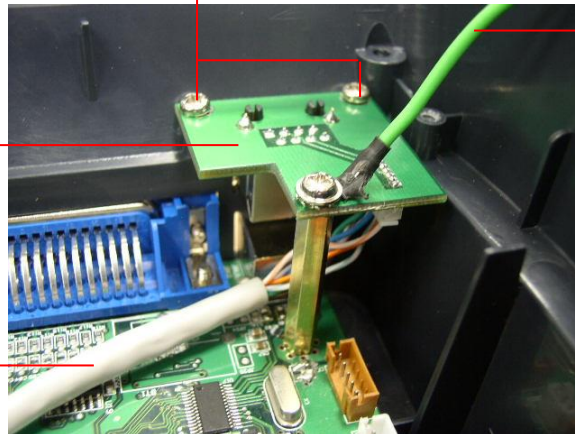

4. Plug the 8 pin RJ45 cable to the main board JP43 connector.

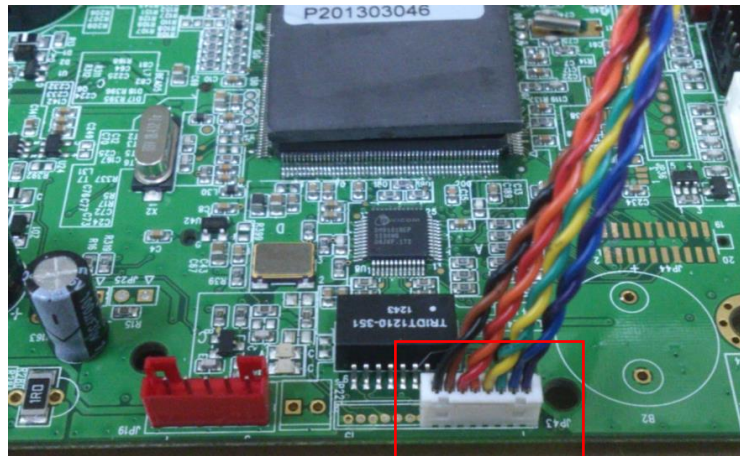

Note: This internal Ethernet interface only supports with the main board that has print server function on board.

4. Power on Utilities

There are six power-on utilities to set up and test printer hardware. These utilities are activated by pressing FEED button and by turning on the printer power simultaneously.

The utilities are listed as below:

1. Ribbon sensor calibration ; Gap/black mark sensor calibration
2. Gap/black mark sensor calibration ; Self-test and dump mode
3. Printer initialization
4. Black mark sensor calibration
5. Gap sensor calibration
6. Skip AUTO.BAS

4.1 Ribbon and Gap/Black Mark Sensor Calibration

Gap/black mark sensor sensitivity should be calibrated at the following conditions:

1. A brand new printer
2. Change label stock.
3. Printer initialization.

Please follow the steps below to calibrate the ribbon and gap/black sensor.

1. Turn off the power switch.
2. Hold on the button then turn on the power switch.
- 3 Release the button when LED becomes **red** and blinking. (Any red will do during the 5 blinks).
 - It will calibrate the ribbon sensor and gap/black mark sensor sensitivity.
 - The LED color will be changed as following order :
Amber → **red (5 blinks)** → amber (5 blinks) → green (5 blinks) → green/amber (5 blinks) → red/amber (5 blinks) → solid green

Note:

Please select gap or black mark sensor by GAP or BLINE command prior to calibrate the sensor.

For more information about GAP and BLINE command, please refer to TSPL2 programming manual.

4.2 Gap/Black Mark Calibration ; Self-test ; Dump mode

While calibrate the gap/black mark sensor, printer will measure the label length, print the internal configuration (self-test) and then enter the dump mode. To calibrate gap or black mark sensor, depends on the sensor setting in the last print job.

Please follow the steps below to calibrate the sensor.

1. Turn off the power switch.
2. Hold on the button then turn on the power switch.
3. Release the button when LED becomes **amber** and blinking. (Any amber will do during the 5 blinks).
 - The LED color will be changed as following order.
Amber → red (5 blinks) → **amber (5 blinks)** → green (5 blinks) → green/amber (5 blinks) → red/amber (5 blinks) → solid green
 1. It calibrates the sensor and measures the label length and prints internal settings then enter the dump mode.

Note:

Please select gap or black mark sensor by Diagnostic Tool or by GAP or BLINE command prior to calibrate the sensor.

For more information about GAP and BLINE command, please refer to TSPL2 programming manual.

Dump mode

Printer will enter dump mode after printing printer configuration. In the dump mode, all characters will be printed in 2 columns as following. The left side characters are received from your system and right side data are the corresponding hexadecimal value of the characters. It allows users or engineers to verify and debug the program.

<p>ASCII Data →</p>	<pre> SPEED 2.0 53 50 45 45 44 20 32 2E 30 0D DENSITY 8 0A 44 45 4E 53 49 54 59 20 38 SET PEEL 0D 0A 53 45 54 20 50 45 45 4C OFF DIRE 20 4F 46 46 0D 0A 44 49 52 45 CTION 0 g 43 54 49 4F 4E 20 30 0D 0A 47 AP 3.00 mm 41 50 20 33 2E 30 30 20 6D 6D .0.00 mm 2C 30 2E 30 30 20 6D 6D 0D 0A REFERENCE 52 45 46 45 52 45 4E 43 45 20 0.0 SET C 30 2C 30 0D 0A 53 45 54 20 43 UTTER OFF 55 54 54 45 52 20 4F 46 46 0D SIZE 100. 0A 53 49 5A 45 20 31 30 30 2E 02 mm,65.0 30 32 20 6D 6D 2C 36 35 2E 30 4 mm CLS 34 20 6D 6D 0D 0A 43 4C 53 0D BARCODE 1 0A 42 41 52 43 4F 44 45 20 31 44,149,"39 34 34 2C 31 34 39 2C 22 33 39 ",120,1,0. 22 2C 31 32 30 2C 31 2C 30 2C 2.6,"57114 32 2C 36 2C 22 35 37 31 31 34 38T" PRIN 33 38 54 22 0D 0A 50 52 49 4E T 1.1 SPE 54 20 31 2C 31 0D 0A 53 50 45 ED 2.0 DE 45 44 20 32 2E 30 0D 0A 44 45 NSITY 8 S 4E 53 49 54 59 20 38 0D 0A 53 ET PEEL OF 45 54 20 50 45 45 4C 20 4F 46 F DIRECTI 46 0D 0A 44 49 52 45 43 54 49 ON 0 GAP 4F 4E 20 30 0D 0A 47 41 50 20 3.00 mm,0. 33 2E 30 30 20 6D 6D 2C 30 2E 00 mm REF 30 30 20 6D 6D 0D 0A 52 45 46 ERENCE 0,0 45 52 45 4E 43 45 20 30 2C 30 SET CUTT 0D 0A 53 45 54 20 43 55 54 54 ER OFF SI 45 52 20 4F 46 46 0D 0A 53 49 ZE 100.02 5A 45 20 31 30 30 2E 30 32 20 mm,65.04 m 6D 6D 2C 36 35 2E 30 34 20 6D m CLS BA 6D 0D 0A 43 4C 53 0D 0A 42 41 RCODE 144, 52 43 4F 44 45 20 31 34 34 2C 149,"39",1 31 34 39 2C 22 33 39 22 2C 31 20,1,0,2,6 32 30 20 31 2C 30 2C 32 2C 36 ,"5711438T 2C 22 35 37 31 31 34 33 38 54 " PRINT 1 22 0D 0A 50 52 49 4E 54 20 31 .1 2C 31 0D 0A </pre>	<p>→ Hex decimal data related to left column of ASCII data</p>
---------------------	--	--

Fig. 4 Dump mode printout

Note:

Turn off / on the power to resume printer for normal printing.

4.3 Printer Initialization

Printer initialization is used to clear DRAM and restore printer settings to defaults. The only one exception is ribbon sensitivity, which will not be restored to default.

Printer initialization is activated by the following procedures.

1. Turn off the power switch.
2. Hold on the button then turn on the power switch.
3. Release the button when LED turns **green** after 5 amber blinks. (Any green will do during the 5 blinks).
 - The LED color will be changed as following:
Amber → red (5 blinks) → amber (5 blinks) → **green (5 blinks)** → green/amber (5 blinks) → red/amber (5 blinks) → solid green

Printer configuration will be restored to defaults as below after initialization.

Parameter	Default setting
Speed	203 dpi: 127 mm/sec (5 ips) 300 dpi: 76 mm/sec (3 ips)
Density	8
Label Width	4" (101.6 mm)
Label Height	4" (101.6 mm)
Sensor Type	Gap sensor
Gap Setting	0.12" (3.0 mm)
Print Direction	0
Reference Point	0,0 (upper left corner)
Offset	0
Tear Mode	On
Peel off Mode	Off
Cutter Mode	Off
Serial Port Settings	9600 bps, none parity, 8 data bits, 1 stop bit
Code Page	850
Country Code	001
Clear Flash Memory	No
IP Address	DHCP

Note :

Always do gap/black mark sensor calibration after printer initialization.

4.4 Black Mark Sensor Calibration

Set black mark sensor as media sensor and calibrate the black mark sensor.

Please follow the steps as below.

1. Turn off the power switch.
2. Hold on the button then turn on the power switch.
3. Release the button when LED turns **green/amber** after 5 green blinks. (Any green/amber will do during the 5 blinks).
 - The LED color will be changed as following:
Amber → red (5 blinks) → amber (5 blinks) → green (5 blinks) → **green/amber (5 blinks)** → red/amber (5 blinks) → solid green

4.5 Gap Sensor Calibration

Set gap sensor as media sensor and calibrate the gap sensor.

Please follow the steps as below.

1. Turn off the power switch.
2. Hold on the button then turn on the power switch.
3. Release the button when LED turns **red/amber** after 5 green/amber blinks. (Any red/amber will do during the 5 blinks).
 - The LED color will be changed as following:
Amber → red (5 blinks) → amber (5 blinks) → green (5 blinks) → green/amber (5 blinks) → **red/amber (5 blinks)** → solid green

4.6 Skip AUTO.BAS

TSPL2 programming language allows user to download an auto execution file to flash memory. Printer will run the AUTO.BAS program immediately when turning on printer power. The AUTO.BAS program can be interrupted without running the program by the power-on utility.

Please follow the procedures below to skip an AUTO.BAS program.

1. Turn off printer power.
2. Press the FEED button and then turn on power.
3. Release the FEED button when LED becomes **solid green**.
 - The LED color will be changed as following:

Amber → red (5 blinks) → amber (5 blinks) → green (5 blinks) → green/amber (5 blinks) → red/amber (5 blinks) → **solid green**

2. Printer will be interrupted to run the AUTO.BAS program.

5. GAP AND BLACK MARK SENSOR SELECTION

Gap Sensor selection

- Default setting. No extra action necessary.
- If you want to change sensor type from black mark sensor to gap sensor, please do printer initialization (refer to Initialization section).

Black Mark Sensor

- Start Label View XLT+ or Nice Label LE software.
- Set label side in the software and select black mark sensor as sensor type.
- Install label media with black mark or hole for registration.
- Print one label to switch sensor from gap to black mark sensor.

Remember, always do sensor calibration after sensor selection (refer to Gap and Black Mark Sensor Calibration section).

6. BIOS Update

If printer BIOS update is required, please do the following steps.
Update the BIOS file and reset the printer.

Update File

1. Make sure the printer is at ready status and the LED is solid **green**.
2. Copy the BIOS file to printer parallel port by the following command at MS-DOS prompt mode.
C:\>COPY TTP-245P.NEW /B LPT1 <Enter>
3. During BIOS updating process, the LED will blink **red** and **orange** alternately. When BIOS update is completed, printer will reset automatically and LED will become **solid green**.

7. DIAGNOSTIC TOOL

The Diagnostic Utility is a toolbox that allows users to explore the printer's settings and status; change printer settings; download graphics, fonts, and firmware; create printer bitmap fonts; and to send additional commands to the printer. Using this convenient tool, you can explore the printer status and settings and troubleshoot the printer.

Note: This utility works with printer firmware V6.00 and later versions.

7.1 Start the Diagnostic Tool

1. Double click on the Diagnostic tool icon  `DiagTool.exe` to start the software.
2. There are four features (Printer Configuration, File Manager, Bitmap Font Manager, Command Tool) included in the Diagnostic utility.

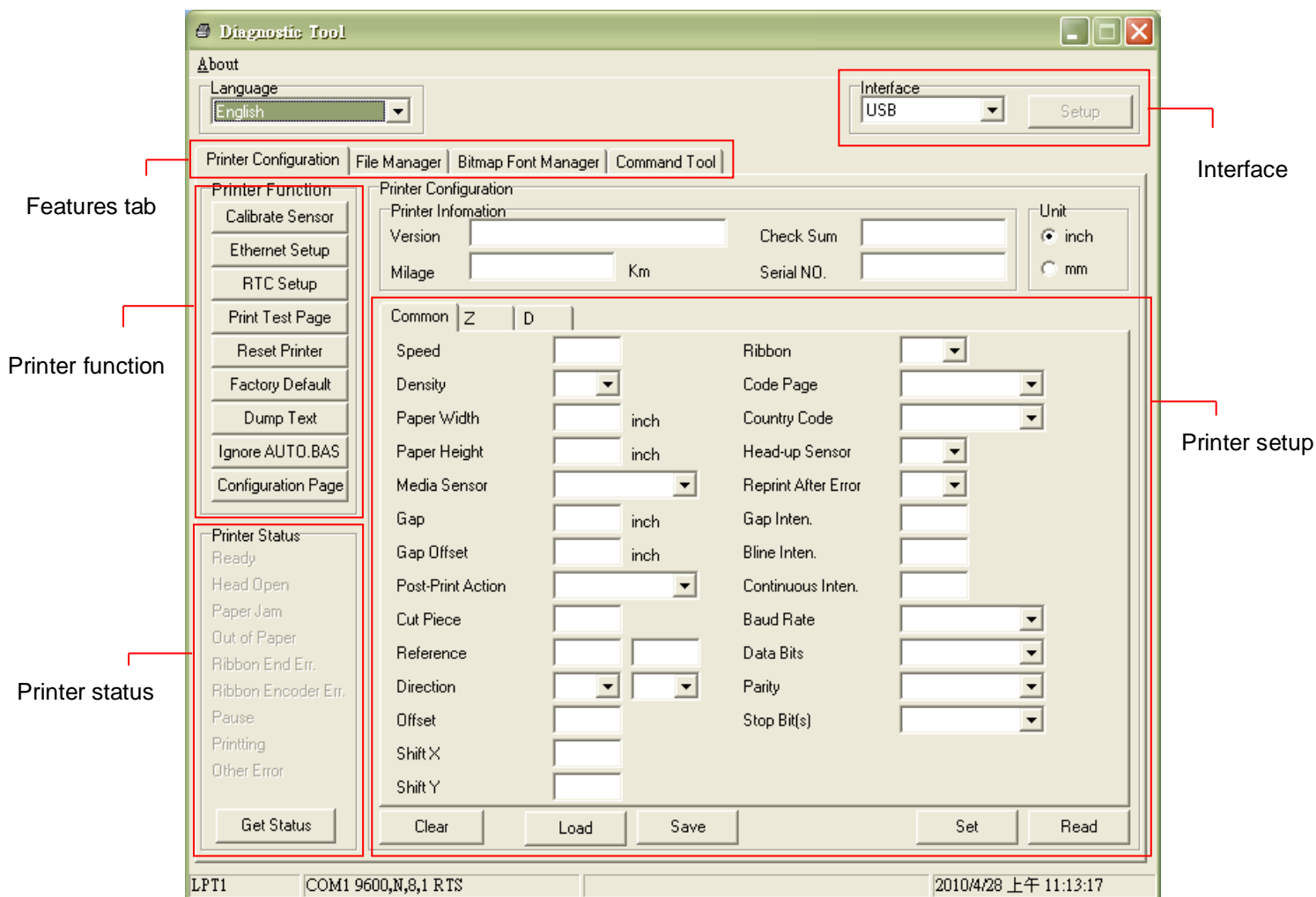

7.2 Printer Function (Calibrate sensor, Ethernet setup, RTC setup.....)

1. Select the PC interface connected with bar code printer.
2. Click the “Function” button to setting.
3. The detail functions in the Printer Function Group are listed as below.

Printer Function	Function	Description
Calibrate Sensor	Calibrate Sensor	Calibrate the sensor specified in the Printer Setup group media sensor field
Ethernet Setup	Ethernet Setup	Setup the IP address, subnet mask, gateway for the on board Ethernet
RTC Setup	RTC Time	Synchronize printer Real Time Clock with PC
Print Test Page	Print Test Page	Print a test page
Reset Printer	Reset Printer	Reboot printer
Factory Default	Factory Default	Initialize the printer and restore the settings to factory default.
Dump Text	Dump Text	To activate the printer dump mode.
Ignore AUTO.BAS	Ignore AUTO.BAS	Ignore the downloaded AUTO.BAS program
Configuration Page	Configuration Page	Print printer configuration

Note:

For more information about Diagnostic Tool, please refer to the diagnostic utility quick start guide in the CD disk \ Utilities directory.

8. TROUBLESHOOTING

This section lists the common problems that you may encounter when operating the printer.

2. **LED does not light on**

- Turn the power switch on.
- Measure if there is 24V DC from the power supply output plug. Change the power adaptor if 24V DC is not been measured.
- Check if U32 (5VDC) and U22 (3.3VDC) of the main board are broken. Change main board if one of them is broken; Or measure if JP 22 (5VDC) and the terminal of R316 close to C139 side (3.3VDC) are correct voltage. Change main board if their voltages are been measured incorrectly.

3. **The printer is paused**

- Press the FEED button to resume printing.

4. **The LED is on red and blinking**

If the LED is red and blinking, which means that either the label runs out, paper sensor error, ribbon runs out, ribbon sensor error or ribbon rewind encode sensor error. We also can use diagnostic tool to get the printer status through COM port or USB port.

Label runs out (Out of paper):

- Load a roll of label and follow the instructions as following and then press the feed button to resume printing.
 1. Insert a 1" label spindle into a paper roll
 2. Open the printer's top cover by releasing the green top cover open levers located on each side of the printer and lifting the top cover. A top cover support at the rear of the printer will hold the printer top cover open.
 3. Place a roll of paper onto the center of the paper roll mount.
 4. Feed the paper, printing side face up, through the Teflon bar and the label guide and pass over the platen.
 5. Adjust the green center-biased label guides in or out so they are slightly touch the edges of the label backing.
 6. To close the printer top cover, lift the cover slightly and pull the top cover support forward toward the front of the printer. Close the printer top cover slowly and make sure the cover locks latch securely.

Paper Jam

- Select the correct sensor type.

- Calibrate the sensor by clicking the “Calibrate Sensor” button and select the sensor type for sensor calibration.

Ribbon runs out (out of ribbon):

- Load a roll of ribbon and follow the instructions as following and then press the feed button to resume printing.
 1. Push down on the ribbon access window to unlock and open the cover
 2. Place a paper core on a ribbon rewind spindle.
 3. Mount the ribbon rewind paper core on the front hubs.
 4. Install a ribbon on the ribbon supply spindle.
 5. Mount the ribbon supply spindle on the rear hubs.
 6. Attach the ribbon leader to the ribbon rewind paper core.
 7. Rotate the ribbon rewind paper core until the ribbon leader is thoroughly, firmly encompassed by the black section of the ribbon.
 8. Close the ribbon access window.

Ribbon sensor or ribbon rewind encoder error (out of ribbon):

- Remove the ribbon, close the ribbon mechanism then turn off/on the printer power. The printer will be switched to thermal direct mode automatically. If the printer LED is still on red blink, please check the following:
 - A. Is a paper core installed on the ribbon rewind spindle?
 - B. Is ribbon installed correct along the ribbon path?
 - C. Is the ribbon too transparent?
 - D. Is the rib of the ribbon spindle is broken?
 - E. Is the ribbon gear broken or worn?
 - F. Turn off printer power. Rewind the ribbon spindle by hand. Does the spindle rewind smoothly by hand? If the ribbon spindle doesn't rewind smoothly, please replace the ribbon mechanism.
 - G. Is the DC motor broken?
 - H. Is the ribbon end sensor broken?
 - I. Is the DC motor encoder sensor broken?
 Measure the current of pin2 of JP37. When sensor detects the gap of encoder, it is 5V DC; otherwise it should be 0V DC.
 Check if there is any black lubricant oil filled between gaps, which may cause error.
 - J. Check the DC motor driver IC (U29) on the main board. If it can function all right, please replace the main board.

Paper sensor error

Please check the following items:

- A. Is label installed correctly? Please refer to previous 3. *The LED is on with red*

blinking – Label runs out to load a roll of label and then press the FEED button to resume printing.

- B. Is there any label stuck on the label sensor? Is there any pre-printed logo on the label? Please refer to 4.3 Printer Initialization to reset the system.

If the pre-printed logo or text influences the auto gap calibration function, please calibrate the gap sensor with proper sensitivity setting by try and error method.

Example:

C:\>COPY CON LPT1 <Enter>

SET GAP 1 <Ctrl> <Z>

Main board, gap sensor or black sensor failure.

- If you confirm the main board is good, Please change the gap sensor receiver first, because the receiver sensor failure rate is higher than the transmitter sensor.

5. **The printer setting runs error.**

Printer setting runs error:

Refer to 4.3 Initialization to reset the system.

6. **Continuous feeding labels**

- The printer setting may go wrong. Please do “Printer Initialization” and “Gap and Black Mark Sensor Calibration”. (Refer to 4.2 and 4.3).

7. **No print on the label**

- Is the label or ribbon loaded correctly? Refer to No, 3 Label runs out and Ribbon runs out to load the paper or to load the ribbon.
- Does the ribbon run out?
- Is the thermal head connector connected?
- Is the thermal head broken? Check it by printer self-test printout.
- Is main PCB U14, U15, Q1 or Q2 broken?

8. **Printer does not print.**

Printed by enclosed BarTender

- This may be driver conflict problem. Please remove all the drivers in the printer folder and then re-install the driver for your printer.

Printed by printer command (other error).

- This problem is caused by incorrect syntax commands. This printer will ignore incorrect syntax commands. Please set the printer to the dump mode and make sure the printed command is identical to the commands sent from the

application software.

- The printer serial port setting is not correspondent to the PC's setting
Please do the configuration by the following commands.

```
C:\>COPY CON LPT1 <Enter>
```

```
SET COM1 96,N,8,1 <Enter>
```

```
<Ctrl>Z<Enter>
```

```
C:\>
```

9. **Poor print quality**

- The dust or glue from label may stick onto the print head. Wipe the thermal print head by the soft cloth soaked with Ethanol.
- Adjust the print density setting.
- Ribbon and paper media are not compatible.
- If this problem happens after changing a new print head module, adjust the print head's heater line position by re-assembling print head module.

10. **Stepping motor does not feed label**

- Is stepping motor function abnormal?.
- Check if U18, and U19 (3717 driver IC) of main board are broken?

11. **LED keeps at solid amber.**

- Is switching power broken?
- Is main board broken? Please replace a new main board.
- Try to update the firmware on line. Press the FEED and power on the printer at same time. Press the FEED again while the first green LED is on. Finally, transmit the firmware program to the printer from PC.

12. **Cutter functions abnormally.**

Cutter is not activated (other error)

At first, check if cutter is broken or the main PCB is damaged. If it still has problem after changing a new cutter, perhaps the U30 (driver IC), U28 IC or U34 on the main board was broken. Otherwise, check if the pin 28 of U2 (CPU) is good.

13. **Black mark can't be detected properly (out of paper or paper jam)**

- Please check if the position of the black mark on label is correspondent with black mark sensor.
- Is the width of black mark on label too thin to be detected? The recommended black mark width is wider than 12 mm.

9. MAINTENANCE

This session presents the clean tools and methods to maintain your printer.

1. Please use one of following material to clean the printer.

- Cotton swab (Head cleaner pen)
- Lint-free cloth
- Vacuum / Blower brush
- 100% ethanol

1. The cleaning process is described as following

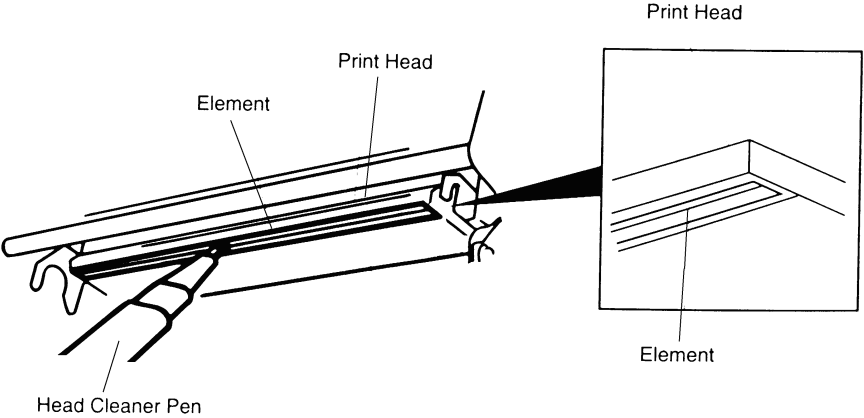
Printer Part	Method	Interval
<p>Print Head</p>	<p>1. Always turn off the printer before cleaning the print head. 2. Allow the print head to cool for a minimum of one minute. 3. Use a cotton swab (Head cleaner pen) and 100% ethanol to clean the print head surface.</p>	<p>Clean the print head when changing a new label roll</p>
 <p>The diagram illustrates the cleaning of the print head. It shows a hand holding a 'Head Cleaner Pen' and applying it to the 'Print Head' surface. The 'Print Head' is shown in a perspective view, with a callout box providing a magnified view of the 'Element' (the nozzle area). Labels include 'Print Head', 'Element', and 'Head Cleaner Pen'.</p>		
<p>Platen Roller</p>	<p>1. Turn the power off. 2. Rotate the platen roller and wipe it thoroughly with 100% ethanol and a cotton swab, or lint-free cloth.</p>	<p>Clean the platen roller when changing a new label roll</p>
<p>Tear Bar/Peel Bar</p>	<p>Use the lint-free cloth with 100% ethanol to wipe it.</p>	<p>As needed</p>
<p>Sensor</p>	<p>Compressed air or vacuum</p>	<p>Monthly</p>
<p>Exterior</p>	<p>Wipe it with water-dampened cloth</p>	<p>As needed</p>

Interior	Brush or vacuum	As needed
-----------------	-----------------	-----------

Note:

- Do not touch printer head by hand. If you touch it carelessly, please use ethanol to clean it.
- Please use 100% Ethanol. DO NOT use medical alcohol, which may damage the printer head.
- Regularly clean the print head and supply sensors once change a new ribbon to keep printer performance and extend printer life.

UPDATE HISTORY

Date	Content	Editor
2008/4/17	Add the part no. for Switzerland type power cord	Camille
2008/4/22	Revise the description for 98-0250184-00LF (Main board ass'y with internal print server kit)	Camille
2008/5/14	Revise the black mark sensor assembly part no.	Camille
2008/5/27	Revise the print head harness part no. from 70-52B2604-11LF to 72-0250008-00LF	Camille
2008/6/16	1. Revise the hinge holder part no. 2. Revise the TPH plastic bracket part no.	Camille
2008/7/11	Remove the parts list section	Camille
2008/12/12	Add connector JP6 description	Camille
2009/3/16	Modify section 3.13 (Recommended SD card specification)	Camille
2009/10/6	Revise section 2.1	Camille
2010/7/1	*Add TTP-247/TTP-345 printer *Add the section 1.2.2 *Update the section 7	Camille
2011/1/17	Modify section 2.1 and 3.4	Camille
2011/1/25	Modify TSC address	Camille
2011/4/8	Modify section 2.2	Camille
2013/3/13	Modify section 2.1	Camille
2014/8/1	Add section 3.18	Camille
2019/8/6	Modify section 3.16 and 3.17	Kate



TSC Auto ID Technology Co., Ltd.

Corporate Headquarters

9F., No.95, Minquan Rd., Xindian Dist.,
New Taipei City 23141, Taiwan (R.O.C.)

TEL: +886-2-2218-6789

FAX: +886-2-2218-5678

Web site: www.tscprinters.com

E-mail: printer_sales@tscprinters.com
tech_support@tscprinters.com

Li Ze Plant

No.35, Sec. 2, Ligong 1st Rd., Wujie Township,
Yilan County 26841, Taiwan (R.O.C.)

TEL: +886-3-990-6677

FAX: +886-3-990-5577