

Identive Infrastructure

Reference Manual – version 1.0



CLOUD 47x0 F

Dual Interface Smartcard Readers

Reference manual

CLOUD 47x0 F Dual Interface Smartcard Readers

© Identive GmbH

Oskar-Messter-Strasse, 13

85737 Ismaning

Germany

Phone +49 89 9595 5000 • Fax +49 89 9595 5555

Document history

Date	Version	Description of change
01/24/2013	1.0	Initial Version

Contact information

[CLOUF 4700 F](#)

[CLOUD 4710F](#)

For sales information, please email sales@identive-infrastructure.com

Table of Contents

1. Legal information	9
1.1. Disclaimers	9
1.2. Licenses	9
1.3. Trademarks	9
2. Introduction to the manual	10
2.1. Objective of the manual	10
2.2. Target audience	10
2.3. Product version corresponding to the manual	10
2.4. Definition of various terms and acronyms	11
2.5. References	12
2.6. Conventions	13
3. General information about CLOUD 47x0 F	14
3.1. CLOUD 47x0 F key benefits	14
3.2. CLOUD 47x0 F key features	14
3.3. CLOUD 47x0 F ordering information	15
3.4. Available options	15
3.5. CLOUD 47x0 F customization options	15
3.6. Contactless communication principles and CLOUD 47x0 F usage recommendations	16
3.6.1. Power supply	16
3.6.2. Data exchange	16
3.6.3. Recommendations	17
3.7. Applications	17
3.7.1. General	17
3.7.2. Applications provided by Identive GmbH	18
4. CLOUD 47x0 F characteristics	19
4.1. CLOUD 47x0 F high level architecture	19
4.1.1. Block diagram	19
4.1.2. Software architecture	20
4.2. Quick reference data	21
4.2.1. CLOUD 47x0 F dimensions	21
4.2.2. LED behavior	22
4.2.3. Other data	22
4.2.3.1. General	22
4.2.3.2. USB	23
4.2.3.3. Contact card interface	23
4.2.3.4. Contactless interface	23
5. Software modules	24
5.1. Installation	24
5.2. Utilities	24
5.3. Driver	24
5.3.1. CLOUD 47x0 F listing	24

5.3.2.	Supported operating systems	24
5.3.3.	PC/SC 2.0 compliant ATR for contactless interface	25
5.3.3.1.	ATR for contactless storage user tokens	25
5.3.3.2.	ATR for ISO/IEC 14443-4 user tokens	26
5.4.	Firmware	27
5.4.1.	CCID transport protocol	27
5.4.1.1.	CCID class requests supported	27
5.4.1.2.	CCID messages supported	27
5.4.1.3.	CCID Error Codes	27
6.	Commands description	29
6.1.	Generic APDU	29
6.1.1.	Working with DESFire and MIFARE Plus tokens	29
6.1.2.	PAPDU_GET_UID	29
6.1.3.	PAPDU_ESCAPE_CMD	29
6.2.	Supported Pseudo APDU (Contactless Interface)	31
6.2.1.	PAPDU_MIFARE_READ_BINARY	31
6.2.2.	PAPDU_MIFARE_UPDATE_BINARY	32
6.2.3.	PAPDU_MIFARE_LOAD_KEYS	33
6.2.4.	PAPDU_MIFARE_AUTHENTICATE	35
6.2.5.	PAPDU_MIFARE_READ_SECTOR	36
6.2.6.	PAPDU_MIFARE_READ_SECTOR_EX	37
6.2.7.	PAPDU_MIFARE_WRITE_SECTOR	38
6.2.8.	PAPDU_MIFARE_VALUE_BLK_OLD	38
6.2.9.	PAPDU_MIFARE_VALUE_BLK_NEW	40
6.2.10.	PAPDU_TCL_PASS_THRU (T=CL Pass Thru)	41
6.2.11.	PAPDU_ISO14443_PART3_PASS_THRU (Mifare Pass Thru)	42
6.2.12.	PAPDU_ISO14443_PART4_PART3_SWITCH (TCL – Mifare Switch)	42
6.2.13.	PAPDU_FELICA_REQC	43
6.2.14.	PAPDU_FELICA_REQ_SERVICE	43
6.2.15.	PAPDU_FELICA_REQ_RESPONSE	44
6.2.16.	PAPDU_FELICA_READ_BLK	44
6.2.17.	PAPDU_FELICA_WRITE_BLK	45
6.2.18.	PAPDU_FELICA_SYS_CODE	45
6.2.19.	PAPDU_NFC_TYPE1_TAG_RID	46
6.2.20.	PAPDU_NFC_TYPE1_TAG_RALL	46
6.2.21.	PAPDU_NFC_TYPE1_TAG_READ	47
6.2.22.	PAPDU_NFC_TYPE1_TAG_WRITE_E	47
6.2.23.	PAPDU_NFC_TYPE1_TAG_WRITE_NE	48
6.2.24.	PAPDU_NFC_TYPE1_TAG_RSEG	49
6.2.25.	PAPDU_NFC_TYPE1_TAG_READ8	49
6.2.26.	PAPDU_NFC_TYPE1_TAG_WRITE_E8	50
6.2.27.	PAPDU_NFC_TYPE1_TAG_WRITE_NE8	50
6.3.	Escape commands for the CLOUD 47x0 F	51
6.3.1.	Sending Escape commands to CLOUD 47x0 F	51
6.3.2.	Escape command codes	52
6.3.3.	Common for Contact and Contactless Interfaces	52
6.3.3.1.	READER_SETMODE	52
6.3.3.2.	READER_GETMODE	53
6.3.3.3.	READER_GET_IFDTYPE	54
6.3.3.4.	READER_LED_CONTROL	54
6.3.3.5.	READER_GET_INFO_EXTENDED	55

6.3.3.6.	READER_LED_CONTROL_BY_FW	56
6.3.3.7.	READER_RD_WR_USER_AREA	56
6.3.3.8.	READER_GENERIC_ESCAPE	57
6.3.3.9.	READER_CONTROL_CONTACT_SLOT	58
6.3.4.	Specific for Contactless Interface	59
6.3.4.1.	CNTLESS_GET_CARD_INFO	59
6.3.4.2.	CNTLESS_GET_ATS_ATQB	61
6.3.4.3.	CNTLESS_CONTROL_PPS.....	61
6.3.4.4.	CNTLESS_RF_SWITCH	62
6.3.4.5.	CNTLESS_SWITCH_RF_ON_OFF	62
6.3.4.6.	CNTLESS_GET_BAUDRATE.....	63
6.3.4.7.	CNTLESS_CONTROL_RETRIES	64
6.3.4.8.	CNTLESS_CONTROL_POLLING	65
6.3.4.9.	CNTLESS_GET_CARD_DETAILS	65
6.3.4.10.	CNTLESS_SET_CONFIG_PARAMS	67
6.3.4.11.	CNTLESS_IS_COLLISION_DETECTED.....	68
6.3.4.12.	CNTLESS_FELICA_PASS_THRU	68
6.3.4.13.	CNTLESS_P2P_SWITCH_MODES	69
6.3.4.14.	CNTLESS_P2P_TARGET_RECEIVE	72
6.3.4.15.	CNTLESS_P2P_TARGET_SEND	73
6.3.4.16.	CNTLESS_P2P_INITIATOR_DESELECT	73
6.3.4.17.	CNTLESS_P2P_INITIATOR_TRANCEIVE	74
6.3.4.18.	CNTLESS_NFC_SINGLESLOT	75
6.3.4.19.	CNTLESS_NFC_LOOPBACK	75
6.3.4.20.	CNTLESS_GET_SET_NFC_PARAMS.....	76
6.3.4.21.	CNTLESS_GET_P2P_EXTERNAL_RF_STATE	77
6.3.5.	Specific for Contact Interface.....	78
6.3.5.1.	CONTACT_GET_SET_PWR_UP_SEQUENCE	79
6.3.5.2.	CONTACT_EMV_LOOPBACK	80
6.3.5.3.	CONTACT_EMV_SINGLEMODE	81
6.3.5.4.	CONTACT_EMV_TIMERMODE	81
6.3.5.5.	CONTACT_APDU_TRANSFER	82
6.3.5.6.	CONTACT_DISABLE_PPS	82
6.3.5.7.	CONTACT_EXCHANGE_RAW	83
6.3.5.8.	CONTACT_GET_SET_CLK_FREQUENCY	84
6.3.5.9.	CONTACT_CONTROL_ATR_VALIDATION.....	85
6.3.5.10.	CONTACT_GET_SET_MCARD_TIMEOUT	86
6.3.5.11.	CONTACT_GET_SET_ETU	87
6.3.5.12.	CONTACT_GET_SET_WAITTIME.....	88
6.3.5.13.	CONTACT_GET_SET_GUARDTIME	89
6.3.5.14.	CONTACT_READ_INSERTION_COUNTER.....	90
7.	Annexes.....	91

7.1.	Annex A – Status words table	91
7.2.	Annex B – Sample code using escape commands.....	92
7.3.	Annex C – Mechanical drawings.....	95
7.3.1.	Outline and cable positions.....	95
7.3.2.	Stand.....	96
7.3.3.	Reader mounted to Stand.....	97
7.3.4.	CLOUD 4710 F - SAM slot.....	98

1. Legal information

1.1. Disclaimers

The content published in this document is believed to be accurate. Identive GmbH does not, however, provide any representation or warranty regarding the accuracy or completeness of its content and regarding the consequences of the use of information contained herein. If this document has the status “Draft”, its content is still under internal review and yet to be formally validated.

Identive GmbH reserves the right to change the content of this document without prior notice. The content of this document supersedes the content of previous versions of the same document. The document may contain application descriptions and/or source code examples, which are for illustrative purposes only. Identive GmbH gives no representation or warranty that such descriptions or examples are suitable for the application that the reader may want to use them for.

Should you notice problems with the provided documentation, please provide your feedback to support@identive-group.com.

1.2. Licenses

If the document contains source code examples, they are provided for illustrative purposes only and subject to the following restrictions:

- You MAY at your own risk use or modify the source code provided in the document in applications you may develop. You MAY distribute those applications ONLY in form of compiled applications.
- You MAY NOT copy or distribute parts of or the entire source code without prior written consent from Identive GmbH.
- You MAY NOT combine or distribute the source code provided with Open Source Software or with software developed using Open Source Software in a manner that subjects the source code or any portion thereof to any license obligations of such Open Source Software.

If the document contains technical drawings related to Identive GmbH products, they are provided for documentation purposes only. Identive GmbH does not grant you any license to its designs.

1.3. Trademarks

MIFARE™ is a registered trademark of NXP Semiconductors BV.

Windows is a trademark of Microsoft Corporation.

2. Introduction to the manual

2.1. Objective of the manual

This manual provides an overview of the hardware and software features of the CLOUD 47x0 F dual interface smart card readers (CLOUD 4700 F and CLOUD 4710 F).

This manual describes in detail interfaces and supported commands available for developers using CLOUD47x0 F in their applications.

2.2. Target audience

This document describes the technical implementation of CLOUD 47x0 F.

The manual targets software developers. It assumes knowledge about ISO 7816, 13.56 MHz contactless technologies like ISO/IEC 14443 and commonly used engineering terms.

Should you have questions, you may send them to support@identive-group.com.

2.3. Product version corresponding to the manual

Item	Version
Hardware	0.3
Firmware	1.00

2.4. Definition of various terms and acronyms

Term	Expansion
APDU	Application Protocol Data Unit
ATR	Answer to Reset, defined in ISO7816
ATS	Answer to select, defined in ISO/IEC 14443
Byte	Group of 8 bits
CCID	Chip Card Interface Device
CID	Card Identifier
DFU	Device Firmware Upgrade
DR	Divider receive: used to determine the baud rate between the reader to the card
DS	Divider send: used to determine the baud rate between the card to the reader
LED	Light emitting diode
MIFARE	The ISO14443 Type A with extensions for security (NXP)
NA	Not applicable
NAD	Node Address
Nibble	Group of 4 bits. 1 digit of the hexadecimal representation of a byte. <i>Example:</i> 0xA3 is represented in binary as (10100011) _b . The least significant nibble is 0x3 or (0011) _b and the most significant nibble is 0xA or (1010) _b
PCD	Proximity Coupling Device
PC/SC	Personal Computer/Smart Card: software interface to communicate between a PC and a smart card
PICC	Proximity Integrated Chip Card
PID	Product ID
Proximity	Distance coverage till ~10 cm.
PUPI	Pseudo unique PICC identifier
RF	Radio Frequency
RFU	Reserved for future use
USB	Universal Serial Bus
VID	Vendor ID
(xyz) _b	Binary notation of a number x, y, z ∈ {0,1}
0xYY	The byte value YY is represented in hexadecimal

2.5. References

Doc ref in the manual	Description	Issuer
ISO/IEC 7816-3	Identification cards — Integrated circuit cards —Part 3:Cards with contacts — Electrical interface and transmission protocols	ISO / IEC
ISO/IEC 7816-4	Identification cards - Integrated circuit(s) cards with contacts Part 4: Interindustry commands for interchange ISO/IEC 7816-4: 1995 (E)	ISO / IEC
ISO/IEC 14443-3	Identification cards — Contactless integrated circuit(s) cards — Proximity cards —Part 3:Initialization and anticollision	ISO / IEC
ISO/IEC 14443-4	Identification cards — Contactless integrated circuit(s) cards — Proximity cards Part 4: Transmission protocol ISO/IEC 14443-4:2001(E)	ISO / IEC
PC/SC	Interoperability Specification for ICCs and Personal Computer Systems v2.01	PC/SC Workgroup
PCSC3	Interoperability Specification for ICCs and Personal Computer Systems Part 3. Requirements for PC-Connected Interface Devices	PC/SC Workgroup
PCSC3-AMD1	Interoperability Specification for ICCs and Personal Computer Systems Part 3. Requirements for PC-Connected Interface Devices– Amendment 1	PC/SC Workgroup
PCSC3-SUP	Interoperability Specification for ICCs and Personal Computer Systems Part 3. Supplemental Document	PC/SC Workgroup
PCSC3-SUP2	Interoperability Specification for ICCs and Personal Computer Systems Part 3. Supplemental Document for Contactless ICCs	PC/SC Workgroup
CCID	Specification for Integrated Circuit(s) Cards Interface Devices 1.1	USB-IF
USB	Universal Serial Bus Specification 2.0	USB-IF
AN337	Application Note describing handling of DESFire EV1 cards	Identive
AN338	Application Note describing handling of MIFARE Plus cards	Identive

2.6. Conventions

Bits are represented by lower case 'b' where followed by a numbering digit.

Bytes are represented by upper case 'B' where followed by a numbering digit.

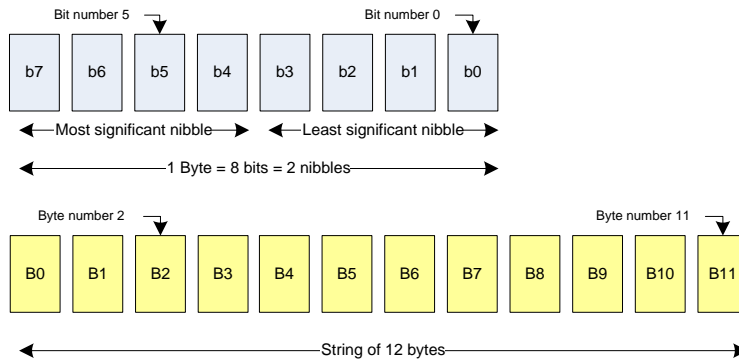

Example:

163 decimal number is represented

- in hexadecimal as 0xA3
- in binary as (10100011)b

The least significant nibble of 0xA3 is

- 0x3 in hexadecimal
- (0011)b in binary

The most significant nibble of =xA3 is

- 0xA in hexadecimal
- (1010)b in binary

3. General information about CLOUD 47x0 F

3.1. CLOUD 47x0 F key benefits



With its combination of a modern slim design and its state of the art feature set, CLOUD 4700 F is the perfect desktop reader choice for environments where both contact and contactless smart card support is required while CLOUD 4710 F perfectly fits environments where access to contactless cards with simultaneous access to a contact SAM card is required.

As for all Identive GmbH products, CLOUD 47x0 F is designed to offer best in class interoperability.

3.2. CLOUD 47x0 F key features

- 13.56MHz contactless reader:
 - ISO14443 type A & B,
 - MIFARE™
- ISO7816 compliant contact smart card reader for ID-1 cards (CLOUD 4700 F)
- ISO7816 compliant contact smart card reader for ID-000 cards (CLOUD 4710 F)
- PC/SC v2.0 compliant
- Full CCID for both the contact and the contactless interfaces
- Secure in-field SmartOS™ firmware upgrade
- Unique reader serial number which enables that CLOUD 47x0 F can be plugged into any USB slot on a PC without having to re-install the driver. Additionally, the application S/W running on the host can check for exact readers
- 249 bytes of non-volatile user memory
- Cable exit in three directions to help you place the reader optimally
- Footstand for 40° angle available that could be used as wall-mount adapter, as well

3.3. CLOUD 47x0 F ordering information

Item	Part number	
CLOUD 4700 F	905320	
CLOUD 4710 F	905324	
Standing Base Kit	905412	

3.4. Available options

The Standing Base Kit consists of a stand and a wireholder. It could be used to either place the reader on the desktop with an angle of 40° in regard to the desk or to mount it to a wall with a 40° angle in regard to that. The wireholder keeps the contactless token in place when using this option.

3.5. CLOUD 47x0 F customization options

Upon request, Identive GmbH can consider customizing:

- The color of the casing
- The logo
- The product label
- The USB strings

Terms and conditions apply, please contact your local Identive representative or send an email to sales@identive-infrastructure.com.

3.6. Contactless communication principles and CLOUD 47x0 F usage recommendations

CLOUD 47x0 F is a dual interface reader capable of reading both contact smart cards and contactless user tokens. The following paragraph focuses on a few specifics of contactless communication to outline usage recommendations in order to ensure best user experience.

CLOUD 47x0 F is a contactless reader¹ designed to communicate with user credentials.

User credentials² are made of a contactless integrated circuit chip connected to an antenna

User credentials can take several form factors:

- Credit card sized smart card
- Key fob
- USB token
- NFC mobile phone etc...

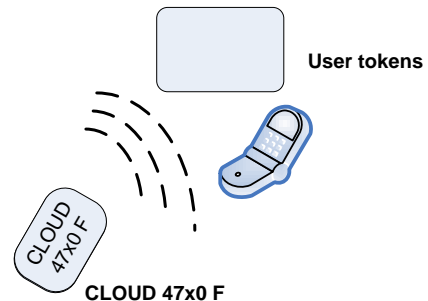

Communication between CLOUD 47x0 F and user credentials uses magnetic field inductive coupling.

The magnetic field generated by CLOUD 47x0 F has a carrier frequency of 13.56MHz.

3.6.1. Power supply

When the user credential is put in the magnetic field of the reader, its antenna couples with the reader and an induction current appears in the antenna thus providing power to the integrated circuit. The generated current is proportional to the magnetic flux going through the antenna of the user credential.

3.6.2. Data exchange

The carrier frequency of the magnetic field is used as a fundamental clock signal for the communication between the reader and the credential. It is also used as a fundamental clock input for the integrated circuit microprocessor to function.

To send data to the user credential the reader modulates the amplitude of the field. There are several amplitude modulation and data encoding rules defined in ISO/IEC 14443. The reader should refer to the standard for further details.

To answer the reader, the integrated circuit card of the user credential modulates its way of loading (impedance) the field generated by the reader. Here also further details can be found in ISO/IEC 14443.

¹ In the ISO/IEC 14443 standard, the reader is called the proximity coupling device (PCD)

² In the ISO/IEC 14443 standard, the user credential is called proximity integrated chip card (PICC)

3.6.3. Recommendations

The communication between the reader and the user credential is sensitive to the presence of material or objects interfering with the magnetic field generated by the reader.

The presence of conductive materials like metal in the vicinity of the reader and the user credential can significantly degrade the communication and even make it impossible. The magnetic field of the reader generates Eddy or Foucault's currents in the conductive materials; the field is literally absorbed by that kind of material.



It is recommended for proper communication to avoid putting CLOUD 47x0 F in close proximity of conductive materials.

The presence of multiple user credentials in the field also interferes with the communication. When several user credentials are in the field of the reader, load of the field increases which implies that less energy is available for each of them and that the system is detuned. For this reason, Identive has implemented in its driver only one slot.



It is recommended to present only one user credential at a time in front of CLOUD 47x0 F.

The communication between the reader and the credential is sensitive to the geometry of the system {reader, credential}. Parameters like the geometry and especially the relative size of the reader's and credential's antennas directly influence the inductive coupling and therefore the communication.

CLOUD 47x0 F was designed and optimized to function with user credentials of various technologies and sizes.



It may happen, that CLOUD 47x0 F is not capable of communicating with extremely large or extremely small credentials.



In order to optimize the coupling between the reader and the credential, it is recommended to put both antennas as parallel as possible to each other



In order to optimize transaction speed between the reader and the card it is recommended to place the credential as close as possible to the reader. This will increase the amount of energy supplied to the user credential which will then be able to use its microprocessor at higher speeds

3.7. Applications

3.7.1. General

CLOUD 4700 F is a transparent reader designed to interface a personal computer host supporting PC/SC interface with 13.56MHz user tokens like public transport cards, contactless banking cards, electronic identification documents – e.g. e-passports, e-ID cards, driving licenses etc. and smartcards according to ISO7816 as well as synchronous memory cards like CAC and PKI cards and health insurance cards.

User credentials can have several form factors like credit cards, key fobs, NFC mobile phones or USB dongles like our SCTxxxx or @MAXX products.

CLOUD 4710 F incorporates a SAM slot for SIM-sized cards instead of the standard card slot for ID-1 sized cards of the CLOUD 4700 F.

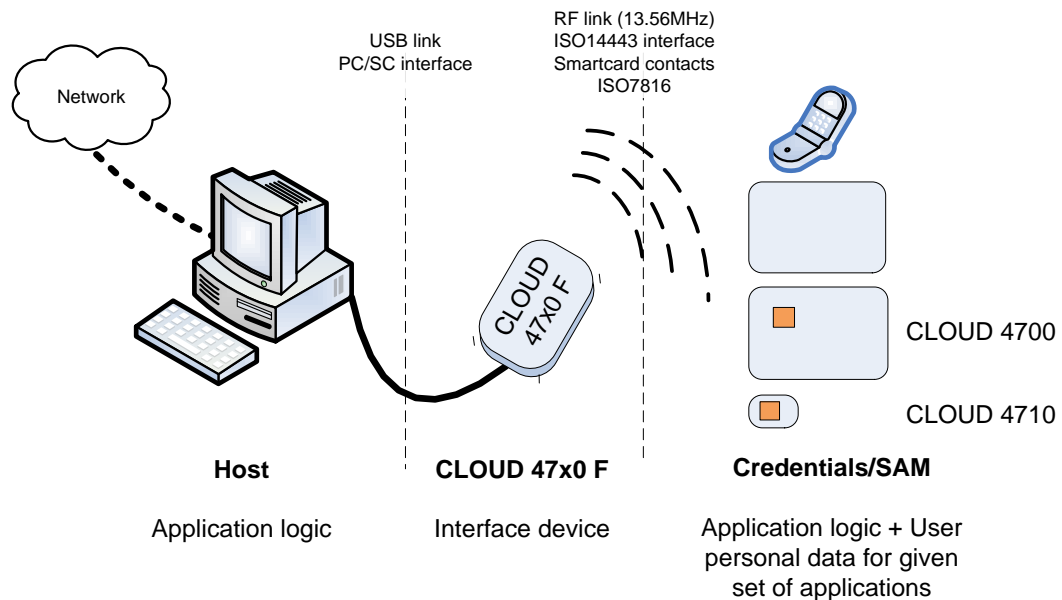

CLOUD 47x0 F itself handles the communication protocol but not the application related to the token or card. The application-specific logic has to be implemented by software developers on the host.

3.7.2. Applications provided by Identive GmbH

Identive GmbH does not provide payment or transport applications or PKI or CAC applications.

Identive GmbH provides a few applications for development and evaluation purposes that can function with CLOUD 47X0 F. There are many tools provided; here are two of them:

- The Simple NFC Tag Editor is part of our NFC-NDEF Editor Kit that enables the user to read and write NFC forum compliant records from/to NFC forum compatible tags. It is an easy to use tool to configure NFC forum tag demonstrations rapidly, available in our [web shop](#).
- Smart card commander version 1.3 provides capabilities to identify most common cards in the field and display the content of them as well as scripting functionality, which can be very useful for developers to develop and debug their applications. This tool is as well part of all our SDKs and available as a [stand-alone product](#).

4. CLOUD 47x0 F characteristics

4.1. CLOUD 47x0 F high level architecture

4.1.1. Block diagram

The link between CLOUD 47x0 F and the host to which it is connected is the USB interface providing both the power and the communication channel.

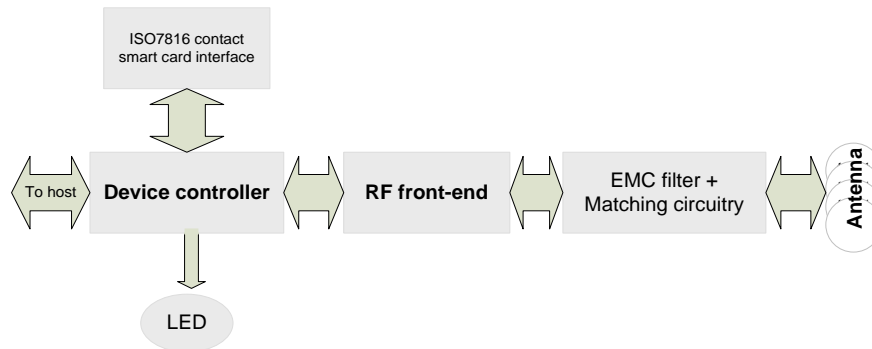

The device controller has several interfaces available. In the CLOUD 47x0 F implementation three peripherals are connected to the device controller:

- LED for reader status indication
- A contact smart card interface
- An RF front-end that handles the RF communication

The controller embeds flash memory that contains the firmware developed by Identive to handle all the ISO7816 contact protocol, the RF communication protocols and the PC/SC communication protocol with the host. The flash can be upgraded once the device is deployed in the field, hence enabling firmware upgrades to add and potentially patch features.

The RF front-end ensures the coding/decoding/framing modulation/demodulation required for the RF communication. It is controlled by the device controller through registers.

The matching circuitry provides the transmission and receiver paths adaptation for the antenna to function properly.

4.1.2. Software architecture

Applications can interface with the driver directly through the PC/SC interface.

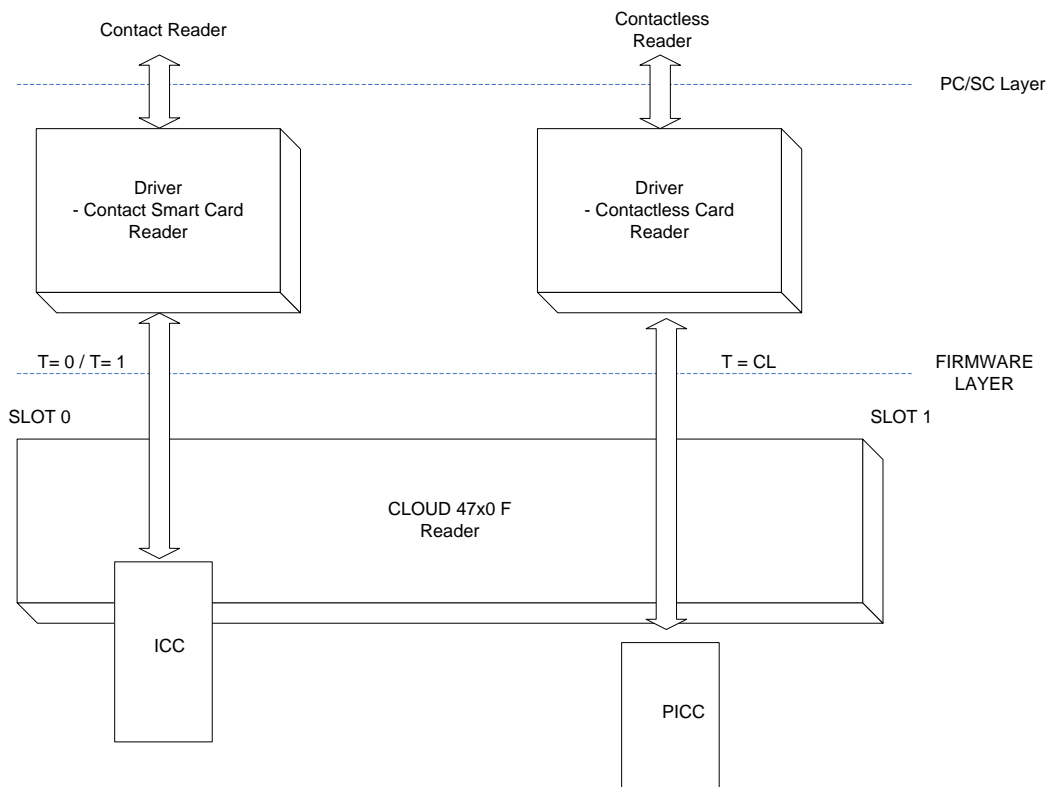

The CLOUD 47x0 F leverages a PC/SC CCID driver that is freely available for all supported operating systems (Windows, MacOSX and Linux). With current Windows versions (starting with Windows Vista) and MacOSX, this driver is already included in the basic installation.

With the diverse Linux derivatives, there may be distribution specific drivers that should get installed using the install mechanism of the used distribution.

If there is none, the driver may always be downloaded from the webpage of the maintainer, Ludovic Rousseau, https://alioth.debian.org/frs/?group_id=30105.

Additionally, Identive provides a proprietary driver for all the supported OSs.

4.2. Quick reference data

4.2.1. CLOUD 47x0 F dimensions

Item	Characteristic	Value
CLOUD 4700 F	Weight	143g without stand Stand: 52g
	External dimensions	126 mm X 93 mm X 22 mm
	Cable length	1.5 meter long with USB type A connector
	Default color	White and grey
	Default label	
CLOUD 4710 F	Weight	157g without stand Stand: 52g
	External dimensions	113 mm X 93 mm X 22 mm
	Cable length	1.5 meter long with USB type A connector
	Default color	White and grey
	Default label	

Drawing with dimensions of the CLOUD 47X0 F and accessories can be found in annex.

4.2.2. LED behavior

CLOUD 47X0 F is equipped with one bicolor LED. Its behavior is described in the table below.

Reader states	GREEN	RED
Just after plug-in (with drivers already installed)	ON	OFF
Just after DFU operation	ON	OFF
Suspend / standby	OFF	OFF
Reader powered, Contact card IN, but not powered	ON	OFF
Reader powered, Contactless card IN, but not powered	ON	ON
Contact card powered / communication	500ms ON 500ms OFF	OFF
Contactless card powered / communication	500ms ON 500ms OFF	500ms ON 500ms OFF
Reader / card errors	OFF	100ms ON 100ms OFF
Dual interface card powered in contact Slot	500ms ON 500ms OFF	OFF
Dual interface card powered using RF field	500ms ON 500ms OFF	500ms ON 500ms OFF

4.2.3. Other data

4.2.3.1. General

Parameter	Value/Description
Clock of the device controller	8MHz
API	PC/SC 2.0
Operating temperature range	0° to 50°C
Operating humidity range	Up to 95%RH non condensing
Certifications	USB CE FCC WEEE RoHS2 REACH WHQL

4.2.3.2. USB

Parameter	Value/Description
DC characteristics	High bus powered (CLOUD 47x0 F draws power from USB bus) Voltage: 5V Avg.. Current : 110mA (RF on, no cards present) Suspend Current: 400µA
USB specification	USB 2.0 FS Device
USB Speed	Full Speed Device (12Mbit/s)
Device Class	CCID
PID	0x5720
VID	0x04E6

4.2.3.3. Contact card interface

Parameter	Value/Description
Smart card operating frequency	up to 12MHz
Maximum supported card baud-rate	600Kbps
Cards supported	ISO/IEC 7816 smart cards - Class A, B and C Synchronous smart cards
ISO-7816 compliant	Yes
CT-API compliant	Yes
Number of slots	Single smart card slot
Ejection mechanism	Manual

4.2.3.4. Contactless interface

Parameter	Value/Description
RF carrier frequency	13.56MHz +/-50ppm
Maximum supported card baud-rate	848Kbps
Cards supported	<ul style="list-style-type: none"> • MIFARE: Classic 1K and 4K, DESFire, DESFire EV1, Ultralight, Ultralight C, MIFARE mini and MIFARE Plus • FeliCa™ 212 and 424 Kbps support: FeliCa Standard/Lite • NFC forum tag type 1, 2, 3, 4 • iCLASS UID support • my-d move – SLE 66RxxP, my-d move NFC – SLE 66RxxPN, SLE 66RxxS, SLE 55RxxE • NFC enabled Smart Phones and Tablets³
ISO-14443A and B compliant	Yes
Number of slots	1
Ejection mechanism	Manual

³ tested with available device during development & qualification phase

5. Software modules

5.1. Installation

On Operating Systems with a CCID driver pre-installed, no installation is necessary.

Where there's no CCID driver pre-installed – e.g. Linux systems or old Windows systems – the driver has to be installed using distribution-specific measures or using the available source packages.

Nevertheless, due to some limitations of the available CCID drivers under some circumstances, Identive does provide a dedicated driver for this reader, as well, which is available through Windows Update or on the [Identive support pages](#).

5.2. Utilities

The following utilities are available:

- A tool for testing the resource manager
- A tool called *PCSCDiag* capable of providing basic information about the reader and a card through PC/SC stack

5.3. Driver

5.3.1. CLOUD 47x0 F listing

CLOUD 47X0 F is listed by PC/SC applications as

- *Identive CLOUD 47X0 F Contact Reader*
- *Identive CLOUD 47X0 F Contactless Reader*

5.3.2. Supported operating systems

- Windows XP (32 & 64 bit)
- Windows 2003 Server (32 & 64 bit)
- Windows Vista (32 & 64 bit)
- Windows Server 2008 (32 & 64 bit)
- Windows 7 (32 & 64 bit)
- Windows 8 (32 & 64 bit)
- MacOS X
- Linux

5.3.3. PC/SC 2.0 compliant ATR for contactless interface

When a user credential is placed on the reader, initialization, anti-collision is done. The user credential is automatically activated and an ATR is built as defined in the PC/SC specification. For further information, please refer to section 3.1.3.2.3 of [PCSC3] and to [PCSC3-SUP]

5.3.3.1. ATR for contactless storage user tokens

The ATR of the credential is composed as described in the table below. In order to allow the application to identify the storage card properly, it's Standard and Card name describing bytes must be interpreted according to the Part 3 Supplemental Document, maintained by PC/SC.

Credentials using technology like MIFARE are examples of this:

Byte#	Value	Designation	Description
0	0x3B	Initial header	
1	0x8n	T0	n indicates the number of historical bytes in following ATR
2	0x80	TD1	upper nibble 8 indicates no TA2, TB2, TC2 lower nibble 0 means T=0
3	0x01	TD2	upper nibble 0 indicates no TA3, TB3, TC3 lower nibble 1 means T=1
4...3+n	0x80		A status indicator may be present in an optional TLV data object
	0x4F	Optional TLV data object	Tag: Application identifier
	Length		1 byte
	RID		Registered identifier on 5 bytes
	PIX		Proprietary identifier extension on 3 bytes
0x00 0x000x000x00	4 RFU bytes		
4+n		TCK	XOR of all previous bytes

Example of the ATR built for contactless storage tokens:

MIFARE Classic 4K

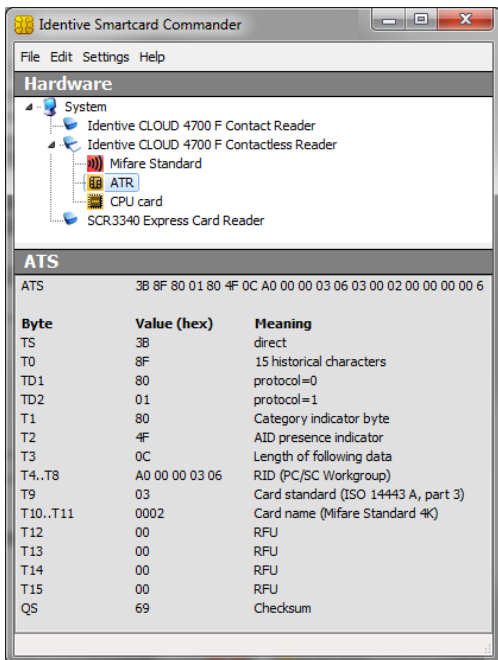

MIFARE Ultralight

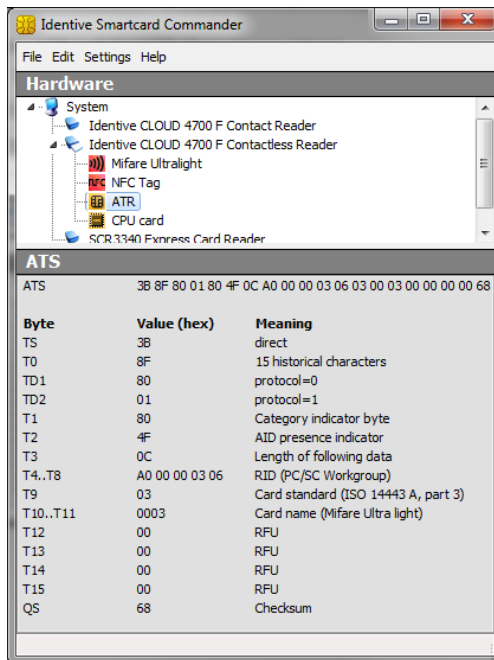

5.3.3.2. ATR for ISO/IEC 14443-4 user tokens

The credential exposes its ATS or application information which is mapped to an ATR. The table describes how this mapping is done.

Byte#	Value	Designation	Description
0	0x3B	Initial header	
1	0x8n	T0	n indicates the number of historical bytes in following ATR
2	0x80	TD1	upper nibble 8 indicates no TA2, TB2, TC2 lower nibble 0 means T=0
3	0x01	TD2	upper nibble 0 indicates no TA3, TB3, TC3 lower nibble 1 means T=1
4...3+n		Historical bytes or application information	Type A: the historical bytes from the ATS (up to 15 bytes) Type B (8 bytes): <ul style="list-style-type: none"> Byte 0 through 3: application data from ATQB, Byte 4 through 6: protocol info byte from ATQB, Byte 7: highest nibble is the MBLI (maximum buffer length index) from ATTRIB, lowest nibble is 0x0
4+n		TCK	XOR of all previous bytes

Example of the ATR built for an ISO14443-4 credential:

Type A

Type B

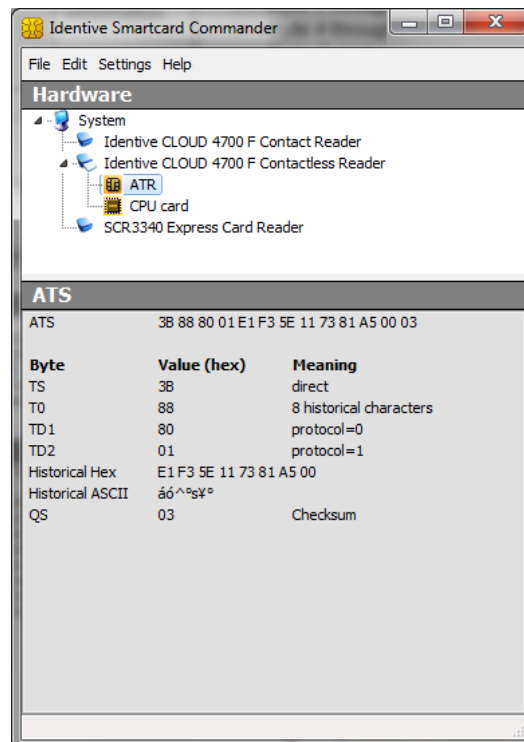
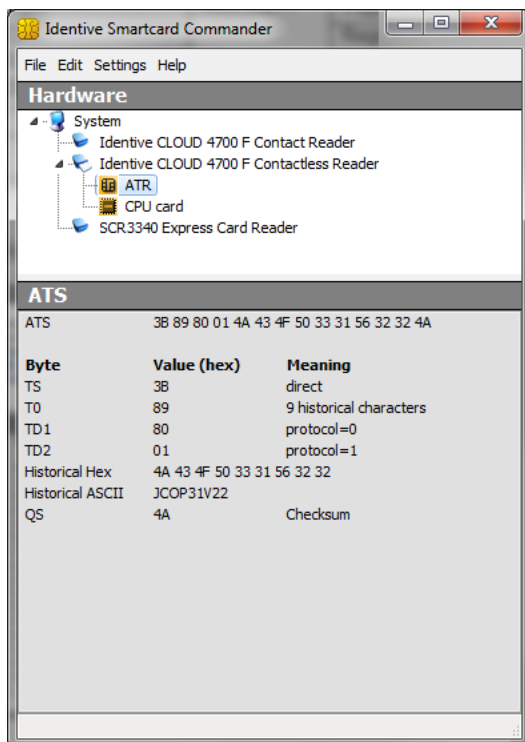

5.4. Firmware

5.4.1. CCID transport protocol

CLOUD 47x0 F implements a transport protocol that is compliant with USB Device Class: *Smart Card CCID Specification for Integrated Circuit(s) Cards Interface Devices Revision 1.10*.

This paragraph describes the CCID specification features that are implemented.

5.4.1.1. CCID class requests supported

- Abort

5.4.1.2. CCID messages supported

The following CCID messages are supported for the contact interface when received through bulk-out endpoint.

- PC_to_RDR_IccPowerOn
- PC_to_RDR_IccPowerOff
- PC_to_RDR_GetSlotStatus
- PC_to_RDR_XfrBlock
- PC_to_RDR_GetParameters
- PC_to_RDR_ResetParameters
- PC_to_RDR_SetParameters
- PC_to_RDR_Escape
- PC_to_RDR_ICCClock
- PC_to_RDR_T0APDU
- PC_to_RDR_Abort
- PC_to_RDR_SetDataRateAndClockFrequency

5.4.1.3. CCID Error Codes

Extensive error codes are reported on many conditions during all CCID responses. Most of the error messages are reported by the CCID appropriately. Some of the main error codes for the contact interface are:

- HW_ERROR
- XFR_PARITY_ERROR
- ICC_PROTOCOL_NOT_SUPPORTED
- BAD_ATR_TS
- BAD_ATR_TCK
- ICC_MUTE
- CMD_ABORTED
- Command not supported

The following sub-sections discuss when and why these error codes are returned:

5.4.1.3.1. HW_ERROR

This error code is returned when a hardware short circuit condition is detected, during application of power to the card or if any other internal hardware error is detected.

5.4.1.3.2. XFR_PARITY_ERROR

This error code is returned when a parity error condition is detected. This error will be reported in the response to a PC_to_RDR_XfrBlock message.

5.4.1.3.3. ICC_PROTOCOL_NOT_SUPPORTED

This error code is returned if the card is signaling to use a protocol other than T=0 or T=1 in its ATR.

5.4.1.3.4. BAD_ATR_TS

This error code is returned if the initial character of the ATR contains invalid data.

5.4.1.3.5. BAD_ATR_TCK

This error code is returned if the check character of the ATR contains is invalid.

5.4.1.3.6. ICC_MUTE

This error code is returned when the card does not respond until the reader time out occurs. This error will be reported in the response to PC_to_RDR_XfrBlock message and PC_to_RDR_IccPowerOn messages.

5.4.1.3.7. CMD_ABORTED

This error code is returned if the command issued has been aborted by the control pipe.

5.4.1.3.8. Command not supported

This error would be returned, if the command would not be supported by the reader.

6. Commands description

6.1. Generic APDU

6.1.1. Working with DESFire and MIFARE Plus tokens

To work with DESFire EV1 and MIFARE Plus tokens, please refer to the according application notes [AN337] and [AN338], respectively.

Please note that, since these application notes contain information available only under NDA with NXP, you'd need to sign an NDA with NXP to be allowed to receive them.

6.1.2. PAPDU_GET_UID

GET UID will retrieve the UID or SNR or PUPI of the user token. This command can be used for all supported technologies.

Command APDU:

CLA	INS	P1	P2	Lc	Data in	Le
0xFF	0xCA	0x00	0x00	-	-	XX

Setting Le = 0x00 can be used to request the full UID or PUPI is sent back. (e.g. for ISO14443A single 4 bytes, double 7 bytes, triple 10 bytes, for ISO14443B 4 bytes PUPI).

Response APDU:

Data	Status Word
Requested bytes of UID	SW1, SW2

6.1.3. PAPDU_ESCAPE_CMD

Usually escape commands are transmitted through SCardControl as defined in PCSC API using IOCTL_CCID_ESCAPE. But on some environments, the driver will block this IOCTL unless the registry has been edited to allow it. Hence this vendor specific APDU was defined to transmit Escape commands to the reader as below

Command APDU:

CLA	INS	P1	P2	Lc	Data in	Le
0xFF	0xCC	0x00	0x00	Length of data	Escape Command Buffer	XX

Response APDU:

Data	Status Word
Reader Response	SW1, SW2

Example:

- 1) To issue the "READER_GETIFDTYPE (0x12)" escape command , this pseudo APDU would be used:

Command APDU : FF CC 00 00 01 12
Response : 20 57 90 00

- 2) To issue the "READER_SETMODE (0X01)" escape command, this pseudo APDU would be used:

Command APDU : FF CC 00 00 02 01 01 (to set to EMV mode)
Response APDU : 90 00

Note:

- 1) To send Escape commands using this method, the reader should be connected in shared mode using T0 or T1 protocol. Only then would the resource manager allow SCardTransmit.
- 2) As the escape commands defined using "[READER_GENERIC_ESCAPE](#)" have ISO 7816 APDU format, they can be sent using SCardTransmit without having any need to prepend "FF CC 00 00 P3".

6.2. Supported Pseudo APDU (Contactless Interface)

All Pseudo APDUs specific to Contactless Interface supported in the reader are explained in this section

6.2.1. PAPDU_MIFARE_READ_BINARY

This command is used to read data from a Mifare card. Refer to section 3.2.2.1.8 of [PCSC3] for details.

Command APDU:

Command	CLA	INS	P1	P2	Lc	Data	Le
Read Binary	0xFF	0xB0	Addr MSB	Addr LSB	-	-	xx

P1 and P2 represent the block number of the block to be read, starting with 0 for sector 0, block 0, continuing with 4 for sector 1, block 0 (sector no. x 4 + block no.)

Regardless of the value given in Le, this command will always return the entire block content:
 16 bytes for Mifare Classic
 4 bytes for Mifare UL and UL C

Response APDU:

Data	Status Word
N bytes of block data	SW1, SW2

Example:

For a Mifare Classic 1K card with the following content:

Mifare Standard													
Card type: Mifare Standard													
Memory size: 1024 Bytes													
Unique ID: 1A E3 B3 39													
Sector	Hex	ASCII								Block Read	Block Write	Block Inc	Block Dec
0	1AE3 B339 7388 0400 47C1 25A8 4100 3106	.ä³9sˆ..GÄªA.1.								A B	A B	A B	A
	0000 0000 0000 0000 0000 0000 0000 0000								A B	A B	A B	A
	0000 0000 0000 0000 0000 0000 0000 0000								A B	A B	A B	A
	FFFF FFFF FFFF FF07 8069 FFFF FFFF FFFF	yyyyyyyy.€iyyyyyy											
1	0000 0000 0000 0000 0000 0000 0000 0000								A B	A B	A B	A
	0001 0203 0405 0607 0809 0A0B 0C0D 0E0F								A B	A B	A B	A
	0000 0000 0000 0000 0000 0000 0000 0000								A B	A B	A B	A
	FFFF FFFF FFFF FF07 8069 FFFF FFFF FFFF	yyyyyyyy.€iyyyyyy											

The following command will read the sixth block and yield the mentioned output:

```
APDU: FF B0 00 05 02
SW12: 9000 (OK)
DataOut: 00 01 02 03 04 05 06 07 08 09 0A 0B 0C 0D 0E 0F (16 bytes)
```

6.2.2. PAPDU_MIFARE_UPDATE_BINARY

This command is used to update the non-volatile memory of a Mifare card. Refer to section 3.2.2.1.9 of [PCSC3] for further details.

Command APDU:

Command	CLA	INS	P1	P2	Lc	Data	Le
Update Binary	0xFF	0xD6	Addr MSB	Addr LSB	xx	data	-

For a description of P1 and P2, see [PAPDU_MIFARE_READ_BINARY](#)

Lc has got to match the block size of the used card
 16 bytes for Mifare Classic
 4 bytes for Mifare UL and UL C

Response APDU:

Data	Status Word
-	SW1, SW2

Example:

To write the bytes AA 55 AA 55 AA 55 AA 55 AA 55 AA 55 AA 55 AA 55 AA 55 to block 7 of a Mifare Classic 1K, the following command has got to be issued:

```
APDU: FF D6 00 06 10 AA 55 AA 55 AA 55 AA 55 AA 55 AA 55 AA 55 AA 55 AA 55
SW12: 9000 (OK)
```

Resulting in this content on the card:

Mifare Standard														
Card type: Mifare Standard														
Memory size: 1024 Bytes														
Unique ID: 1A E3 B3 39														
Sector	Hex	Hex							ASCII	Block Read	Block Write	Block Inc	Block Dec	
0	1AE3	B339	7388	0400	47C1	25A8	4100	3106	.ã°9s^..GÁ°~A.1.	A B	A B	A B	A	▲
	0000	0000	0000	0000	0000	0000	0000	0000	A B	A B	A B	A	□
	0000	0000	0000	0000	0000	0000	0000	0000	A B	A B	A B	A	
	FFFF	FFFF	FFFF	FF07	8069	FFFF	FFFF	FFFF	YYYYYYY.€iYYYYYY					
1	0000	0000	0000	0000	0000	0000	0000	0000	A B	A B	A B	A	
	0001	0203	0405	0607	0809	0A0B	0C0D	0E0F	A B	A B	A B	A	
	AA55	AA55	AA55	AA55	AA55	AA55	AA55	AA55	°U°U°U°U°U°U°U°U	A B	A B	A B	A	
	FFFF	FFFF	FFFF	FF07	8069	FFFF	FFFF	FFFF	YYYYYYY.€iYYYYYY					

6.2.3. PAPDU_MIFARE_LOAD_KEYS

This command is used to load the key to the volatile memory of the reader. It can be used for all kinds of contactless cards. Refer to section 3.2.2.1.4 of [PCSC3] for further details.

Command APDU:

Command	CLA	INS	P1	P2	Lc	Data	Le
Load Keys	0xFF	0x82	Key Struct	Key Num	Key data	Key	-

The Key Structure (P1) is defined as follows:

b7	b6	b5	b4	b3	b2	b1	b0	Description
x								0: Card Key; 1 Reader Key
	x							0: Plain Transmission, 1: Secured Transmission
		x						0: Keys are loaded into the volatile memory 1: Keys are loaded into the non-volatile memory.
			x					RFU
				xxxx				If b6 is set, it is the Reader Key number that has been used for the encryption, else it is ignored. Only one reader key (0x00) is supported by CLOUD 47x0 F

Notes:

- 1) Card keys can be loaded in both “secure” and “non-secure” mode. Card keys can only be loaded to the Volatile memory of the reader.
- 2) To load the card keys in secure mode, the application developer has to know the 128 bit AES key of the reader. The default key is “00010203 05060708 0A0B0C0D 0F101112”.
As a Mifare key is only 6 bytes in length, data needs to be padded as per pkcs7 padding scheme (see example below).
- 3) The Reader-key can only be loaded in the secure-mode to the non-volatile memory of the reader. The new key is first XORed with the old key and encrypted with the old key. In order to validate the integrity of the processed key data, a 2 byte CRC has got to be sent following the key data. Refer to the example [Load Keys – Reader – Secure](#) for details.
- 4) The CRC16 is calculated as defined in CRC-16-CCITT (polynomial 0x8408) with an initial value of 0x0000.

Response APDU:

Data	Status Word
-	SW1, SW2

Examples

Load Keys – Card – Non-Secure

The command to load Mifare key A “FF FFFFFFFF” is

```
FF82006006 FFFFFFFF
```

Load Keys – Card – Secure:

If the default AES128 reader is key is 00010203 05060708 0A0B0C0D 0F101112 then the following explains the steps needed to calculate the key for secure mode.

```
Default reader key      : 00010203 05060708 0A0B0C0D 0F101112
Mifare Key to be loaded : FFFFFFFF FFFF
Mifare key after padding : FFFFFFFF FFFF0A0A 0A0A0A0A 0A0A0A0A
AES128 Encrypted       : 10229E33 189403FD A9C14110 B1BB02B4
Load keys command      : FF82406010 10229E33 189403FD A9C14110 B1BB02B4
```

Load Keys – Reader – Secure

If the default AES128 reader is key is 00010203 05060708 0A0B0C0D 0F101112 then the following explains the steps needed to change the reader key to 10111213 15161718 1A1B1C1D 1F202122.

```
Reader old-key         : A: 00010203 05060708 0A0B0C0D 0F101112
Reader new-key         : B: 10111213 15161718 1A1B1C1D 1F202122
C = XOR (A,B)         : C: 10101010 10101010 10101010 10303030
D = CRC16 (C)         : D: 1C5F
E = 0x00 - D          : E: E3A1 (should be appended in LSB order)
F = AES-Encrypt (C)   : F: 886B0872 7BDA4996 D296FB46 09D2C75F
Load-Keys Command     : G: FF82E00012 886B0872 7BDA4996 D296FB46 09D2C75F A1E3
```

6.2.4. PAPDU_MIFARE_AUTHENTICATE

This command is used to authenticate using the key number. Refer to section 3.2.2.1.6 of [PCSC3] for further details.

Command APDU:

Command	CLA	INS	P1	P2	Lc	Data	Le
General Authenticate	0xFF	0x86	0x00	0x00	0x05	data	xx

the data structure is defined as follows:

Byte #	Value	Description
B0	0x01	Version
B1		Block Number MSB (always 0x00 for Mifare Classic cards)
B2		Block Number LSB
B3	0x60	Mifare Classic Key A
	0x61	Mifare Classic Key B
B4		Key number – shall be set to 0x01

Response APDU:

Data	Status Word
-	SW1, SW2

Example:

Load Key A unencrypted and authenticate for block 6 (sector 1, actually) with that key:

```
APDU: FF 82 00 60 06 FF FF FF FF FF FF
SW12: 9000 (OK)
APDU: FF 86 00 00 05 01 00 06 60 01
SW12: 9000 (OK)
```

6.2.5. PAPDU_MIFARE_READ_SECTOR

This command reads the specified sector from a Mifare Classic card (first 3 blocks of the sector, excluding the Key block) or the entire content of Mifare UL/UL C cards.

Command APDU:

Command	CLA	INS	P1	P2	P3	Data
Read Sector	FF	B1	Addr MSB	Addr LSB	0	-

Response APDU:

Data	Status Word
Mifare classic - 48 bytes of sector data read from card / Mifare UL – Entire card data is returned (64 bytes)	SW1, SW2

Example:

Read sector 1 of a Mifare Classic 1K

```

APDU: FF B1 00 01 00
SW12: 9000 (OK)
DataOut: 00 00 00 00 00 00 00 00 00 00 00 00 00 00 00 00 00
00 01 02 03 04 05 06 07 08 09 0A 0B 0C 0D 0E 0F
AA 55 AA 55 AA 55 AA 55 AA 55 AA 55 AA 55 AA 55 AA 55 (48 bytes)
    
```

Read entire content of a Mifare UL:

```

APDU: FF B1 00 01 10
SW12: 9000 (OK)
DataOut: 04 6B 5D BA 09 F8 01 80 70 48 00 00 E1 10 06 00
00 01 02 03 1D 6E 6F 6B 69 61 2E 63 6F 6D 3A 62
74 01 00 11 67 9F 5F B6 04 06 80 30 30 30 30 00
00 00 00 00 00 00 00 00 00 00 00 02 42 54 FE 00 (64 bytes)
    
```

6.2.6. PAPDU_MIFARE_READ_SECTOR_EX

This command read the specified sector from a Mifare Classic card (all the 4 blocks of the sector, including the Key block) or the entire content of Mifare UL/UL C cards.

Command APDU:

Command	CLA	INS	P1	P2	P3	Data
Read Sector Extended	FF	B3	Addr MSB	Addr LSB	0	-

Response APDU:

Data	Status Word
Mifare classic - 64 bytes of sector data read from card / Mifare UL – Entire card data is returned (64 bytes)	SW1, SW2

Example:

Read sector 1 of a Mifare Classic 1K

APDU: **FF B3 00 01 10**

SW12: **9000 (OK)**

DataOut: 00 00 00 00 00 00 00 00 00 00 00 00 00 00 00 00 00

00 01 02 03 04 05 06 07 08 09 0A 0B 0C 0D 0E 0F

AA 55 AA 55 AA 55 AA 55 AA 55 AA 55 AA 55 AA 55

00 00 00 00 00 00 FF 07 80 69 FF FF FF FF FF FF (64 bytes)

6.2.7. PAPDU_MIFARE_WRITE_SECTOR

This command writes the contained data to the specified sector of a Mifare classic or Mifare UL/UL C card (first blocks of the sector, excluding the Key block are written in case of Mifare Classic).

Command APDU:

Command	CLA	INS	P1	P2	P3	Data
Write Sector	FF	D7	AddrMsb	AddrLsb	Lc	Data

Lc (P3) has got to be 0x30 when writing to the small sectors of a Mifare Classic and 0xF0 when writing to the large sectors of a Mifare Classic 4K.

Lc has got to be 0x30 for Mifare UL and the data will get written from block 4 till the end of the memory.

Response APDU:

Data	Status Word
-	SW1, SW2

6.2.8. PAPDU_MIFARE_VALUE_BLK_OLD

This command increments or decrements the data in a Value Block on a Mifare Classic card.

Command APDU:

Command	CLA	INS	P1	P2	P3	Data
Increment/ Decrement OLD	FF	F0	00	Block Num	Lc	Data

where P2 codes the block number.

The data field is structured as follows

Byte #	Value	Description
B0	0xC0	Decrement
	0xC1	Increment
B1		Block number
B2-B5		Value (LSB first)

Response APDU:

Data	Status Word
-	SW1, SW2

Example: decrement block 4 by 1 (key loading and authentication not shown)

(block 4 has got to be set up as value block prior to executing this command, see datasheet for Mifare Classic cards)

APDU: **FF B0 00 04 00 // Read Block 4**

SW12: **9000 (OK)**

DataOut: **A9 AA AA AA 56 55 55 55 A9 AA AA AA 05 FA 05 FA** (16 bytes)

APDU: **FF F0 00 04 06 C0 04 01 00 00 00 // decrement block 4 by 1**

SW12: **9000 (OK)**

APDU: **FF B0 00 04 00 // Read Block 4**

SW12: **9000 (OK)**

DataOut: **A8 AA AA AA 57 55 55 55 A8 AA AA AA 05 FA 05 FA** (16 bytes)

6.2.9. PAPDU_MIFARE_VALUE_BLK_NEW

This command increments or decrements the value of a data object if the card supports it. Refer to section 3.2.2.1.10 of [PCSC3-AMD1] for further details.

Command APDU:

Command	CLA	INS	P1	P2	Lc	Data	Le
Increment/ Decrement	FF	C2	00	03	xx	BER- TLV	00

The data object consists of a TLV structure that defines, which action should be performed, which block the actions pertain to (the destination(s)) and which value should be applied for the action.

Tags for the action include:

- 0xA0: Increment
- 0xA1: Decrement

The Tag to define the destination is:

- 0x80: Destination

The Tag to define the value is:

- 0x81: value to increment or decrement Destination by, LSB first

Example:

Increment block 5 by 100

```
FF C2 00 03 0B
A0 09                increment
80 01 05            block 5
81 04 64 00 00 00 by 100
                   00
```

This command returns a Response APDU according to section 2.2 of [PCSC3-SUP2].

Response APDU:

Data	Status Word
C0 03 Error status, see below	SW1, SW2 (card itself will send SW1, SW2)

Error Status	Description
XX SW1 SW2	XX = number of the bad data object in the APDU; 00 = general error of APDU; 01 = error in the 1 st data object; 02 = error in the 2 nd data object; etc.
00 90 00	No error occurred
XX 62 82	Data object XX warning, requested information not available
XX 63 00	No information.
XX 63 01	Execution stopped due to failure in other data object
XX 6A 81	Data object XX not supported
XX 67 00	Data object XX with unexpected length
XX 6A 80	Data object XX with unexpected value
XX 64 00	Data Object XX execution error (no response from IFD)
XX 64 01	Data Object XX execution error (no response from ICC)
XX 6F 00	Data object XX failed, no precise diagnosis

6.2.10. PAPDU_TCL_PASS_THRU (T=CL Pass Thru)

This command can be used to send raw data using T=CL protocol to a card. Please refer to the status words defined by the PICC manufacturer for a description of the status words

Command APDU:

Command	CLA	INS	P1	P2	P3	Data
Pass-through	FF	FE	00	00	Lc	Data

Response APDU:

Data	Status Word
PICC response data	SW1, SW2 (card itself will send SW1, SW2)

6.2.11. PAPDU_ISO14443_PART3_PASS_THRU (Mifare Pass Thru)

This command is used to send raw data using Type A standard framing to a card. CRC bytes will be appended automatically. The reader will not add transport protocol data to the raw data – e.g. PCB, NAD, CID etc.

Command APDU:

Command	CLA	INS	P1	P2	P3	Data
Part 3 Pass-through	FF	EF	Transmit CRC	00	Lc	Data

P1 = 0x00 will transmit the CRC bytes from the card as is to the application.
P1 = 0x01 will discard the CRC bytes.

Response APDU:

Data	Status Word
Data returned by card	SW1, SW2

6.2.12. PAPDU_ISO14443_PART4_PART3_SWITCH (TCL – Mifare Switch)

This command switches the card state between TCL and MIFARE modes

Command APDU:

Command	CLA	INS	P1	P2	P3	Data
Part 4-Part 3 Switch	FF	F8	P1	00	00	-

P1 = 0x00 switches from MIFARE mode to TCL mode
P1 = 0x01 switches from TCL mode to MIFARE mode

Response APDU:

Data	Status Word
-	SW1, SW2

NOTE: This command is mainly targeted at Mifare plus S0 cards. Mifare plus card at S0 level get detected as Mifare memory card. In order to personalize these cards first it needs to be switched to Part 4 mode. For this purpose this user command needs to be issued using SCardTransmit function.

6.2.13. PAPDU_FELICA_REQC

This command Issues REQC as defined in JIS 7.5.1. It is used to detect the presence of a NFC Forum tag type 3 in the field

Command APDU:

Command	CLA	INS	P1	P2	P3	Data
FeliCa REQC	FF	40	00	00	04	2 bytes of system code, 1 byte RFU, 1 byte TSN

Response APDU:

Data	Status Word
16 bytes of NFCID2 + 2 bytes of System Code (sent only if the RFU byte is 0x01)	SW1, SW2

6.2.14. PAPDU_FELICA_REQ_SERVICE

This command issues a REQ SERVICE as defined in JIS 9.6.2. P1. On receiving this command an NFC Forum tag type 3 will respond with the area key version of the specified area and the service key version of the specified service.

Command APDU:

Command	CLA	INS	P1	P2	P3	Data
FeliCa REQ Service	FF	42	Number of services/areas	00	2 * P1	Service Code List / Area Code List

Response APDU:

Data	Status Word
8 bytes IDm + No. of Service or areas(n) + Service version or area version list (2*n)	SW1, SW2

6.2.15. PAPDU_FELICA_REQ_RESPONSE

This command issues a REQ RESPONSE as defined in JIS 9.6.1. When an NFC Forum tag type 3 receives this command, it responds with its current mode (0/1/2).

Command APDU:

Command	CLA	INS	P1	P2	P3	Data
FeliCa REQ Response	FF	44	00	00	00	-

Response APDU:

Data	Status Word
8 bytes IDm + Mode	SW1, SW2

6.2.16. PAPDU_FELICA_READ_BLK

This command issues a READ as defined in JIS 9.6.3

- P1 specifies the number of service
- P2 specifies the number of blocks
- Data buffer specifies the service code and block list

When an NFC Forum tag type 3 receives this command, it responds with the record value of the specified service.

Command APDU:

Command	CLA	INS	P1	P2	P3	Data
FeliCa REQ Response	FF	46	Number of service	Number of blocks	$2 \times (P1 + P2)$	Service Code List, Block List

Response APDU:

Data	Status Word
8 bytes IDm + Status Flag 1 + Status Flag 2 + No. of blocks(n) + Block data (n*16)	SW1, SW2

6.2.17. PAPDU_FELICA_WRITE_BLK

This command issues a WRITE as defined in JIS 9.6.4

- P1 specifies the number of service
- P2 specifies the number of blocks

When an NFC Forum tag type 3 receives this command, it writes the records of the specified service.

Command APDU:

Command	CLA	INS	P1	P2	P3	Data
FeliCa Write Block	0xFF	0x48	Number of service	Number of blocks	$2 \times (P1 + P2) + (16 \times P2)$	Service Code List, Block List, Block Data

Response APDU:

Data	Status Word
8 bytes IDm + Status Flag 1 + Status Flag 2	SW1, SW2

6.2.18. PAPDU_FELICA_SYS_CODE

This command issues a REQ SYSTEM CODE as defined in RC-S850 / 860 Command-Ref-Manual Section 6.1.7

Command APDU:

Command	CLA	INS	P1	P2	P3	Data
FeliCa REQ SYSTEM CODE	FF	4A	00	00	00	-

Response APDU:

Data	Status Word
8 bytes IDm + No. of System Codes (n) + System Code List (2n)	SW1, SW2

6.2.19. PAPDU_NFC_TYPE1_TAG_RID

This command issues a RID to get the tag's identification data.

Command APDU:

Command	CLA	INS	P1	P2	P3	Data
TYPE1 Tag RID	FF	50	00	00	00	-

Response APDU:

Data	Status Word
HR0 HR1 UID0 UID1 UID2 UID3	SW1, SW2

Where

- HR0 and HR1 are the 2 bytes Header ROM which identify the tag
- UID0 through UID3 are the first 3 bytes of the tag's UID.

Topaz tags have a 7 bytes long UID which can be fully fetched using the [GET_UID APDU](#) described earlier in this manual.

6.2.20. PAPDU_NFC_TYPE1_TAG_RALL

This command issues a RALL to read the two header ROM bytes and the whole of the static memory blocks 0x0-0xE.

Command APDU:

Command	CLA	INS	P1	P2	P3	Data
TYPE1 Tag RALL	FF	52	00	00	00	-

Response APDU:

Data	Status Word
HR0 HR1 120 bytes (Blocks 0 – E)	SW1, SW2

6.2.21. PAPERDU_NFC_TYPE1_TAG_READ

This command issues a READ to read a single EEPROM memory byte within the static memory model area of blocks 0x0-0xE.

Command APDU:

Command	CLA	INS	P1	P2	P3	Data
TYPE1 Tag READ	FF	54	00	Byte Addr	00	-

Where P2 codes the address of the memory byte in the following way:

Bit numbers	Description
b7 – b3	Block # (value between 0x0 and 0xE)
b2 – b0	Byte # within the block (value between 0 and 7)

Response APDU:

Data	Status Word
Data returned by card	SW1, SW2

6.2.22. PAPERDU_NFC_TYPE1_TAG_WRITE_E

This command issues a WRITE to erase and then write the value of 1 memory byte within the static memory model area of blocks 0x0-0xE.

Command APDU:

Command	CLA	INS	P1	P2	P3	Data
TYPE1 Tag WRITE ERASE	FF	56	00	Byte Addr	01	Data

Where P2 codes the address of the memory byte in the following way:

Bit numbers	Description
b7 – b3	Block # (value between 0x0 and 0xE)
b2 – b0	Byte # within the block (value between 0 and 7)

Response APDU:

Data	Status Word
Data returned by card	SW1, SW2

6.2.23. PAPDU_NFC_TYPE1_TAG_WRITE_NE

This command issues a WRITE-NE to write a byte value to one byte within the static memory model area of blocks 0x0-0xE. It does not erase the value of the targeted byte before writing the new data. Execution time of this command for NFC Forum tags type 1 is approximately half that of the normal write command (WRITE-E). Using this command, EEPROM bits can only be set, not reset.

Command APDU:

Command	CLA	INS	P1	P2	P3	Data
TYPE1 Tag WRITE No ERASE	FF	58	00	Byte Addr	01	Data

Where P2 codes the address of the memory byte in the following way:

Bit numbers	Description
b7 – b3	Block # (value between 0x0 and 0xE)
b2 – b0	Byte # within the block (value between 0 and 7)

Response APDU:

Data	Status Word
Data returned by card	SW1, SW2

6.2.24. PAPDU_NFC_TYPE1_TAG_RSEG

This command issues a RSEG to read out a complete segment (or block) of the memory within dynamic memory model.

Please note that this command works only on specific Topaz tags in the dynamic memory model.

Command APDU:

Command	CLA	INS	P1	P2	P3	Data
TYPE1 Tag READ SEGMENT	FF	5A	00	SegAddr	00	-

Where P2 Segment Address is:

Bit numbers	Description
b7 – b4	Segment (0x0 – 0xF)
b2 – b0	0

Response APDU:

Data	Status Word
128 bytes of data	SW1, SW2

6.2.25. PAPDU_NFC_TYPE1_TAG_READ8

This command issues a READ8 to read out a block of eight bytes.

Please note that this command only works on Topaz tags in dynamic memory model.

Command APDU:

Command	CLA	INS	P1	P2	P3	Data
TYPE1 Tag READ BLOCK	FF	5C	00	Block Addr	00	-

Where P2 Block Address is:

Bit numbers	Description
b7 – b0	General block (0x00 -0xFF)

Response APDU:

Data	Status Word
8 bytes of data	SW1, SW2

6.2.26. PAPER NFC TYPE1 TAG WRITE E8

This command issues a WRITE8 to erase and then write a block of eight bytes.

Please note that this command only works on Topaz tags in dynamic memory model.

Command APDU:

Command	CLA	INS	P1	P2	P3	Data
TYPE1 Tag WRITE and ERASE BLOCK	FF	5E	00	Block Addr	08	Data

Where P2 Block Address is:

Bit numbers	Description
b7 – b0	General block (0x00 -0xFF)

Response APDU:

Data	Status Word
8 bytes of data that have been written	SW1, SW2

6.2.27. PAPER NFC TYPE1 TAG WRITE NE8

This command issues a WRITE8 to write a block of eight bytes. It does not erase the value of the targeted byte before writing the new data. Using this command, EEPROM bits can be set but not reset.

Please note that this command only works on Topaz tags in dynamic memory model.

Command APDU:

Command	CLA	INS	P1	P2	P3	Data
TYPE1 Tag WRITE and NO ERASE BLOCK	FF	60	00	Block Addr	08	Data

Where P2 Block Address is:

Bit numbers	Description
b7 – b0	General block (0x00 -0xFF)

Response APDU:

Data	Status Word
8 bytes of data	SW1, SW2

6.3. Escape commands for the CLOUD 47x0 F

With Amendment 1 of the PC/SC specification, Part 3, a method to define vendor specific commands has been introduced.

CLOUD 47x0 F provides the command [READER GENERIC ESCAPE](#) to send commands using this method. However, most of the escape commands listed here are not defined according to this method because of backward compatibility reasons.

All newly defined commands will adhere to this new standard. See the command [CONTACT_READ_INSERTION_COUNTER](#) as an example.

6.3.1. Sending Escape commands to CLOUD 47x0 F

A developer can use the following methods to send Escape commands to CLOUD 47x0 F

- SCardControl method defined in PC/SC API
- SCardTransmit method defined in PC/SC API in conjunction with the Escape command APDU [defined in this manual](#)
Please note, that SCardTransmit will only work when connected to a card.

In Windows, in order to be able to send Escape commands for the CLOUD 47x0 F, the feature has got to be enabled by setting a REG_DWORD value named 'EscapeCommandEnable' in the registry to a value of '1'.

For Windows XP and Windows Vista, the key to hold the value would be [HKEY_LOCAL_MACHINE\SYSTEM\CurrentControlSet\Enum\USB\VID_04E6&PID_5810\Device-Instance-xxxx \Device Parameters](#)

For Windows 7 and Windows 8, that would be [HKEY_LOCAL_MACHINE\SYSTEM\CurrentControlSet\Enum\USB\VID_04E6&PID_5810\Device-Instance-xxxx \Device Parameters\WUDFUsbccidDriver](#)

Device-Instance-xxxx has got to be equal to the serial number of the reader used, so this modification has got to be made for every physical reader intended to be used on the machine in question. The reader has got to be plugged in at least once for the mentioned key to exist and the driver has got to be restarted for this setting to take effect. (Unplug and re-plug the reader).

To be able to work with synchronous memory cards using our MCard API, the same setting will have to be established.

See appendix B for some sample code sending Escape commands to the reader.

6.3.2. Escape command codes

Escape commands can be used by an application to configure CLOUD 47x0 F to function in a mode that is not its default configured mode or to get specific information. To put the CLOUD 47x0 F back into its default mode, it either has to be unplugged and plugged again or the application can send the same Escape command again.

The following Escape commands are supported by CLOUD 47x0 F:

6.3.3. Common for Contact and Contactless Interfaces

ESCAPE COMMAND	ESCAPE CODE
READER_SETMODE	0x01
READER_GETMODE	0x02
READER_GETIFDTYPE	0x12
READER_LED_CONTROL	0x19
READER_GETINFO_EXTENDED	0x1E
READER_LED_CONTROL_BY_FW	0xB2
READER_RDWR_USR_AREA	0xF0
READER_GENERIC_ESCAPE	FF 70 04 E6 XX

6.3.3.1. READER_SETMODE

This Escape command sets the current mode of the reader. Applications may call this function, to set the desired mode. Typically, this call is used to switch between the ISO7816, EMV, Memory card and NFC test mode operations. Upon power on the reader will reset to the default ISO7816 mode.

Input:

The first byte of the input buffer contains the escape code value and the second one contains the value for the desired mode of operation. The output buffer field shall be NULL.

Byte0	Byte1
Escape code (0x01)	Mode

The following table defines the values for the Mode parameter:

Mode	Value	Remarks
ISO 7816	0x00	ISO 7816 mode – Applicable for both contact slot and contactless slot
EMV	0x01	EMV – Applicable only for contact slot and ignored by contactless interface
Synchronous	0x02	Memory card mode (Synchronous) – Applicable only for contact slot and ignored by contactless interface
NFC Test	0x04	NFC Test Mode – Applicable only for contactless interface

ISO mode uses APDU mode of data transfer and is used for normal operation. This is the default mode of the reader on Power up.

EMV mode also uses APDU mode of data transfer and is used for EMV test purposes. This mode has more stringent checks for Smartcard detection and Communication as per EMV4.2 spec.

Synchronous mode is used for communicating only with Memory cards.

NFC test mode is used to ignore deactivate-activate sequence during SCardConnect. (PC_TO_RDR_ICCPOWERON - 0x62, and PC_TO_RDR_ICCPOWEROFF – 0x63)

Output:

Output buffer
NULL

6.3.3.2. READER_GETMODE

This Escape command retrieves the current mode of the reader.

Input:

The input buffer contains the escape code value.

Byte0
Escape code(0x02)

Output:

The currently active reader mode will be returned as a byte value

Mode	Value	Remarks
ISO	0x00	ISO 7816 mode
EMV	0x01	EMV mode
Synchronous	0x02	Memory card mode (synchronous)
NFC Test	0x04	NFC Test Mode

6.3.3.3. READER_GET_IFDTYPE

This Escape command is used to get the current IFD type from the reader.

Input:

The first byte of the input buffer contains the escape code.

Byte0
Escape code(0x12)

Output:

The reader returns its PID LSB first.

PID value		Description
B0	B1	
0x20	0x57	Identive CLOUD 4700 F Dual Interface Reader
0x21	0x57	Identive CLOUD 4710 F Contactless + SAM Reader
0x10	0x57	Identive CLOUD 2700 F Smart Card Reader
0x50	0x57	Identive CLOUD 2910 F Smart Card Keyboard Reader

6.3.3.4. READER_LED_CONTROL

This Escape command is used to toggle the LED state. LED control by firmware should be disabled using the escape command [READER_LED_CONTROL_BY_FW](#) to see proper LED change when using this IOCTL.

Input:

The first byte of the input buffer contains the escape code, followed by LED number (if more than one LED is present, else set to 0) and then desired LED state. This will be required for production purpose.

Byte0	Byte 1	Byte2
Escape code(0x19)	LED number (0-RED,1-GREEN)	LED state (0-OFF, 1-ON)

Output:

Output buffer
NULL

6.3.3.5. READER_GET_INFO_EXTENDED

This Escape command is used to get the firmware version, reader capabilities, and Unicode serial number of the reader.

Input:

The first byte of the input buffer contains the escape code.

Byte0
Escape code(0x1E)

Output:

The firmware will return data as per structure SCARD_READER_GETINFO_PARAMS_EX mentioned below.

Field Size in Bytes	Field Name	Field Description	Value/Default
1	byMajorVersion	Major Version in BCD	Based on current firmware version
1	byMinorVersion	Minor Version in BCD	
1	bySupportedModes	Bit map indicating the supported modes of the reader. 0x01 => EMV mode 0x02 => Memory card mode 0x04 =>Nfc test mode	0x07 for Contact + Contactless readers 0x03 for Contact only readers Note: ISO mode is not indicated as it is always supported.
2	wSupportedProtocols	Protocols supported by the Reader Bit 0 – T0 Bit 1 – T1	0x0003 Received as LSB first
2	winputDevice	IO_DEV_NONE 0x00 IO_DEV_KEYPAD 0x01 IO_DEV_BIOMETRIC 0x02	0x0000 Received as LSB first
1	byPersonality	Reader Personality (Not Used)	0x00
1	byMaxSlots	Maximum number of slots	0x02 (contact and contactless)
1	bySerialNoLength	Serial number length (0x1C)	0x1C
28	abySerialNumber	Unicode serial number	Reader serial number Received as MSB first

6.3.3.6. READER_LED_CONTROL_BY_FW

This Escape command is used to enable/disable LED control by firmware.

Input:

The first byte of the input buffer contains the escape code. The second byte specifies if LED control by firmware should be disabled or enabled. The output buffer is NULL.

Byte0	Byte1 Value	Description
Escape code(0xB2)	0	Enable LED Control by firmware
	1	Disable LED Control by firmware
	FF	Get State: 0 -- LED control by firmware enabled 1 -- LED control by firmware disabled

Output:

No response is returned for set state. For Get State 1 byte response is received.

Output buffer
NULL or current state

6.3.3.7. READER_RD_WR_USER_AREA

This Escape command is used to access the user data area in the reader. The user area is located in the non-volatile memory of the reader and hence data will be retained even after power cycle.

Note:

- Frequent writes should be avoided (The non-volatile memory supports only 100K writing cycles).
- A maximum of 249 bytes can be read and written. The sector can be read and written only as a whole.
- If complete data (249 bytes) is not given during write operation then random data will be padded to the given data and then written. If you want to modify only part of the data, read the entire 249 bytes, modify the data you want to change and then write it back to the reader.

Input:

The first byte of the input buffer contains the escape code. The second byte specifies if user area is to be read or written as described below.

Byte0	Byte1		Byte2 to Byte251
	Value	Description	
Escape code(0xF0)	1	Read 249 bytes of user data	None
	2	Write 249 bytes of user data	Data to be written

Output:

Operation	Data (Byte0-BYTE248)
Read	249 bytes of user data
Write	No bytes returned

6.3.3.8. READER_GENERIC_ESCAPE

This Escape command is used to invoke newly defined escape functions and send proprietary commands to the reader. It is defined in line with vendor specific generic command defined in [PCSC3-AMD1].

Input:

The first five bytes of the input buffer shall follow APDU structure as per [PCSC3-AMD1]. 6TH byte shall be the command code used to identify the specific command.

Byte0	Byte1	Byte2	Byte3	Byte4	From Byte5 (up to Lc bytes)		
					Byte 5	Byte 6 onwards	ByteLc+5
0xFF	0x70	0x04	0xE6	Lc (always > 0)	Cmd Opcode	Command parameters or data	Le (optional)

Output:

Depending on the command, the output shall be Le bytes of data + SW1 + SW2 or SW1+SW2. The escape message shall at least return 2 bytes status word SW1, SW2. In case of success, SW1=0x90 and SW2=0x00 shall be returned. In error scenario, appropriate error status shall be returned (as defined in Error Code section 8.0).

6.3.3.9. READER_CONTROL_CONTACT_SLOT

This Escape command is supported through the [READER_GENERIC_ESCAPE](#) message.

This command can be used to disable the contact slot until it is re-enabled through the same command or until the reader is re-plugged. When a dual interface card is placed in the contact slot it will get detected in both “contact” and “contactless” mode. To enable applications to actively switch the detection from contact-only mode to contactless-only mode this Escape command can be used along with [CNTLESS_SWITCH_RF_ON_OFF](#).

Input

To Enable / Disable / “Get-Current-Status” of Contact Slot

Byte0	Byte1	Byte2	Byte3	Byte4	Byte5	Byte6	Byte7	Le
CLA	INS	P1	P2	Lc				
0xFF	0x70	0x04	0xE6	0x03	0x05 (opcode)	0x01	0x01 – to enable 0x00 – to disable	00
0xFF	0x70	0x04	0xE6	0x02	0x05 (opcode)	0x00 - to get current contact status		00

Byte2 and Byte3 constitute the world wide unique vendor ID as assigned by the USB organization. For Identive based readers Byte2 = 0x04 and Byte3 = 0xE6 since its USB Vendor ID is 0x04E6

Output:

If the command is successful, a single byte is returned. This byte indicates the status of contact slot which needs to be interpreted as below.

Byte 0	Description
0x01	Contact slot is enabled
0x00	Contact slot is disabled

6.3.4. Specific for Contactless Interface

ESCAPE COMMAND	ESCAPE CODE
CNTLESS_GETCARDINFO	0x11
CNTLESS_GET_ATS_ATQB	0x93
CNTLESS_CONTROL_PPS	0x99
CNTLESS_RF_SWITCH	0x96
CNTLESS_SWITCH_RF_ON_OFF	0x9C
CNTLESS_GET_BAUDRATE	0x9E
CNTLESS_CONTROL_RETRIES	0xA7
CNTLESS_CONTROL_POLLING	0xAC
CNTLESS_GET_CARD_DETAILS	0xDA
CNTLESS_SET_CONFIG_PARAMS	0xE1
CNTLESS_IS_COLLISION_DETECTED	0xE4
CNTLESS_FELICA_PASS_THRU	0xF3
CNTLESS_P2P_SWITCH_MODES	0xE9
CNTLESS_P2P_TARGET_RECEIVE	0xEA
CNTLESS_P2P_TARGET_SEND	0xEB
CNTLESS_P2P_INITIATOR_DESELECT	0xE6
CNTLESS_P2P_INITIATOR_TRANSCEIVE	0xE7
CNTLESS_NFC_SINGLESHOT	0xEC
CNTLESS_NFC_LOOPBACK	0xED
CNTLESS_GET_SET_NFC_PARAMS	READER_ESCAPE_GENERIC (0x04)
CNTLESS_GET_P2P_EXTERNAL_RF_STATE	READER_ESCAPE_GENERIC (0x06)

6.3.4.1. CNTLESS_GET_CARD_INFO

This Escape command is used to get information about the contactless card placed in the field of the reader.

Input:

The first byte of input buffer contains the escape code.

Byte0
Escape code(0x11)

Output:

Byte0	Byte1	Byte2
Contactless card present (0x01)	Card to Reader communication baud rate (0xNN - see table below for details)	Card Type Info (Upper nibble indicates memory card/T=CL/dual mode card; Lower nibble indicates Type A/ Type B card See Table below for values)

Card to Reader communication baud rate BYTE is defined as follows:

- b0 – 212kbps supported (direction reader to card)
- b1 – 424kbps supported (direction reader to card)
- b2 – 848kbps supported (direction reader to card)
- b3 – always 0
- b4 – 212kbps supported (direction card to reader)
- b5 – 424kbps supported (direction card to reader)
- b6 – 848kbps supported (direction card to reader)
- b7– 1 – indicates same baud rate in both directions
 0 – indicates different baud rates in both directions

Example:

If 0xNN = 0x77, the card supports all baud rates namely 106, 212, 424 and 848 kbps in both directions.

If 0xNN = 0xB3, the card supports 106, 212 and 424 kbps in both directions.

Card Type Info:

Upper Nibble Value	Description
0	Memory card
1	T=CL card
2	Dual mode card
Lower Nibble Value	
0	Type A card
1	Type B card

6.3.4.2. CNTLESS_GET_ATS_ATQB

This Escape command retrieves the ATS for Type A T= CL or the ATQB for Type B cards.

Input:

The first byte of input buffer contains the escape code.

Byte0
Escape code(0x93)

Output:

The output buffer contains the ATS bytes or the ATQB bytes depending on the type of PICC placed on the reader

6.3.4.3. CNTLESS_CONTROL_PPS

This Escape command disables the automatic PPS done by the firmware/device for contactless cards.

Input:

The first byte of input buffer contains the escape code.

The second byte either sets the mode or contains a code to retrieve the setting.

Input		Output
Byte0	Byte1 - PPS control byte	Byte0
Escape code(0x99)	0	Enable
	1	Disable
	FF	Get current status
		No Output
		No Output
		0 – PPS is enabled 1 – PPS is disabled

Output:

No response is returned for set state. For Get State 1 byte response is received.

Output buffer
NULL or current state

6.3.4.4. CNTLESS_RF_SWITCH

This Escape command can be used to switch the RF field ON or OFF.

Input:

The first byte of input buffer contains the escape code.

The second byte either sets the mode or contains a code to retrieve the setting.

Byte0	Byte1		Output
	Value	Description	Byte0
Escape code(0x96)	0x00	Switch RF Field OFF	No Output
	0x01	Switch RF Field ON	No Output
	0xFF	Get current field state	0 – RF field is ON 1 – RF field is OFF

Output:

No response is returned for set state. For Get State 1 byte response is received.

Output buffer
NULL or current state

6.3.4.5. CNTLESS_SWITCH_RF_ON_OFF

This Escape command is used to switch the RF field ON or OFF when a contact smart card is inserted into the reader. By default, the RF field is always in the ON state and when a contact smart card is inserted in the reader, the RF field is turned OFF.

Input:

The first byte of input buffer contains the escape code.

The second byte either sets the mode or contains a code to retrieve the setting.

Byte0	Byte1		Output
	Value	Description	Byte 0
Escape code(0x9C)	0x00	Switch RF Field OFF when contact card is present in the reader	No Output
	0x01	Leave RF Field ON when contact card is present in the reader	No Output
	0xFF	Get current field state	0x00 - RF is OFF when contact card is present in the reader 0x01 - RF is ON when contact card is present in the reader

After the RF is turned off, to turn the RF ON again, card connect has to be done in direct mode.

Output:

No response is returned for set state. For Get State 1 byte response is received.

Output buffer
NULL or current state

6.3.4.6. CNTLESS_GET_BAUDRATE

This Escape command is used to get the current baud rate of card-reader communication.

Input:

The first byte of input buffer contains the escape code.

Byte0
Escape code(0x9E)

Output:

The output contains a byte with the following possible values

Byte0	Description
0x00	106Kbps in both directions
0x01	106Kbps from PICC to PCD, 212Kbps from PCD to PICC
0x02	106Kbps from PICC to PCD, 424Kbps from PCD to PICC
0x03	106Kbps from PICC to PCD, 848Kbps from PCD to PICC
0x10	212Kbps from PICC to PCD, 106Kbps from PCD to PICC
0x11	212Kbps in both directions
0x12	212Kbps from PICC to PCD, 424Kbps from PCD to PICC
0x13	212Kbps from PICC to PCD, 848Kbps from PCD to PICC
0x20	424Kbps from PICC to PCD, 106Kbps from PCD to PICC
0x21	424Kbps from PICC to PCD, 212Kbps from PCD to PICC
0x22	424Kbps in both directions
0x23	424Kbps from PICC to PCD, 848Kbps from PCD to PICC
0x30	848Kbps from PICC to PCD, 106Kbps from PCD to PICC
0x31	848Kbps from PICC to PCD, 212Kbps from PCD to PICC
0x32	848Kbps from PICC to PCD, 424Kbps from PCD to PICC
0x33	848Kbps in both directions

6.3.4.7. CNTLESS_CONTROL_RETRIES

This Escape command is used to enable/disable CRC/PROTOCOL/TIMEOUT error retries which are enabled by default for contactless cards.

Input:

The first byte of input buffer contains the escape code.

The second byte either sets the mode or contains a code to retrieve the setting.

Input		Output	
Byte0	Byte1- Description	Byte 0	
Escape code(0xA7)	0x00	Enable RNAK retries	No Output
	0x01	Disable RNAK retries	No Output
	0xFF	Get current state of retries	0x00 - Retries are enabled 0x01 - Retries are disabled

Output:

No response is returned for set state. For Get State 1 byte response is received.

Output buffer
NULL or current state

6.3.4.8. CNTLESS_CONTROL_POLLING

This Escape command is used to enable/disable firmware polling for contactless cards.

Input:

The first byte of input buffer contains the escape code.

The second byte either sets the mode or contains a code to retrieve the setting.

Input		Output	
Byte0	Byte1 - Description	Byte 0	
Escape code(0xAC)	0x00	Enable polling	No output
	0x01	Disable polling	No output
	0xFF	Get current state of polling	0x00 – Polling enabled 0x01 – Polling disabled

Output:

No response is returned for set state. For Get State 1 byte response is received.

Output buffer
NULL or current state

6.3.4.9. CNTLESS_GET_CARD_DETAILS

This Escape command is used to get details about the PICC placed in the field of the reader.

Input:

The first byte of input buffer contains the escape code.

Byte0
Escape code(0xDA)

Output:

Byte #	Value	Description
B0	0x00	Type A card
	0x01	Type B card
	0x04	FeliCa 212
	0x08	FeliCa 424
B1	0x00	Memory card
	0x01	T-CL card
	0x02	Dual interface card
	0x43	FeliCa
	0x44	Topaz
	0x45	B-prime
	0x46	i-Class
B2	'xx'	'xx' is the PUPI / UID Length
	0x08	For FeliCa cards
THEN EITHER		
B3-B12		PUPI/UID bytes 0x00 byte padding used if length smaller than 10
B13	0x00	CID not supported
	0x01	CID supported
B14	0x00	NAD not supported
	0x01	NAD supported
B15		Bit Rate Capability
B16		FWI
B17		IFSC
B18		MBLI
B19		SAK
B20		SFGI
OR		
B3–B10		8 Bytes NFCID2
B11		Request service command response time parameter (see JIS-6319 specification)
B12		Request response command response time parameter
B13		Authentication command response time parameter
B14		Read command response time parameter
B15		Write command response time parameter

6.3.4.10. CNTLESS_SET_CONFIG_PARAMS

This Escape command is used to configure RXGAIN and RXTHRESHOLD of the RF receiver for different baud rates and card types. All configured parameters are volatile.

Input:

The first byte of input buffer contains the escape code. The following 16 bytes contain the below defined parameters.

Byte #	Value	Description
B0	0XE1	Escape code
B1		Type A RXGAIN for polling or 106Kbps
B2		Type A RXGAIN for 212 Kbps
B3		Type A RXGAIN for 424 Kbps
B4		Type A RXGAIN for 848 Kbps
B5		Type A RX THRESHOLD for polling or 106Kbps
B6		Type A RX THRESHOLD for 212 Kbps
B7		Type A RX THRESHOLD for 424 Kbps
B8		Type A RX THRESHOLD for 848 Kbps
B9		Type B RXGAIN for polling or 106Kbps
B10		Type B RXGAIN for 212 Kbps
B11		Type B RXGAIN for 424 Kbps
B12		Type B RXGAIN for 848 Kbps
B13		Type B RX THRESHOLD for polling or 106Kbps
B14		Type B RX THRESHOLD for 212 Kbps
B15		Type B RX THRESHOLD for 424 Kbps
B16		Type B RX THRESHOLD for 848 Kbps

Output:

Output buffer
NULL

6.3.4.11. CNTLESS_IS_COLLISION_DETECTED

This Escape command is used to identify if multiple Type A cards are detected in the field.

Input:

The first byte of input buffer contains the escape code.

Byte0
Escape code(0xE4)

Output:

Byte0	
Value	Description
0x00	Collision is not detected
0x01	Collision is detected

6.3.4.12. CNTLESS_FELICA_PASS_THRU

This Escape command is used as a pass through to send FeliCa commands to FeliCa cards.

Input:

The first byte of input buffer contains the escape code followed by FeliCa command to be sent to the card. At least 1 byte of command is required to be sent to the card. Otherwise an error will be reported.

Byte0	Byte1 onwards
Escape code (0xF3)	FeliCa command bytes

Output:

The response received from the FeliCa card is sent as output for this escape command.

6.3.4.13. CNTLESS_P2P_SWITCH_MODES

This Escape command is used to switch the device between the reader/writer and P2P modes of operation and to query the current mode. By default, the device is in the reader/writer mode.

Input:

The first byte of input buffer contains the escape code.

The second byte either sets the mode or contains a code to retrieve the setting.

Additional data bytes will be needed for Initiator/Target mode.

Offset	Description	Detailed description
0	0xE9	Switch mode
1	0 – P2P Initiator mode 1 – P2P Target mode 2 – Reader / writer mode 0xFF – Get current mode	For the switch to Initiator / Target mode, the bytes from offset 0x02 give additional information as described below

Offset	Initiator Mode Bytes	Detailed description
2		RFU
3		RFU
4		Timeout Low Byte
5		Timeout High Byte
6	N	Number of General Bytes
7 to N+7	General bytes to be sent in ATR-REQUEST	

Offset	Target Mode Bytes (Sample Values)	Detailed description
2	0x00	RFU
3	0x00	RFU
4	0x04	SENS_RES
5	0x03	SENS_RES
6	0x01	NFCID1
7	0xFE	NFCID1
8	0x0F	NFCID1
9	0x40	SEL_RES
10	0x01	NFCID2
11	0xFE	NFCID2
12	0x0F	NFCID2
13	0xBB	NFCID2
14	0xBA	NFCID2
15	0xA6	NFCID2
16	0xC9	NFCID2
17	0x89	NFCID2
18	C0	FeliCa Padding Bytes
19	C1	FeliCa Padding Bytes
20	C2	FeliCa Padding Bytes
21	C3	FeliCa Padding Bytes
22	C4	FeliCa Padding Bytes
23	C5	FeliCa Padding Bytes
24	C6	FeliCa Padding Bytes
25	C7	FeliCa Padding Bytes
26	FF	FeliCa System Code
27	FF	FeliCa System Code
28	0x00	NFCID3 (XOR of 0x08 and 3 bytes of NFCID1)
29	0x88	Timeout Low Byte
30	0x13	Timeout High Byte
31	N	Number of G bytes in ATR_RES
32 to N+32	General byte to be sent in ATR_RES	

Output Buffer:

- Initiator Mode : On successful detection of target, the entire ATR_RES buffer from the target device would be given to the host computer
- Target Mode : On successful detection by the initiator the entire ATR_REQ buffer from the initiator device would be given to the host computer
- Reader Mode : The output buffer would be empty
- Get Current Mode : A single byte response indicating the currently selected mode as described below
 - 0x00 => P2P Initiator mode
 - 0x01 => P2P Target mode
 - 0x02 => Reader / Writer mode

6.3.4.14. CNTLESS_P2P_TARGET_RECEIVE

This Escape command is used to receive data from the initiator device. Prior to using this command, the device should have been successfully switched to target mode using [CNTLESS_P2P_SWITCH_MODES \(E9\)](#).

Input Buffer:

Offset	Description	Detailed description
0	0xEA	Target Receive
1		RFU
2		RFU
3		RFU
4	0 - No Chaining 1 - Chaining	Chaining byte
5	--	Timeout Low Byte
6	--	Timeout High Byte

Output Buffer:

On successful reception, the entire data from the initiator device would be returned from offset 0x04

Offset	Description	Detailed description
0		RFU
1		RFU
2		RFU
3	0 – No Chaining 1 – Chaining	Chaining
Offset 4 to offset 4+N	N data bytes	Bytes Received.

6.3.4.15. CNTLESS_P2P_TARGET_SEND

This Escape command is used to send data to an initiator device. Prior to using this command, the device should have been successfully switched to target mode using [CNTLESS_P2P_SWITCH_MODES \(E9\)](#).

Input:

Offset	Description	Detailed description
0	0xEB	Target Send
1	0x00	RFU
2	0x00	RFU
3	0x00	RFU
4	0 - No Chaining 1 - Chaining	Chaining byte
5		Timeout Low Byte
6		Timeout High Byte
Offset 7 to offset 7+N	N data bytes	Bytes to be sent to Initiator device

Output:

Once the data bytes are sent successfully, the firmware would indicate if it is ready to send more bytes through the chaining byte

Offset	Description	Detailed description
0		RFU
1		RFU
2		RFU
3	0 – No Chaining 1 – Chaining	Chaining

6.3.4.16. CNTLESS_P2P_INITIATOR_DESELECT

This escape command is used by the application to deselect the target device towards the end of P2P communication.

Input

Byte0
Escape code(0xE6)

Output

The deselect response as received from the target will be sent in the response buffer from offset 0x00

6.3.4.17. CNTLESS_P2P_INITIATOR_TRANCEIVE

This Escape command is used to send data to a target device. Prior to using this command, the device should have been successfully switched to initiator mode using [CNTLESS_P2P_SWITCH_MODES \(E9\)](#).

Input:

Offset	Description	Detailed description
0	0xE7	Initiator transceive
1	0x00	RFU
2	0x00	RFU
3	0x00	RFU
4	0 – No Chaining 1 – Chaining	Chaining
5	--	Timeout Low Byte
6	--	Timeout High Byte
Offset 7 to 7+N	N bytes of data	Bytes to be sent to target device

Output:

On successful reception of data from the target, the entire data would be available from offset 0x04. Presence of additional data is indicated by the chaining byte.

Offset	Description	Detailed description
0		RFU
1		RFU
2		RFU
3	0 – No Chaining 1 – Chaining	Chaining
Offset 4 to offset 4+N	N data bytes	Bytes Received.

6.3.4.18. CNTLESS_NFC_SINGLESLOT

This Escape command is used to switch the device to Single-shot mode.

Input:

Offset	Description	Detailed description
0	0xEC	NFC Single-shot
1	0x01	NFC_DEP supported. If a value other than 0x01 is given, NFC_DEP is not supported in the preceding I-Blocks.

Output:

Output buffer
NULL

6.3.4.19. CNTLESS_NFC_LOOPBACK

This Escape command is used to switch the device to Loop-back mode.

Input:

Offset	Description	Detailed description
0	0xED	NFC Loop-back
1	0x01	NFC_DEP supported. If a value other than 0x01 is given, NFC_DEP is not supported in the preceding I-Blocks.

Output:

Output buffer
NULL

6.3.4.20. CNTLESS_GET_SET_NFC_PARAMS

This Escape command is supported through the [READER_GENERIC_ESCAPE](#) command.

During NFC operation, number parameters like DID, LRi, PSL_REQ_BRS and PSL_REQ_FSL can be controlled from application.

Input:

To set the parameters the command syntax is:

Byte0	Byte1	Byte2	Byte3	Byte4	Byte5	Byte6	Byte7	Byte 8	Le	
CLA	INS	P1	P2	Lc						
0xFF	0x70	0x04	0xE6	0x04	0x04 (opcode)	0x01 SET	-	NFC Parameter	Value	00

To get the parameters the command syntax is:

Byte0	Byte1	Byte2	Byte3	Byte4	Byte5	Byte6	Byte7	Le
CLA	INS	P1	P2	Lc				
0xFF	0x70	0x04	0xE6	0x03	0x04 (opcode)	0x00 – GET	NFC Parameter	00

The value of byte 7 is interpreted from this table

Byte 7 Value	Description
0x00 – DID	Device Identification Number
0x01 – LRi	Length Reduction field
0x02 – PSL_REQ_BRS	BRS used in PSL_REQ
0x03 – PS_REQ_FSL	FSL used in PSL_REQ

6.3.4.21. CNTLESS_GET_P2P_EXTERNAL_RF_STATE

This Escape command is supported through the [READER_GENERIC_ESCAPE](#) message.

This command is used to check if external RF is reset after the reader got detected in target mode.

Input:

Byte0	Byte1	Byte2	Byte3	Byte4	Byte5	Le
CLA	INS	P1	P2	Lc		
0xFF	0x70	0x04	0xE6	0x01	0x06 (opcode)	00

Output:

If the command is successful, a single byte is returned. This byte indicates the value of parameter.

Bit 0 => Set to logic 1, when a present external RF field is switched off

Bit 1 => Set to logic 1, when an external RF field is detected.

Bit 2 to Bit 7 => RFU bits always read as 0

6.3.5. Specific for Contact Interface

ESCAPE COMMAND	Escape code
CONTACT_GET_SET_PWR_UP_SEQUENCE	0x04
CONTACT_EMV_LOOPBACK	0x05
CONTACT_EMV_SINGLEMODE	0x06
CONTACT_EMV_TIMERMODE	0x07
CONTACT_APDU_TRANSFER	0x08
CONTACT_DISABLE_PPS	0x0F
CONTACT_EXCHANGE_RAW	0x10
CONTACT_GET_SET_CLK_FREQUENCY	0x1F
CONTACT_CONTROL_ATR_VALIDATION	0x88
CONTACT_GET_SET_MCARD_TIMEOUT	0x85
CONTACT_GET_SET_ETU	0x80
CONTACT_GET_SET_WAITTIME	0x81
CONTACT_GET_SET_GUARDTIME	0x82
CONTACT_READ_INSERTION_COUNTER	READER_ESCAPE_GENERIC (0x00)

6.3.5.1. CONTACT_GET_SET_PWR_UP_SEQUENCE

This Escape command is used to get or set the following parameters:

- Smart card Power-on sequence
- Delay between successive Activation retries
- Enable/Disable any Voltage Class

As soon as card insertion is detected and Power ON message is received from the host, the firmware will start Activation with the configured voltage sequence. If the Activation fails, it will wait for the configured Activation delay and then retry with the next enabled Voltage class. If power up succeeds at an operating voltage, the firmware will continue card communication at that voltage. If power up fails in all the enabled operating voltages, then the firmware will report an error.

Input:

The first byte of the input buffer will contain the escape code. The next byte shall contain the function to be performed. Third byte shall contain the parameter for the function.

Byte0	Byte1 Value	Description	Byte2
Escape code(0x04)	0x00	Starts with Class C voltage. (1.8V – 3V – 5V order)	-
	0x01	Starts with Class A voltage. (5V – 3V – 1.8V order)	-
	0x08	Time delay between resets	Delay value in milliseconds
	0x09	Enable/Disable a Voltage Class	Bit Map of all Voltage Classes [Bit0 – Class A; Bit1 – Class B; Bit2 – Class C] Set bit to enable the Voltage class Clear bit to disable the Voltage class
	0xFE	Retrieves all the Activation Configuration	-
	0xFF	Retrieves the current Power up sequence	-

Output:

For retrieving all settings (0xFE), the output will be:

Byte0		Byte 1	Byte2
Value	Description		
0x00	Starts with Class C voltage. (1.8V – 3V – 5V order)	Time delay between resets in milliseconds	Bit Map of all Voltage Classes [Bit0 – Class A; Bit1 – Class B; Bit2 – Class C]
0x01	Starts with Class A voltage. (5V – 3V – 1.8V order)		

For retrieving current Power up sequence (0xFF), the output will be:

Byte0	
Value	Description
0x00	Starts with Class C voltage. (1.8V – 3V – 5V order)
0x01	Starts with Class A voltage. (5V – 3V – 1.8V order)

6.3.5.2. CONTACT_EMV_LOOPBACK

This Escape command lets the host force the firmware to perform an EMV Loop-back application.

Input:

The input buffer contains the escape code value.

Byte0
Escape code(0x05)

Output:

Output buffer
NULL

6.3.5.3. CONTACT_EMV_SINGLEMODE

This Escape command lets the host perform a one-shot EMV Loop-back application as specified in the EMV Level 1 Testing Requirements document.

Input:

Byte0
Escape code(0x06)

Output:

Output buffer
NULL

6.3.5.4. CONTACT_EMV_TIMERMODE

This Escape command lets the host perform a timer mode EMV Loop-back application as specified in the EMV Level 1 Testing Requirements document

Input:

The input buffer contains the escape code value.

Byte0
Escape code(0x07)

Output:

Output buffer
NULL

6.3.5.5. CONTACT_APDU_TRANSFER

This Escape command exchanges a short APDU with the smart card. The user has to ensure that a card is inserted and powered before issuing this Escape command. This Escape command mostly is used by the MCard API to access synchronous memory cards.

Input:

The input buffer contains the Escape code value followed by the short APDU to be sent to the card.

Byte0	Byte1 onwards
Escape code(0x08)	Short APDU to be sent to card

Output:

Output buffer
Response APDU

6.3.5.6. CONTACT_DISABLE_PPS

This Escape command disables PPS done by the firmware/device for smart cards. This setting will take effect from the next card connect and remains effective till it is changed again or the next Reader power on. Default mode is PPS enabled.

Input:

The first byte of the input buffer contains the Escape code and the following byte, if 1 disables PPS and if 0 enables PPS.

Byte0	Byte1
Escape code(0x0F)	PPS control byte (1-DISABLES PPS, 0-ENABLES PPS)

Output:

Output buffer
NULL

6.3.5.7. CONTACT_EXCHANGE_RAW

This Escape command can be used to perform raw exchange of data with the card. The user must ensure that a card is inserted and powered on before issuing this Escape command. The Card is deactivated upon any reception error.

Input:

The input buffer for this command contains the Escape code, low byte of the length of data to be sent, high byte of length of data to be sent, low byte of the length of expected data, high byte of length of expected data and the command.

Byte0	Byte1	Byte2	Byte3	Byte4	Byte 5 onwards
Escape code(0x10)	LSB of send length	MSB of send length	LSB of expected length	MSB of expected length	Raw data to the card

Output:

Output buffer
Response APDU

6.3.5.8. CONTACT_GET_SET_CLK_FREQUENCY

This Escape command is used to instruct the reader to change the clock for the smart card or to get the current Clock divisor used. Once set, the change in frequency will take effect immediately. Default divisor value is 10, that is 4.8MHz.

Input:

The first byte of the input buffer contains the Escape code; the next byte contains the clock divisor value to set the clock frequency or 0xFF to get the clock frequency.

Byte0	Byte1	Description
Escape code(0x1F)	Clock divisor	The value to be Set in the smartcard CLK divisor register
	0xFF	Get current Clock divisor value

Output:

Set clock frequency: None

Get clock frequency: One byte value indicating the current Clock divisor.

Output buffer
NULL or current divisor

Clock Divisor values:

DIVISOR VALUE	SCCLK Frequency
12	4 MHz
10	4.8 MHz
8	6 MHz
7	6.8 MHz
6	8 MHz
5	9.6 MHz
4	12 MHz
3	16 MHz

6.3.5.9. CONTACT_CONTROL_ATR_VALIDATION

This Escape command is used to enable or disable the ATR validation by the firmware in ISO/IEC 7816 mode.

In case the card would emit an ATR that is not ISO/IEC 7816 compliant, the card reader may fail to power up the card. In these cases, disabling ATR validation will let you work with the card regardless of ISO conformity of the ATR.

By default, ATR validation is enabled.

Input:

The first byte of the input buffer will contain the Escape code; the next byte will contain the control byte.

Byte0	Byte1	
	Value	Description
Escape code(0x88)	0x00	Enable ATR validation
	0x01	Disable ATR validation

Output:

Output buffer
NULL

6.3.5.10. CONTACT_GET_SET_MCARD_TIMEOUT

This Escape command is used to get or set the delay which is applied after a Write operation to memory cards. The delay is specified in milliseconds.

Input:

The first byte of the input buffer will contain the Escape code; the next byte will contain the memory card write delay in seconds.

Byte0	Byte1	Description
	Value	
Escape code(0x85)	0x01	Delay in milliseconds for memory card Write
	Any value other than 1	Read the current applied delay for memory card Write

Output:

Write delay: No response byte

Read delay value: A byte value specifying the current delay applied during memory card Write in milliseconds

Byte0
Null or Delay in ms

6.3.5.11. CONTACT_GET_SET_ETU

This Escape command is used by the HOST to get/set the current ETU for smart cards. Once set, the new ETU value will take effect immediately.

Input:

The input buffer contains the Escape code followed by an 8 bit GET/SET identifier. For SET ETU, a DWORD specifying the value to be set is following.

Byte0	Byte1	Byte2	Byte3	Byte4	Byte5	
	Value	Description	Wait time			
Escape code(0x80)	0x01	SET ETU	BIT31-BIT24	BIT23-BIT16	BIT15-BIT8	BIT7-BIT0
	0x00	GET ETU	-	-	-	-

Output:

For both Set and Get ETU, the output will be the following.

Byte0	Byte1	Byte2	Byte3
ETU value			
BIT31-BIT24	BIT23-BIT16	BIT15-BIT8	BIT7-BIT0

6.3.5.12. CONTACT_GET_SET_WAITTIME

This Escape command is used to get/set the Character/Block Waiting Time for smartcards. The wait time is specified in terms of ETU. Once set, the new Wait time will take effect from the next card communication.

Input:

The input buffer contains the Escape code followed by an 8 bit GET/SET identifier, an 8 bit Wait time identifier and a 32 bit Wait time value. BWT must be specified in units of 1.25ms and CWT in units of ETU.

Byte0	Byte1		Byte2		Byte3	Byte4	Byte5	Byte6
	Value	Description	Value	Description	Wait time in ETU			
Escape code(0x81)	0x01	SET Wait time	0x00	CWT	BIT31-BIT24	BIT23-BIT16	BIT15-BIT8	BIT7-BIT0
			0x01	BWT				
	0x00	GET Wait time	0x00	CWT	-	-	-	-
			0x01	BWT	-	-	-	-

Output:

For both Get/Set Wait time, the output will be the following.

Byte0	Byte1	Byte2	Byte3
Wait time in ETU			
BIT31-BIT24	BIT23-BIT16	BIT15-BIT8	BIT7-BIT0

6.3.5.13. CONTACT_GET_SET_GUARDTIME

This Escape command is used to get/set the Character/Block Guard Time of the reader. The guard time is specified in terms of ETU. Once set, the new Guard time will take effect immediately.

Input:

The input buffer contains the Escape code followed by an 8 bit GET/SET identifier, an 8 bit guard time identifier and a 32 bit guard time value in ETU.

Byte0	Byte1	Byte2	Byte3	Byte4	Byte5	Byte6		
	Value	Description	Value	Description	Guard time in ETU			
Escape code(0x82)	0x01	SET Guard time	0x00	CGT	BIT31-BIT24	BIT23-BIT16	BIT15-BIT8	BIT7-BIT0
			0x01	BGT				
	0x00	GET Guard time	0x00	CGT	-	-	-	-
			0x01	BGT	-	-	-	-

Output:

For Get/Set guard time, the output will be the Character/Block Guard Time value.

Byte0	Byte1	Byte2	Byte3
Character Guard time in ETU			
BIT31-BIT24	BIT23-BIT16	BIT15-BIT8	BIT7-BIT0

6.3.5.14. CONTACT_READ_INSERTION_COUNTER

This Escape command is supported through the [READER_GENERIC_ESCAPE](#) command and retrieves the number of times a contact smart card has been inserted into the reader.

Input:

The first five bytes of the input buffer follow APDU structure as per [PCSC3-AMD1]. The 6th byte is the Escape code 0x00 to identify the command.

Byte0	Byte1	Byte2	Byte3	Byte4	Byte5	Le
0xFF	0x70	0x04	0xE6	0x01	0x00 (Escape code)	4 (Insertion counter is a 4 byte value)

Output:

Byte0	Byte1	Byte2	Byte3	Byte4	Byte5
Insertion counter value				SW1	SW2
BIT31-BIT24	BIT23-BIT16	BIT15-BIT8	BIT7-BIT0	0x90	0x00

In case of any error, only SW1 and SW2 set with error status will be returned.

7. Annexes

7.1. Annex A – Status words table

SW1	SW2	Description
0x90	0x00	NO ERROR
0x63	0x00	NO INFORMATION GIVEN
0x65	0x81	MEMORY FAILURE
0x67	0x00	LENGTH INCORRECT
0x68	0x00	CLASS BYTE INCORRECT
0x6A	0x81	FUNCTION NOT SUPPORTED
0x6B	0x00	WRONG PARAMETER P1-P2
0x6D	0x00	INVALID INSTRUCTION BYTE
0x6E	0x00	CLASS NOT SUPPORTED
0x6F	0x00	UNKNOWN COMMAND

7.2. Annex B – Sample code using escape commands

File Name: CLOUD 47x0 F Escape.h

```
#ifndef _CLOUD_47x0F_ESCAPE_H_
#define _CLOUD_47x0F_ESCAPE_H_

#ifdef __cplusplus
extern "C" {
#endif

# pragma pack (1)
typedef struct
{
    BYTE byMajorVersion;
    BYTE byMinorVersion;
    BYTE bySupportedModes;
    WORD wSupportedProtocols;
    WORD winputDevice;
    BYTE byPersonality;
    BYTE byMaxSlots;
    BYTE bySerialNoLength;
    BYTE abySerialNumber [28];
} ReaderInfoExtended;
# pragma pack ()

#define IOCTL_CCID_ESCAPE                SCARD_CTL_CODE (0xDAC)

#define READER_SET_MODE                   0x01
#define READER_GET_MODE                   0x02
#define READER_GETTFDTYPE                 0x12
#define READER_LED_CONTROL                0x19
#define READER_LED_CONTROL_BY_FW         0xB2
#define READER_GETINFO_EXTENDED           0x1E
#define READER_RDWR_USR_AREA              0xF0

#define CONTACT_GET_SET_POWERUPSEQUENCE  0x04
#define CONTACT_EMV_LOOPBACK              0x05
#define CONTACT_EMV_SINGLEMODE            0x06
#define CONTACT_EMV_TIMERMODE             0x07
#define CONTACT_APDU_TRANSFER             0x08
#define CONTACT_CONTROL_PPS               0x0F
#define CONTACT_EXCHANGE_RAW              0x10
#define CONTACT_GET_SET_CLK_FREQUENCY     0x1F
#define CONTACT_GET_SET_ETU               0x80
#define CONTACT_GET_SET_WAITTIME          0x81
#define CONTACT_GET_SET_GUARDTIME         0x82
#define CONTACT_GET_SET_MCARD_TIMEOUT     0x85
#define CONTACT_CONTROL_ATR_VALIDATION    0x88

#define CNTLESS_GETCARDINFO               0x11
#define CNTLESS_GET_ATS_ATQB              0x93
#define CNTLESS_CONTROL_PPS               0x99
#define CNTLESS_RF_SWITCH                 0x96
#define CNTLESS_SWITCH_RF_ON_OFF          0x9C
#define CNTLESS_GET_BAUDRATE              0x9E
#define CNTLESS_CONTROL_RETRIES           0xA7
#define CNTLESS_CONTROL_POLLING           0xAC
#define CNTLESS_GET_CARD_DETAILS           0xDA
#define CNTLESS_SET_CONFIG_PARAMS          0xE1
#define CNTLESS_IS_COLLISION_DETECTED     0xE4
#define CNTLESS_FELICA_PASS_THRU          0xF3
#define CNTLESS_P2P_SWITCH_MODES          0xE9
#define CNTLESS_P2P_TARGET_RECEIVE        0xEA
#define CNTLESS_P2P_TARGET_SEND           0xEB
#define CNTLESS_P2P_INITIATOR_TRANSCEIVE  0xE7
#define CNTLESS_NFC_SINGLESHOT             0xEC
#define CNTLESS_NFC_LOOPBACK              0xED

#ifdef __cplusplus
}
#endif

#endif
```

File Name: CLOUD 47x0 F Escape.c

```

#include <windows.h>
#include <winbase.h>
#include <stdio.h>
#include <conio.h>
#include "winscard.h"
#include "winerror.h"
#include "CLOUD 47x0F Escape.h"

VOID main(VOID)
{
    SCARDCONTEXT          ContextHandle;
    SCARDHANDLE           CardHandle;
    ReaderInfoExtended    strReaderInfo;
    BYTE                  InByte, i;
    DWORD                 BytesRead, ActiveProtocol;
    ULONG                 ret;
    char                  *s;
    char                  *ReaderName[] = {"Identive CLOUD 4700 F Contact Reader 0",
                                           "Identive CLOUD 4700 F Contactless Reader 0",
                                           NULL};

    /*****
    *****/

    ContextHandle = -1;

    ret = SCardEstablishContext(SCARD_SCOPE_USER, NULL, NULL, &ContextHandle);

    if (ret == SCARD_S_SUCCESS)
    {
        s = ReaderName[0];
        printf("Connecting to reader %s\n", s);
        ret = SCardConnect( ContextHandle,
                           s,
                           SCARD_SHARE_DIRECT,
                           SCARD_PROTOCOL_UNDEFINED,
                           &CardHandle,
                           &ActiveProtocol);

        if (ret == SCARD_S_SUCCESS)
        {
            InByte = 0x1E;
            ret = SCardControl( CardHandle,
                               IOCTL_CCID_ESCAPE,
                               &InByte,
                               1,
                               &strReaderInfo,
                               sizeof(strReaderInfo),
                               &BytesRead);
            if (SCARD_S_SUCCESS == ret) {
                printf("major version:\t\t%d\n", (strReaderInfo.byMajorVersion& 0xF0)>> 4,
                    (strReaderInfo.byMajorVersion& 0x0F));
                printf("minor version:\t\t%d\n", (strReaderInfo.byMinorVersion& 0xF0)>> 4,
                    (strReaderInfo.byMinorVersion& 0x0F));
                printf("modes:\t\t%d\n", strReaderInfo.bySupportedModes);
                printf("protocols:\t\t%04x\n", strReaderInfo.wSupportedProtocols);
                printf("input device:\t\t%04x\n", strReaderInfo.winputDevice);
                printf("personality:\t\t%d\n", strReaderInfo.byPersonality);
                printf("maxslots:\t\t%d\n", strReaderInfo.byMaxSlots);
                printf("serial no length:\t%d\n", strReaderInfo.bySerialNoLength);
                printf("serial no:\t\t");
                for (i = 0; i < strReaderInfo.bySerialNoLength; i++)
                    if (strReaderInfo.abySerialNumber[i] != 0) printf("%c",
strReaderInfo.abySerialNumber[i]);
            } else {
                printf("SCardControl failed: %08X\n", ret);
            }
        }
        else {
            printf("SCardConnect failed: %08X\n", ret);
        }
    }
}

```

```
        ret = SCardReleaseContext(ContextHandle);
    }
    else
    {
        printf("\n SCardEstablishContext failed with %.8lX",ret);
    }

    printf("\npress any key to close the test tool\n");
    getch();
}
```

7.3. Annex C – Mechanical drawings

7.3.1. Outline and cable positions

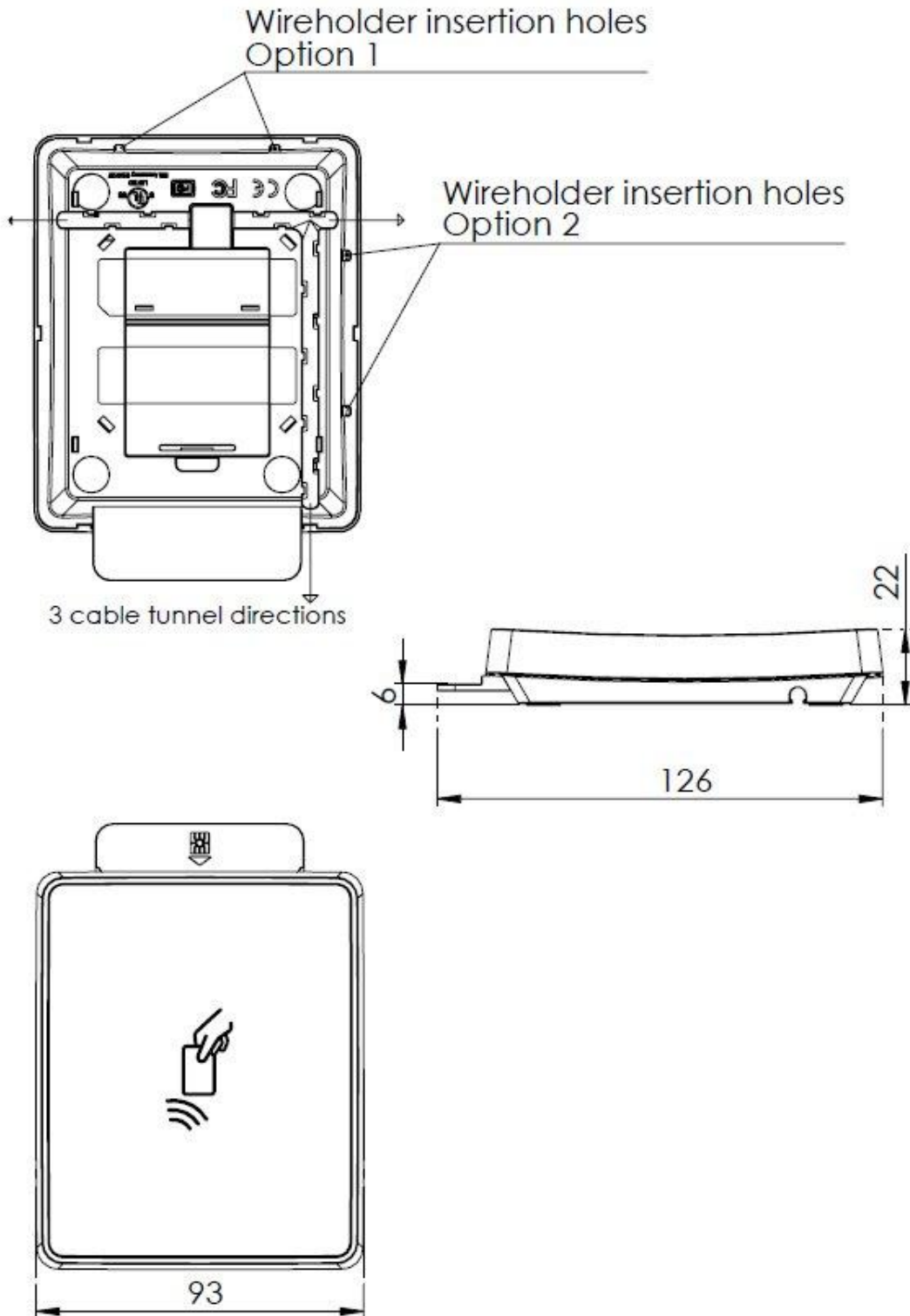

7.3.2. Stand

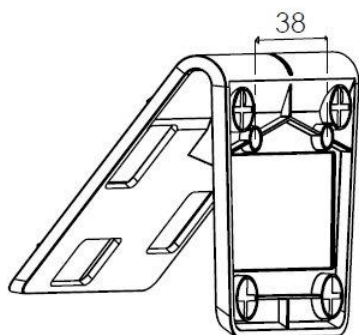
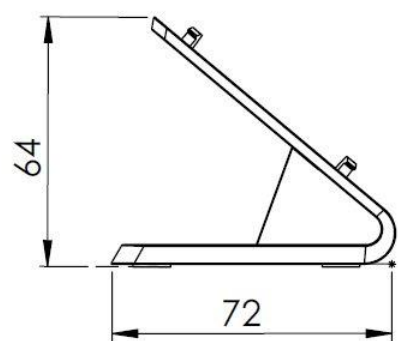
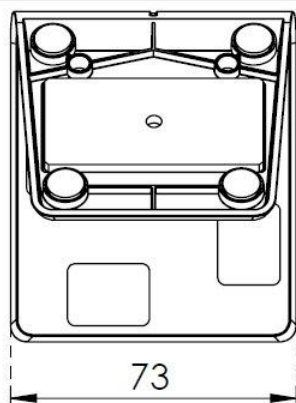

Wall mounting the reader

Screw max diameter: 5mm

7.3.3. Reader mounted to Stand

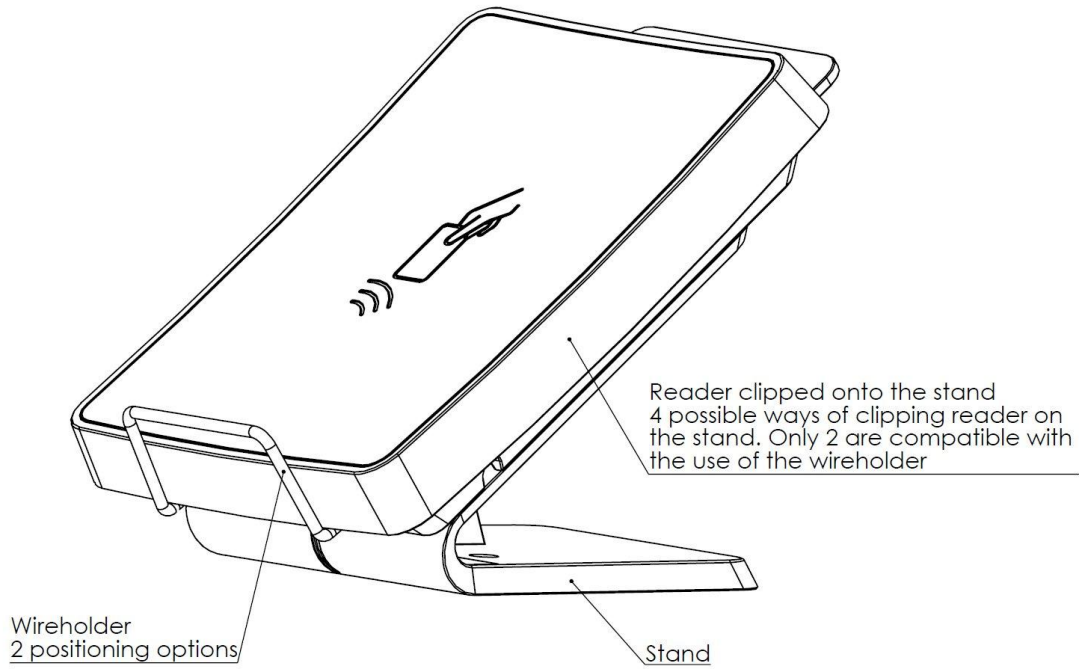

7.3.4. CLOUD 4710 F - SAM slot

