



Etiketten Thermotransferfolien Hard- und Software

**IDENTTECHNIK**

*It's always a good ID*

## ***TC200/ TC210/ TC300/ TC310 Series***

**THERMAL TRANSFER / DIRECT THERMAL  
BAR CODE PRINTER**

**SERVICE  
MANUAL**

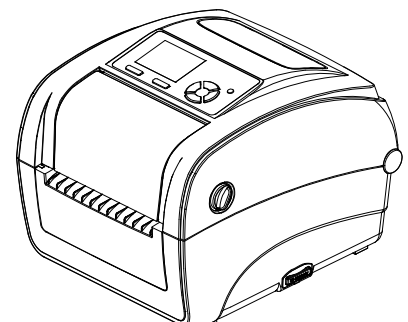
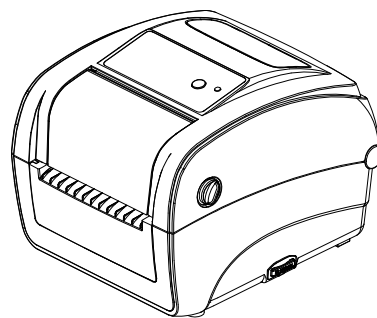

**TABLE OF CONTENT**

|   |           |
|---|-----------|
| <b>1. OVERVIEW .....</b>                                | <b>1</b>  |
| <b>1.1 Front View.....</b>                              | <b>1</b>  |
| <b>1.2 Interior View.....</b>                           | <b>3</b>  |
| <b>1.3 Rear View .....</b>                              | <b>4</b>  |
| <b>2. ELECTRONICS.....</b>                              | <b>5</b>  |
| <b>2.1 Summary of Board Connectors.....</b>             | <b>5</b>  |
| <b>2.2 Pin Configuration .....</b>                      | <b>12</b> |
| <b>3. MECHANISM.....</b>                                | <b>14</b> |
| <b>3.1 Replacing LED (Or LCD) Module.....</b>           | <b>14</b> |
| <b>3.2 Replacing the Main Board.....</b>                | <b>16</b> |
| <b>3.3 Replacing the Head Open Sensor .....</b>         | <b>17</b> |
| <b>3.4 Replacing the Platen Roller Assembly .....</b>   | <b>18</b> |
| <b>3.5 Replacing the Print Head Assembly .....</b>      | <b>19</b> |
| <b>3.6 Replacing the Stepping Motor .....</b>           | <b>21</b> |
| <b>3.7 Replacing the Black-mark Sensor Module .....</b> | <b>22</b> |
| <b>3.8 Replacing the Gap Sensor (Transmitter).....</b>  | <b>23</b> |
| <b>3.9 Replacing the Media Holder.....</b>              | <b>24</b> |
| <b>3.10 Peel-off Module Installation (Option).....</b>  | <b>27</b> |
| <b>3.11 Cutter Module Installation (Option).....</b>    | <b>30</b> |
| <b>4. TROUBLESHOOTING .....</b>                         | <b>32</b> |
| <b>5. MAINTENANCE .....</b>                             | <b>36</b> |
| <b>UPDATE HISTORY .....</b>                             | <b>38</b> |

## 1. OVERVIEW

### 1.1 Front View



**\* Recommended SD card specification**

**For TC210 series**

| SD card spec      | SD card capacity | Approved SD card manufacturer |
|-------------------|------------------|-------------------------------|
| V2.0 SDHC CLASS 4 | 2 GB             | Transcend                     |
| V2.0 SDHC CLASS 4 | 8 GB             | SanDisk                       |

# TC200/ TC210/ TC300/ TC310 Series Bar Code Printer Service Manual



|   |               |                     |
|---|---------------|---------------------|
| V3.0 CLASS 10 UHS   | 16 GB         | SanDisk             |
| V3.0 CLASS 10 UHS   | 32 MB         | Transcend           |
| V2.0 SDHC CLASS 4   | microSD 4GB   | Transcend           |
| V2.0 SDHC CLASS 4   | microSD 16 GB | SanDisk             |
| V3.0 CLASS 10 UHS   | microSD 16GB  | Transcend, Kingston |
| V3.0 CLASS 10 UHS   | microSD 32 GB | SanDisk             |
| <ul style="list-style-type: none"> <li>- The DOS FAT file system is supported for the SD card.</li> <li>- Folders/files stored in the SD card should be in the 8.3 filename format</li> <li>- The miniSD/microSD card to SD card slot adapter is required.</li> </ul> |               |                     |

## For TC200 series

| SD card spec  | SD card capacity | Approved SD card manufacturer |
|---|------------------|-------------------------------|
| V1.0, V1.1  | 128 MB           | SanDisk, Transcend            |
| V1.0, V1.1  | 256 MB           | SanDisk, Transcend, Panasonic |
| V1.0, V1.1  | 512 MB           | SanDisk, Transcend, Panasonic |
| V1.0, V1.1  | 1 GB             | SanDisk, Transcend, Panasonic |
| V2.0 SDHC CLASS 4   | 4 GB             |                               |
| V2.0 SDHC CLASS 6   | 4 GB             | SanDisk, Transcend, Panasonic |
| V1.0, V1.1  | microSD 128 MB   | Transcend, Panasonic          |
| V1.0, V1.1  | microSD 256 MB   | Transcend, Panasonic          |
| V1.0, V1.1  | microSD 512 MB   | Panasonic                     |
| V1.0, V1.1  | microSD 1 GB     | Transcend, Panasonic          |
| V2.0 SDHC CLASS 4   | microSD 4 GB     | Panasonic                     |
| V2.0 SDHC CLASS 6   | microSD 4 GB     | Transcend                     |
| V1.0, V1.1  | miniSD 128 MB    | Transcend, Panasonic          |
| V1.0, V1.1  | miniSD 256 MB    | Transcend, Panasonic          |
| V1.0, V1.1  | miniSD 512 MB    | Transcend, Panasonic          |
| V1.0, V1.1  | miniSD 1 GB      | Transcend, Panasonic          |
| V2.0 SDHC CLASS 4   | miniSD 4 GB      | Transcend                     |
| V2.0 SDHC CLASS 6   | miniSD 4 GB      |                               |
| <ul style="list-style-type: none"> <li>- The DOS FAT file system is supported for the SD card.</li> <li>- Folders/files stored in the SD card should be in the 8.3 filename format</li> <li>- The miniSD/microSD card to SD card slot adapter is required.</li> </ul> |                  |                               |

**1.2 Interior View**

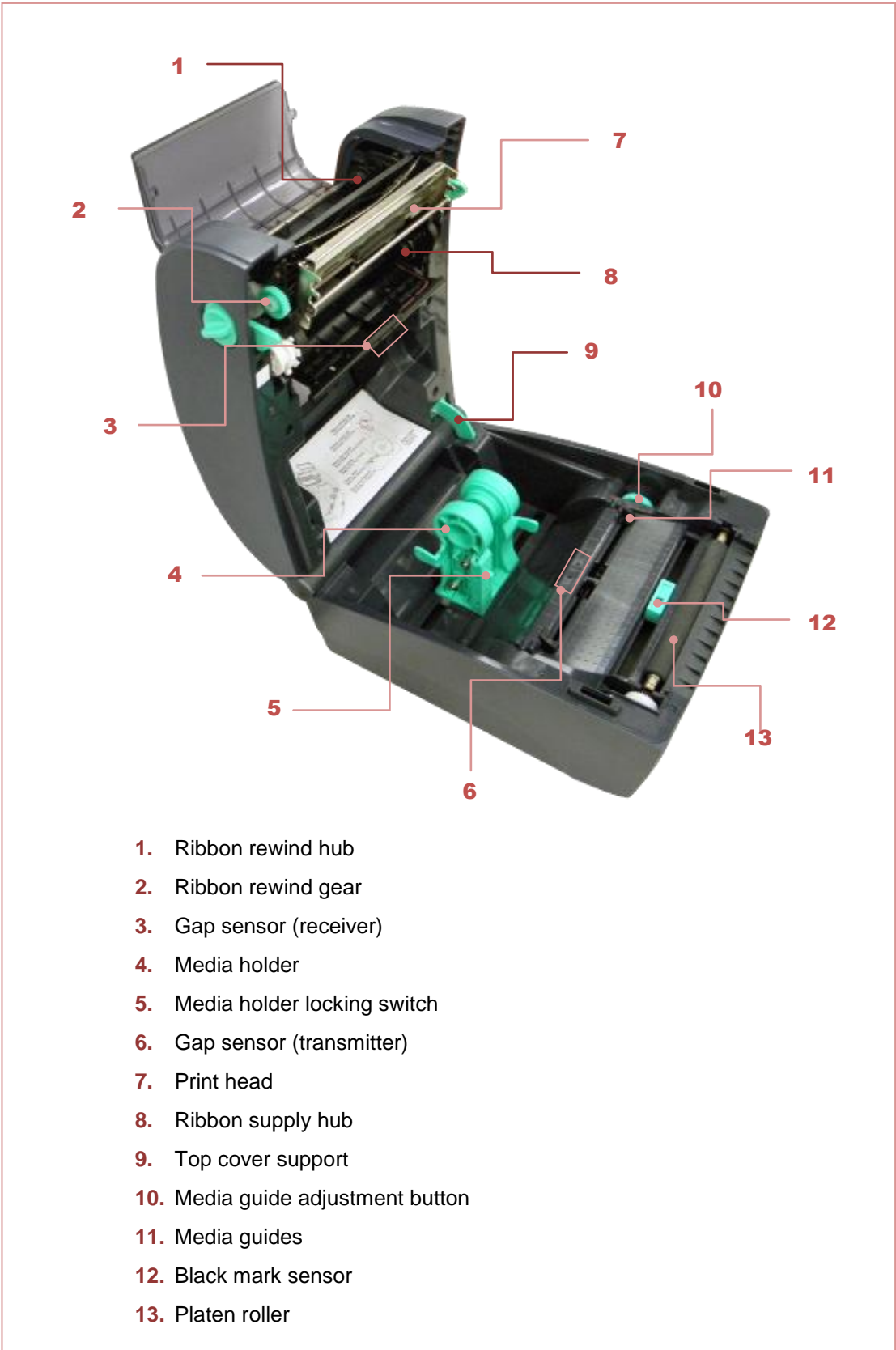

1.3 Rear View

For TC210 series

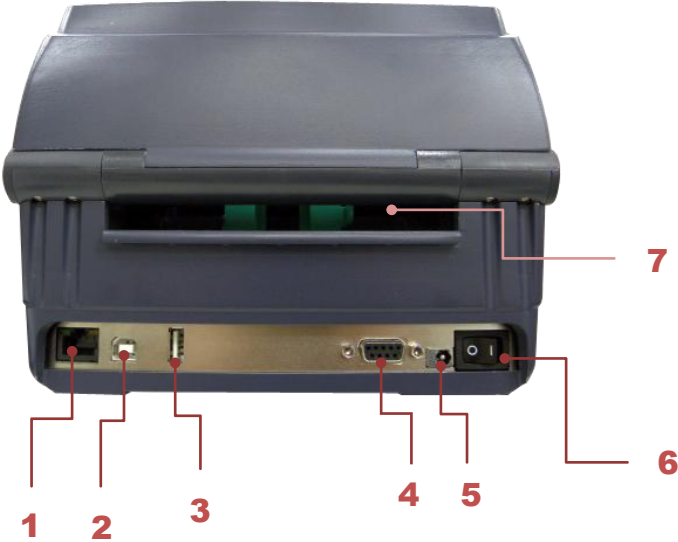

- 1. Ethernet interface
- 2. USB interface
- 3. USB host
- 4. RS-232C interface
- 5. Power jack socket
- 6. Power switch
- 7. External label entrance chute
- 8. Parallel interface

For TC200 series

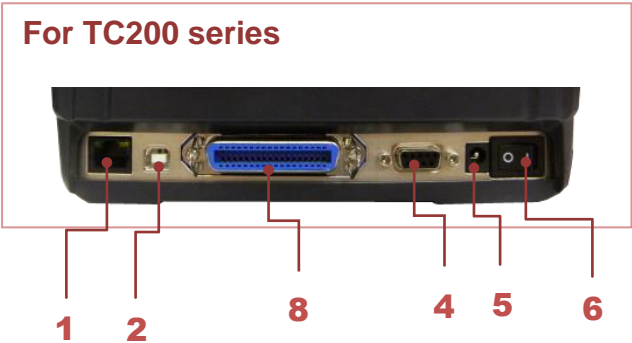

The interface picture here is for reference only. Please refer to the product specification for the interfaces availability.

## 2. ELECTRONICS

### 2.1 Summary of Board Connectors

For TC200/ TC300 Series

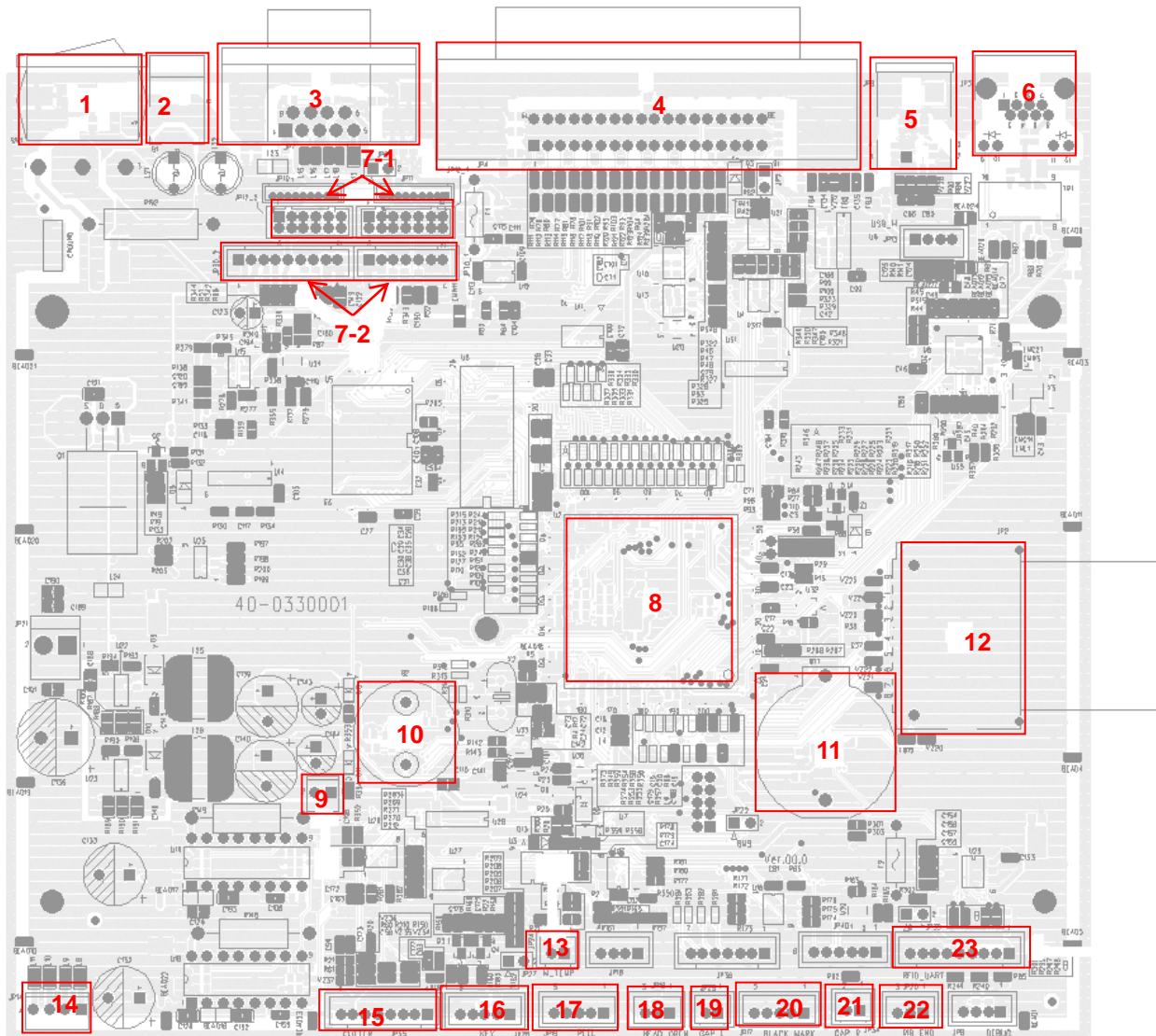

#### Main board





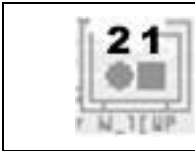

| Connector | Description                            | Remark |
|-----------|--|--------|
| 1         | Power switch                           | SW1    |
| 2         | Power supply output (24V DC) connector | B1     |
| 3         | RS-232C connector                      | JP7    |

# TC200/ TC300/ TC210/ TC310 Bar Code Printer Service Manual



| 4   | Centronics port connector   | JP4  |                               |  |         |   |                          |          |   |     |    |   |                  |  |   |               |                                    |   |                               |                                      |   |     |    |   |             |    |   |          |  |
|-----|---|--|-------------------------------|--|---------|---|--------------------------|----------|---|-----|----|---|------------------|--|---|---------------|------------------------------------|---|-------------------------------|--------------------------------------|---|-----|----|---|-------------|----|---|----------|--|
| 5   | USB connector   | JP9  |                               |  |         |   |                          |          |   |     |    |   |                  |  |   |               |                                    |   |                               |                                      |   |     |    |   |             |    |   |          |  |
| 6   | Ethernet connector  | JP3  |                               |  |         |   |                          |          |   |     |    |   |                  |  |   |               |                                    |   |                               |                                      |   |     |    |   |             |    |   |          |  |
| 7-1 | Print head connector (TTP-343C)   | JP12_1 & JP12_2  |                               |  |         |   |                          |          |   |     |    |   |                  |  |   |               |                                    |   |                               |                                      |   |     |    |   |             |    |   |          |  |
| 7-2 | Print head connector (TTP-245C / 244CE)   | JP30_1 & JP30_2  |                               |  |         |   |                          |          |   |     |    |   |                  |  |   |               |                                    |   |                               |                                      |   |     |    |   |             |    |   |          |  |
| 8   | Micro processor   | U2   |                               |  |         |   |                          |          |   |     |    |   |                  |  |   |               |                                    |   |                               |                                      |   |     |    |   |             |    |   |          |  |
| 9   | 5V DC connector   | JP22   |                               |  |         |   |                          |          |   |     |    |   |                  |  |   |               |                                    |   |                               |                                      |   |     |    |   |             |    |   |          |  |
| 10  | Buzzer (Factory option)   | B2   |                               |  |         |   |                          |          |   |     |    |   |                  |  |   |               |                                    |   |                               |                                      |   |     |    |   |             |    |   |          |  |
| 11  | RTC battery (Factory option)  | BT1  |                               |  |         |   |                          |          |   |     |    |   |                  |  |   |               |                                    |   |                               |                                      |   |     |    |   |             |    |   |          |  |
| 12  | SD card slot  | JP2  |                               |  |         |   |                          |          |   |     |    |   |                  |  |   |               |                                    |   |                               |                                      |   |     |    |   |             |    |   |          |  |
| 13  | Motor temp. thermistor connector  | JP24   |                               |  |         |   |                          |          |   |     |    |   |                  |  |   |               |                                    |   |                               |                                      |   |     |    |   |             |    |   |          |  |
|     |    | <table border="1"> <thead> <tr> <th>Pin</th> <th>Description</th> <th>Voltage</th> </tr> </thead> <tbody> <tr> <td>1</td> <td>Motor temp thermistor AD</td> <td>1.5~2.8V</td> </tr> <tr> <td>2</td> <td>GND</td> <td>0V</td> </tr> </tbody> </table>   | Pin                           | Description  | Voltage | 1 | Motor temp thermistor AD | 1.5~2.8V | 2 | GND | 0V |   |                  |  |   |               |                                    |   |                               |                                      |   |     |    |   |             |    |   |          |  |
|     |   | Pin  | Description                   | Voltage  |         |   |                          |          |   |     |    |   |                  |  |   |               |                                    |   |                               |                                      |   |     |    |   |             |    |   |          |  |
|     |   | 1  | Motor temp thermistor AD      | 1.5~2.8V   |         |   |                          |          |   |     |    |   |                  |  |   |               |                                    |   |                               |                                      |   |     |    |   |             |    |   |          |  |
| 2   | GND   | 0V   |                               |  |         |   |                          |          |   |     |    |   |                  |  |   |               |                                    |   |                               |                                      |   |     |    |   |             |    |   |          |  |
|     |   |  |                               |  |         |   |                          |          |   |     |    |   |                  |  |   |               |                                    |   |                               |                                      |   |     |    |   |             |    |   |          |  |
|     |   |  |                               |  |         |   |                          |          |   |     |    |   |                  |  |   |               |                                    |   |                               |                                      |   |     |    |   |             |    |   |          |  |
| 14  | Stepping motor connector  | JP14   |                               |  |         |   |                          |          |   |     |    |   |                  |  |   |               |                                    |   |                               |                                      |   |     |    |   |             |    |   |          |  |
| 15  | Cutter connector  | JP35   |                               |  |         |   |                          |          |   |     |    |   |                  |  |   |               |                                    |   |                               |                                      |   |     |    |   |             |    |   |          |  |
|     |  | <table border="1"> <thead> <tr> <th>Pin</th> <th>Description</th> <th>Voltage</th> </tr> </thead> <tbody> <tr> <td>1</td> <td>Cutter power</td> <td>24V</td> </tr> <tr> <td>2</td> <td>GND</td> <td>0V</td> </tr> <tr> <td>3</td> <td>Cutter direction</td> <td>0V: Cutter positive cut<br/>5V: Cutter negative cut</td> </tr> <tr> <td>4</td> <td>Cutter enable</td> <td>0V: Cutter work<br/>5V: Cutter stop</td> </tr> <tr> <td>5</td> <td>Cutter position sensor switch</td> <td>0V: Cutter stop<br/>3.3V: Cutter work</td> </tr> <tr> <td>6</td> <td>GND</td> <td>0V</td> </tr> <tr> <td>7</td> <td>Logic power</td> <td>5V</td> </tr> <tr> <td>8</td> <td>Reserved</td> <td></td> </tr> </tbody> </table> | Pin                           | Description  | Voltage | 1 | Cutter power             | 24V      | 2 | GND | 0V | 3 | Cutter direction | 0V: Cutter positive cut<br>5V: Cutter negative cut | 4 | Cutter enable | 0V: Cutter work<br>5V: Cutter stop | 5 | Cutter position sensor switch | 0V: Cutter stop<br>3.3V: Cutter work | 6 | GND | 0V | 7 | Logic power | 5V | 8 | Reserved |  |
|     |   | Pin  | Description                   | Voltage  |         |   |                          |          |   |     |    |   |                  |  |   |               |                                    |   |                               |                                      |   |     |    |   |             |    |   |          |  |
|     |   | 1  | Cutter power                  | 24V  |         |   |                          |          |   |     |    |   |                  |  |   |               |                                    |   |                               |                                      |   |     |    |   |             |    |   |          |  |
|     |   | 2  | GND                           | 0V   |         |   |                          |          |   |     |    |   |                  |  |   |               |                                    |   |                               |                                      |   |     |    |   |             |    |   |          |  |
|     |   | 3  | Cutter direction              | 0V: Cutter positive cut<br>5V: Cutter negative cut |         |   |                          |          |   |     |    |   |                  |  |   |               |                                    |   |                               |                                      |   |     |    |   |             |    |   |          |  |
|     |   | 4  | Cutter enable                 | 0V: Cutter work<br>5V: Cutter stop                 |         |   |                          |          |   |     |    |   |                  |  |   |               |                                    |   |                               |                                      |   |     |    |   |             |    |   |          |  |
|     |   | 5  | Cutter position sensor switch | 0V: Cutter stop<br>3.3V: Cutter work               |         |   |                          |          |   |     |    |   |                  |  |   |               |                                    |   |                               |                                      |   |     |    |   |             |    |   |          |  |
|     |   | 6  | GND                           | 0V   |         |   |                          |          |   |     |    |   |                  |  |   |               |                                    |   |                               |                                      |   |     |    |   |             |    |   |          |  |
|     | 7   | Logic power  | 5V                            |  |         |   |                          |          |   |     |    |   |                  |  |   |               |                                    |   |                               |                                      |   |     |    |   |             |    |   |          |  |
| 8   | Reserved  |  |                               |  |         |   |                          |          |   |     |    |   |                  |  |   |               |                                    |   |                               |                                      |   |     |    |   |             |    |   |          |  |
|     |   |  |                               |  |         |   |                          |          |   |     |    |   |                  |  |   |               |                                    |   |                               |                                      |   |     |    |   |             |    |   |          |  |
|     |   |  |                               |  |         |   |                          |          |   |     |    |   |                  |  |   |               |                                    |   |                               |                                      |   |     |    |   |             |    |   |          |  |
|     |   |  |                               |  |         |   |                          |          |   |     |    |   |                  |  |   |               |                                    |   |                               |                                      |   |     |    |   |             |    |   |          |  |
|     |   |  |                               |  |         |   |                          |          |   |     |    |   |                  |  |   |               |                                    |   |                               |                                      |   |     |    |   |             |    |   |          |  |
|     |   |  |                               |  |         |   |                          |          |   |     |    |   |                  |  |   |               |                                    |   |                               |                                      |   |     |    |   |             |    |   |          |  |
|     |   |  |                               |  |         |   |                          |          |   |     |    |   |                  |  |   |               |                                    |   |                               |                                      |   |     |    |   |             |    |   |          |  |
| 16  | Feed key and LED connector  | JP28   |                               |  |         |   |                          |          |   |     |    |   |                  |  |   |               |                                    |   |                               |                                      |   |     |    |   |             |    |   |          |  |



|    |   |  |                               |  |      |
|----|---|--|-------------------------------|--|------|
|    |    | <b>Pin</b>                                     | <b>Description</b>            | <b>Voltage</b>                                     |      |
|    |   | 1  | Power                         | 3.3V   |      |
|    |   | 2  | LED green                     | LED light on: 1.1~1.4V<br>LED light off: 1.6~1.9V  |      |
|    |   | 3  | LED red                       | LED light on : 1.4~1.7V<br>LED light off: 1.8~2.1V |      |
|    |   | 4  | Feed switch                   | 0V: Push key<br>3.3V: Stand-by                     |      |
|    |   | 5  | GND                           | 0V   |      |
| 17 |    | Peel-off sensor connector                      |                               |  | JP19 |
|    |   | <b>Pin</b>                                     | <b>Description</b>            | <b>Voltage</b>                                     |      |
|    |   | 1  |                               |  |      |
|    |   | 2  | Reserved                      |  |      |
|    |   | 3  | Peel sensor emitter           | Emitter on : 2.1~2.3V<br>Emitter off: 2.6~2.8V     |      |
|    |   | 4  | Peel sensor receiver AD       | 0~3.3V   |      |
| 5  | GND   | 0V   |                               |  |      |
| 18 |  | Head open sensor connector                     |                               |  | JP16 |
|    |   | <b>Pin</b>                                     | <b>Description</b>            | <b>Voltage</b>                                     |      |
|    |   | 1  | Power                         | 3.3V   |      |
|    |   | 2  | Head open sensor receiver     | 0~1.4V: Head close<br>1.7~3.3V: Head open          |      |
| 3  | GND   | 0V   |                               |  |      |
| 19 |  | Gap sensor emitter connector                   |                               |  | JP29 |
|    |   | <b>Pin</b>                                     | <b>Description</b>            | <b>Voltage</b>                                     |      |
|    |   | 1  | Power                         | 3.3V   |      |
| 2  | Gap sensor emitter  | Emitter on : 2.1~2.3V<br>Emitter off: 2.6~2.8V |                               |  |      |
| 20 |  | Black mark sensor connector                    |                               |  | JP17 |
|    |   | <b>Pin</b>                                     | <b>Description</b>            | <b>Voltage</b>                                     |      |
|    |   | 1  | Not use                       |  |      |
|    |   | 2  | Power                         | 3.3V   |      |
|    |   | 3  | Black mark sensor emitter     | Emitter on : 2.1~2.3V<br>Emitter off: 2.6~2.8V     |      |
|    |   | 4  | Black mark sensor receiver AD | 0~3.3V   |      |
| 5  | Power   | 3.3V   |                               |  |      |

# TC200/ TC300/ TC210/ TC310 Bar Code Printer Service Manual



|    |   |        |             |         |
|----|---|--------|-------------|---------|
| 21 | Gap sensor receiver connector   |        | JP34        |         |
|    |  | Pin    | Description | Voltage |
|    |   | 1      | Power       | 3.3V    |
| 2  | Gap sensor receiver AD  | 0~3.3V |             |         |
| 22 | Ribbon encoder sensor connector   |        | JP20        |         |
| 23 | RFID module connector (Factory option)  |        | JP38        |         |

## Main board bottom

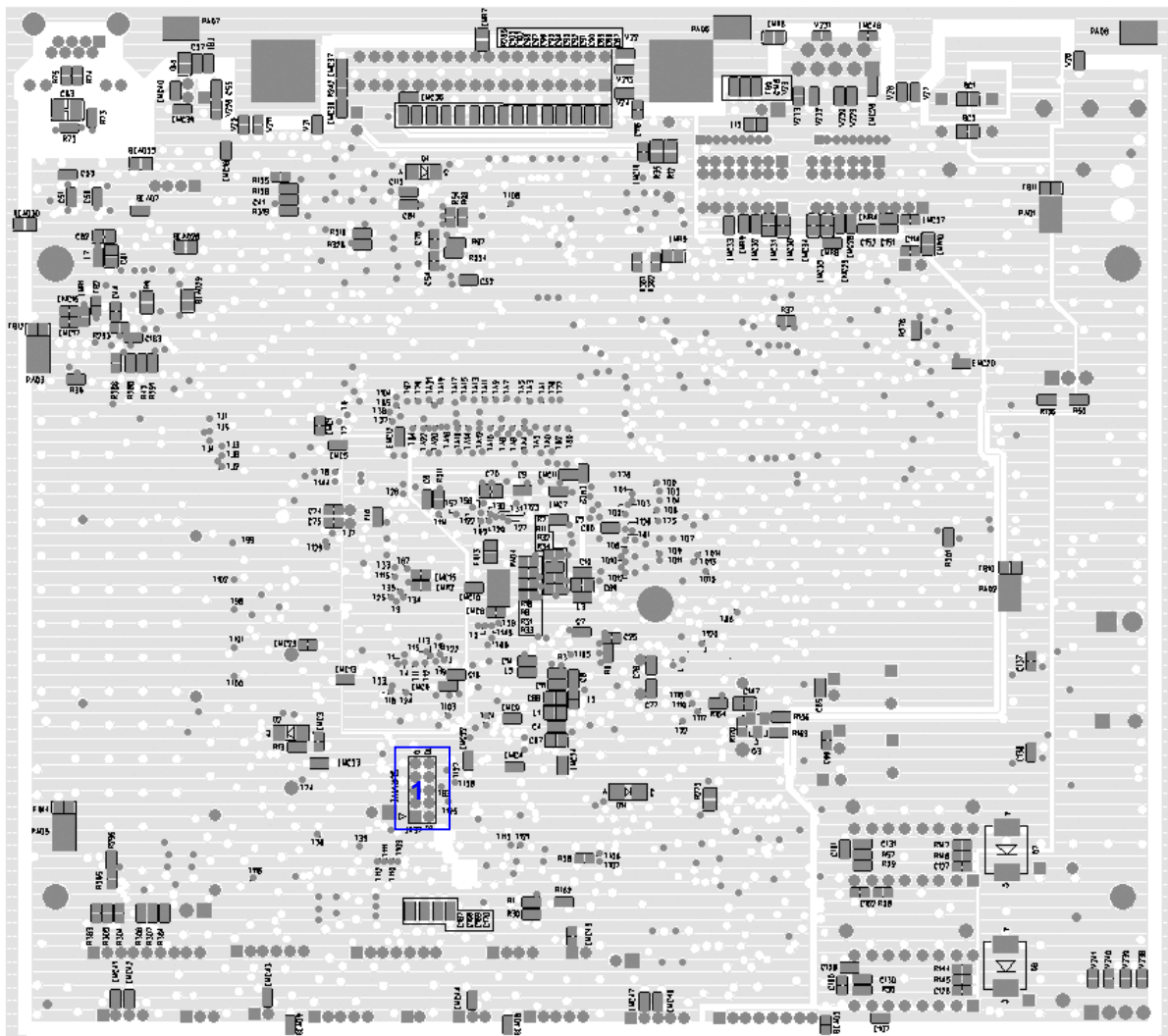

| Connector | Description                     | Remark |
|-----------|---------------------------------|--------|
| 1         | Firmware recover card connector | JP37   |

# TC200/ TC300/ TC210/ TC310 Bar Code Printer Service Manual



**For TC210/ TC310 Series**

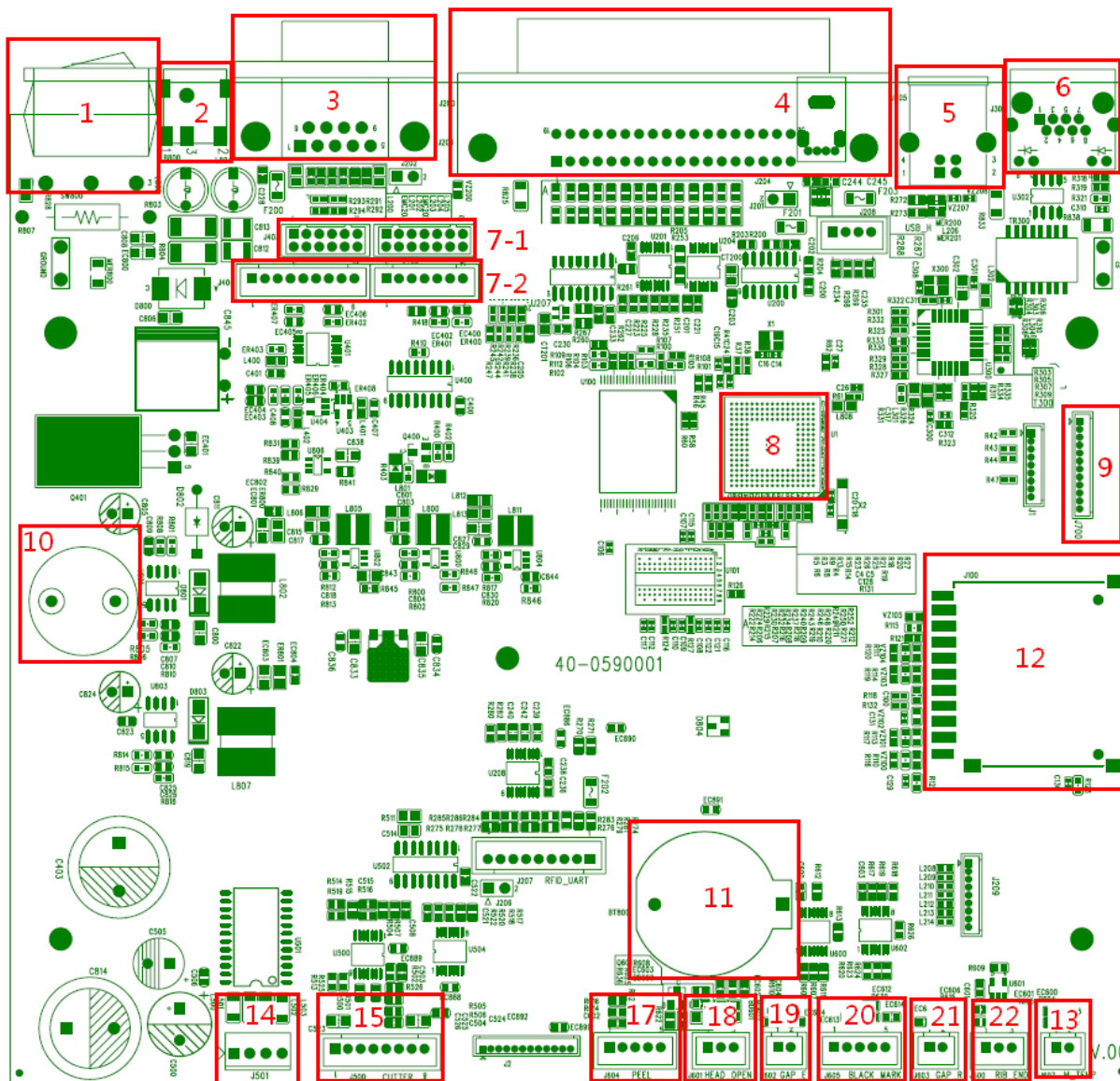

## Main board







| Connector | Description  | Remark      |
|-----------|--|-------------|
| 1         | Power switch   | SW800       |
| 2         | Power supply output (24V DC) connector                 | B800        |
| 3         | RS-232C connector                                      | J203        |
| 4         | USB host connector/ Centronics port connector (Option) | J204 / J200 |
| 5         | USB connector  | J205        |
| 6         | Ethernet connector                                     | J300        |

# TC200/ TC300/ TC210/ TC310 Bar Code Printer Service Manual



| 7-1 | Print head connector (TC310)  | J401 & J403  |                               |  |         |   |                          |          |   |          |    |   |                     |  |   |                         |                                    |   |                               |                                      |   |     |    |   |             |    |   |          |  |  |
|-----|---|--|-------------------------------|--|---------|---|--------------------------|----------|---|----------|----|---|---------------------|--|---|-------------------------|------------------------------------|---|-------------------------------|--------------------------------------|---|-----|----|---|-------------|----|---|----------|--|--|
| 7-2 | Print head connector (TC210)  | J402 & J404  |                               |  |         |   |                          |          |   |          |    |   |                     |  |   |                         |                                    |   |                               |                                      |   |     |    |   |             |    |   |          |  |  |
| 8   | Micro processor   | U1   |                               |  |         |   |                          |          |   |          |    |   |                     |  |   |                         |                                    |   |                               |                                      |   |     |    |   |             |    |   |          |  |  |
| 9   | LCD MODULE connector  | J700   |                               |  |         |   |                          |          |   |          |    |   |                     |  |   |                         |                                    |   |                               |                                      |   |     |    |   |             |    |   |          |  |  |
| 10  | Buzzer (Factory option)   | B600   |                               |  |         |   |                          |          |   |          |    |   |                     |  |   |                         |                                    |   |                               |                                      |   |     |    |   |             |    |   |          |  |  |
| 11  | RTC battery (Factory option)  | BT800  |                               |  |         |   |                          |          |   |          |    |   |                     |  |   |                         |                                    |   |                               |                                      |   |     |    |   |             |    |   |          |  |  |
| 12  | SD card slot  | J100   |                               |  |         |   |                          |          |   |          |    |   |                     |  |   |                         |                                    |   |                               |                                      |   |     |    |   |             |    |   |          |  |  |
| 13  | Motor temp. thermistor connector  |  | J607                          |  |         |   |                          |          |   |          |    |   |                     |  |   |                         |                                    |   |                               |                                      |   |     |    |   |             |    |   |          |  |  |
|     |    | <table border="1"> <thead> <tr> <th>Pin</th> <th>Description</th> <th>Voltage</th> </tr> </thead> <tbody> <tr> <td>1</td> <td>Motor temp thermistor AD</td> <td>1.5~2.8V</td> </tr> <tr> <td>2</td> <td>GND</td> <td>0V</td> </tr> </tbody> </table>   | Pin                           | Description  | Voltage | 1 | Motor temp thermistor AD | 1.5~2.8V | 2 | GND      | 0V |   |                     |  |   |                         |                                    |   |                               |                                      |   |     |    |   |             |    |   |          |  |  |
|     |   | Pin  | Description                   | Voltage  |         |   |                          |          |   |          |    |   |                     |  |   |                         |                                    |   |                               |                                      |   |     |    |   |             |    |   |          |  |  |
| 1   | Motor temp thermistor AD  | 1.5~2.8V   |                               |  |         |   |                          |          |   |          |    |   |                     |  |   |                         |                                    |   |                               |                                      |   |     |    |   |             |    |   |          |  |  |
| 2   | GND   | 0V   |                               |  |         |   |                          |          |   |          |    |   |                     |  |   |                         |                                    |   |                               |                                      |   |     |    |   |             |    |   |          |  |  |
|     |   |  |                               |  |         |   |                          |          |   |          |    |   |                     |  |   |                         |                                    |   |                               |                                      |   |     |    |   |             |    |   |          |  |  |
| 14  | Stepping motor connector  | J501   |                               |  |         |   |                          |          |   |          |    |   |                     |  |   |                         |                                    |   |                               |                                      |   |     |    |   |             |    |   |          |  |  |
| 15  | Cutter connector  |  | J500                          |  |         |   |                          |          |   |          |    |   |                     |  |   |                         |                                    |   |                               |                                      |   |     |    |   |             |    |   |          |  |  |
|     |  | <table border="1"> <thead> <tr> <th>Pin</th> <th>Description</th> <th>Voltage</th> </tr> </thead> <tbody> <tr> <td>1</td> <td>Cutter power</td> <td>24V</td> </tr> <tr> <td>2</td> <td>GND</td> <td>0V</td> </tr> <tr> <td>3</td> <td>Cutter direction</td> <td>0V: Cutter positive cut<br/>5V: Cutter negative cut</td> </tr> <tr> <td>4</td> <td>Cutter enable</td> <td>0V: Cutter work<br/>5V: Cutter stop</td> </tr> <tr> <td>5</td> <td>Cutter position sensor switch</td> <td>0V: Cutter stop<br/>3.3V: Cutter work</td> </tr> <tr> <td>6</td> <td>GND</td> <td>0V</td> </tr> <tr> <td>7</td> <td>Logic power</td> <td>5V</td> </tr> <tr> <td>8</td> <td>Reserved</td> <td></td> </tr> </tbody> </table> | Pin                           | Description  | Voltage | 1 | Cutter power             | 24V      | 2 | GND      | 0V | 3 | Cutter direction    | 0V: Cutter positive cut<br>5V: Cutter negative cut | 4 | Cutter enable           | 0V: Cutter work<br>5V: Cutter stop | 5 | Cutter position sensor switch | 0V: Cutter stop<br>3.3V: Cutter work | 6 | GND | 0V | 7 | Logic power | 5V | 8 | Reserved |  |  |
|     |   | Pin  | Description                   | Voltage  |         |   |                          |          |   |          |    |   |                     |  |   |                         |                                    |   |                               |                                      |   |     |    |   |             |    |   |          |  |  |
|     |   | 1  | Cutter power                  | 24V  |         |   |                          |          |   |          |    |   |                     |  |   |                         |                                    |   |                               |                                      |   |     |    |   |             |    |   |          |  |  |
|     |   | 2  | GND                           | 0V   |         |   |                          |          |   |          |    |   |                     |  |   |                         |                                    |   |                               |                                      |   |     |    |   |             |    |   |          |  |  |
|     |   | 3  | Cutter direction              | 0V: Cutter positive cut<br>5V: Cutter negative cut |         |   |                          |          |   |          |    |   |                     |  |   |                         |                                    |   |                               |                                      |   |     |    |   |             |    |   |          |  |  |
|     |   | 4  | Cutter enable                 | 0V: Cutter work<br>5V: Cutter stop                 |         |   |                          |          |   |          |    |   |                     |  |   |                         |                                    |   |                               |                                      |   |     |    |   |             |    |   |          |  |  |
|     |   | 5  | Cutter position sensor switch | 0V: Cutter stop<br>3.3V: Cutter work               |         |   |                          |          |   |          |    |   |                     |  |   |                         |                                    |   |                               |                                      |   |     |    |   |             |    |   |          |  |  |
|     |   | 6  | GND                           | 0V   |         |   |                          |          |   |          |    |   |                     |  |   |                         |                                    |   |                               |                                      |   |     |    |   |             |    |   |          |  |  |
| 7   | Logic power   | 5V   |                               |  |         |   |                          |          |   |          |    |   |                     |  |   |                         |                                    |   |                               |                                      |   |     |    |   |             |    |   |          |  |  |
| 8   | Reserved  |  |                               |  |         |   |                          |          |   |          |    |   |                     |  |   |                         |                                    |   |                               |                                      |   |     |    |   |             |    |   |          |  |  |
|     |   |  |                               |  |         |   |                          |          |   |          |    |   |                     |  |   |                         |                                    |   |                               |                                      |   |     |    |   |             |    |   |          |  |  |
|     |   |  |                               |  |         |   |                          |          |   |          |    |   |                     |  |   |                         |                                    |   |                               |                                      |   |     |    |   |             |    |   |          |  |  |
|     |   |  |                               |  |         |   |                          |          |   |          |    |   |                     |  |   |                         |                                    |   |                               |                                      |   |     |    |   |             |    |   |          |  |  |
|     |   |  |                               |  |         |   |                          |          |   |          |    |   |                     |  |   |                         |                                    |   |                               |                                      |   |     |    |   |             |    |   |          |  |  |
|     |   |  |                               |  |         |   |                          |          |   |          |    |   |                     |  |   |                         |                                    |   |                               |                                      |   |     |    |   |             |    |   |          |  |  |
|     |   |  |                               |  |         |   |                          |          |   |          |    |   |                     |  |   |                         |                                    |   |                               |                                      |   |     |    |   |             |    |   |          |  |  |
| 17  | Peel-off sensor connector   |  | J604                          |  |         |   |                          |          |   |          |    |   |                     |  |   |                         |                                    |   |                               |                                      |   |     |    |   |             |    |   |          |  |  |
|     |  | <table border="1"> <thead> <tr> <th>Pin</th> <th>Description</th> <th>Voltage</th> </tr> </thead> <tbody> <tr> <td>1</td> <td></td> <td></td> </tr> <tr> <td>2</td> <td>Reserved</td> <td></td> </tr> <tr> <td>3</td> <td>Peel sensor emitter</td> <td>Emitter on : 2.1~2.3V<br/>Emitter off: 2.6~2.8V</td> </tr> <tr> <td>4</td> <td>Peel sensor receiver AD</td> <td>0~3.3V</td> </tr> <tr> <td>5</td> <td>GND</td> <td>0V</td> </tr> </tbody> </table>  | Pin                           | Description  | Voltage | 1 |                          |          | 2 | Reserved |    | 3 | Peel sensor emitter | Emitter on : 2.1~2.3V<br>Emitter off: 2.6~2.8V     | 4 | Peel sensor receiver AD | 0~3.3V                             | 5 | GND                           | 0V                                   |   |     |    |   |             |    |   |          |  |  |
|     |   | Pin  | Description                   | Voltage  |         |   |                          |          |   |          |    |   |                     |  |   |                         |                                    |   |                               |                                      |   |     |    |   |             |    |   |          |  |  |
|     |   | 1  |                               |  |         |   |                          |          |   |          |    |   |                     |  |   |                         |                                    |   |                               |                                      |   |     |    |   |             |    |   |          |  |  |
|     |   | 2  | Reserved                      |  |         |   |                          |          |   |          |    |   |                     |  |   |                         |                                    |   |                               |                                      |   |     |    |   |             |    |   |          |  |  |
| 3   | Peel sensor emitter   | Emitter on : 2.1~2.3V<br>Emitter off: 2.6~2.8V   |                               |  |         |   |                          |          |   |          |    |   |                     |  |   |                         |                                    |   |                               |                                      |   |     |    |   |             |    |   |          |  |  |
| 4   | Peel sensor receiver AD   | 0~3.3V   |                               |  |         |   |                          |          |   |          |    |   |                     |  |   |                         |                                    |   |                               |                                      |   |     |    |   |             |    |   |          |  |  |
| 5   | GND   | 0V   |                               |  |         |   |                          |          |   |          |    |   |                     |  |   |                         |                                    |   |                               |                                      |   |     |    |   |             |    |   |          |  |  |
|     |   |  |                               |  |         |   |                          |          |   |          |    |   |                     |  |   |                         |                                    |   |                               |                                      |   |     |    |   |             |    |   |          |  |  |
|     |   |  |                               |  |         |   |                          |          |   |          |    |   |                     |  |   |                         |                                    |   |                               |                                      |   |     |    |   |             |    |   |          |  |  |
|     |   |  |                               |  |         |   |                          |          |   |          |    |   |                     |  |   |                         |                                    |   |                               |                                      |   |     |    |   |             |    |   |          |  |  |
|     |   |  |                               |  |         |   |                          |          |   |          |    |   |                     |  |   |                         |                                    |   |                               |                                      |   |     |    |   |             |    |   |          |  |  |

|    |   |            |                               |  |
|----|---|------------|-------------------------------|--|
| 18 | Head open sensor connector  |            | J601                          |  |
|    |    | <b>Pin</b> | <b>Description</b>            | <b>Voltage</b>                                 |
|    |   | 1          | Power                         | 3.3V   |
|    |   | 2          | Head open sensor receiver     | 0~1.4V: Head close<br>1.7~3.3V: Head open      |
|    | 3   | GND        | 0V                            |  |
| 19 | Gap sensor emitter connector  |            | J602                          |  |
|    |    | <b>Pin</b> | <b>Description</b>            | <b>Voltage</b>                                 |
|    |   | 1          | Power                         | 3.3V   |
|    |   | 2          | Gap sensor emitter            | Emitter on : 2.1~2.3V<br>Emitter off: 2.6~2.8V |
| 20 | Black mark sensor connector   |            | J605                          |  |
|    |  | <b>Pin</b> | <b>Description</b>            | <b>Voltage</b>                                 |
|    |   | 1          | Not use                       |  |
|    |   | 2          | Power                         | 3.3V   |
|    |   | 3          | Black mark sensor emitter     | Emitter on : 2.1~2.3V<br>Emitter off: 2.6~2.8V |
|    |   | 4          | Black mark sensor receiver AD | 0~3.3V   |
| 5  | Power   | 3.3V       |                               |  |
| 21 | Gap sensor receiver connector   |            | J603                          |  |
|    |  | <b>Pin</b> | <b>Description</b>            | <b>Voltage</b>                                 |
|    |   | 1          | Power                         | 3.3V   |
|    |   | 2          | Gap sensor receiver AD        | 0~3.3V   |
| 22 | Ribbon encoder sensor connector   |            | J600                          |  |
| 23 | RFID module connector (Factory option)  |            | J207                          |  |

## 2.2 Pin Configuration

### RS-232C

| PIN | CONFIGURATION |
|-----|---------------|
| 1   | +5 V          |
| 2   | TXD           |
| 3   | RXD           |
| 4   | CTS           |
| 5   | GND           |
| 6   | RTS           |
| 7   | N/C           |
| 8   | RTS           |
| 9   | N/C           |

### USB

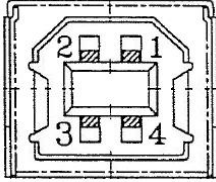
|   | PIN | CONFIGURATION |
|---|-----|---------------|
|  | 1   | N/C           |
|   | 2   | D-            |
|   | 3   | D+            |
|   | 4   | GND           |

### Centronics

| Pin | SPP Mode | Nibble | In/Out | Function  |
|-----|----------|--------|--------|---|
| 1   | Strobe   | N/A    | In     | A <b>low</b> on this line indicates that there are valid data at the host. When this pin is de-asserted, the +ve clock edge should be used to shift the data into the device. |
| 2-9 | Data 0-7 | N/A    | In     | Data Bus. Single-directional.   |
| 10  | Ack      | N/A    | Out    | A <b>low</b> on this line indicates that there are valid data at the Device. When this pin is de-asserted, the +ve clock edge should be used to shift the data into the host. |
| 11  | Busy     | N/A    | Out    | When in reverse direction, a <b>high</b> indicates data, while a <b>low</b> indicates a command cycle. In forward   |

# TC200/ TC300/ TC210/ TC310 Bar Code Printer Service Manual



|       |                 |     |     |   |
|-------|-----------------|-----|-----|---|
|       |                 |     |     | direction, it functions as PtrBusy.   |
| 12    | Paper Out / End | N/A | Out | When <b>low</b> , device acknowledges reverse request.                      |
| 13    | Select          | N/A | Out | Extensibility flag  |
| 14    | Ground          | N/A | GND | Ground  |
| 15    | No Defined      | N/A | N/A |   |
| 16-17 | Ground          | N/A | GND | Ground  |
| 18    | No Defined      | N/A | N/A |   |
| 19-30 | Ground          | N/A | GND | Ground  |
| 31    | No Defined      | N/A | N/A |   |
| 32    | Error / Fault   | N/A | Out | A <b>low</b> set by the device indicates that the reverse data is available |
| 33-35 | Ground          | N/A | GND | Ground  |
| 36    | No Defined      | N/A | N/A |   |



## Ethernet

| PIN | CONFIGURATION |
|-----|---------------|
| 1   | <b>Tx+</b>    |
| 2   | <b>Tx-</b>    |
| 3   | <b>Rx+</b>    |
| 4   | <b>N/C</b>    |
| 5   | <b>N/C</b>    |
| 6   | <b>Rx-</b>    |
| 7   | <b>N/C</b>    |
| 8   | <b>N/C</b>    |

### 3. MECHANISM

Please turn off the power switch and unplug the power adapter before replacing parts.

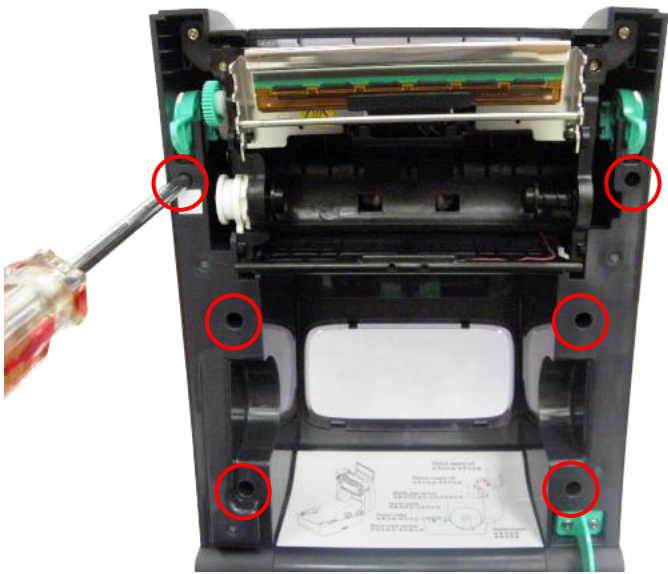
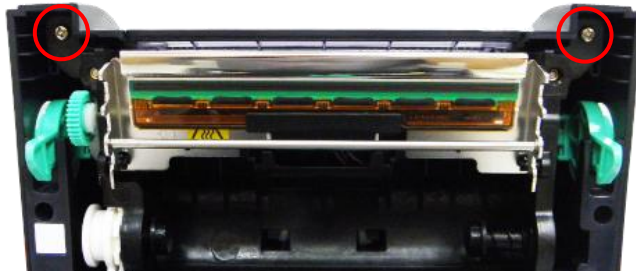
#### 3.1 Replacing LED (Or LCD) Module

|   |   |
|---|---|
|  A photograph of the printer's top cover with the top inner cover removed. A screwdriver is shown on the left, and six screws are circled in red to indicate they need to be removed. | <p>1. Open the printer top cover.<br/>Remove 6 screws from the top inner cover.</p> |
|  A photograph of the printer's top cover with the top inner cover removed. Two screws are circled in red to indicate they need to be removed.  | <p>2. Remove 2 screws that hold the print head bracket.</p>                         |
|  A photograph of the printer's top cover with the top inner cover removed. The harness is disconnected from the LCD (or LED) PCB.  | <p>3. Disconnect the harness from the LCD (or LED) PCB to remove the top cover.</p> |



4. Remove 5 screws to replace the LCD module. (Or remove 2 screws to replace the LED module.) Reassemble the parts in the reverse procedure.

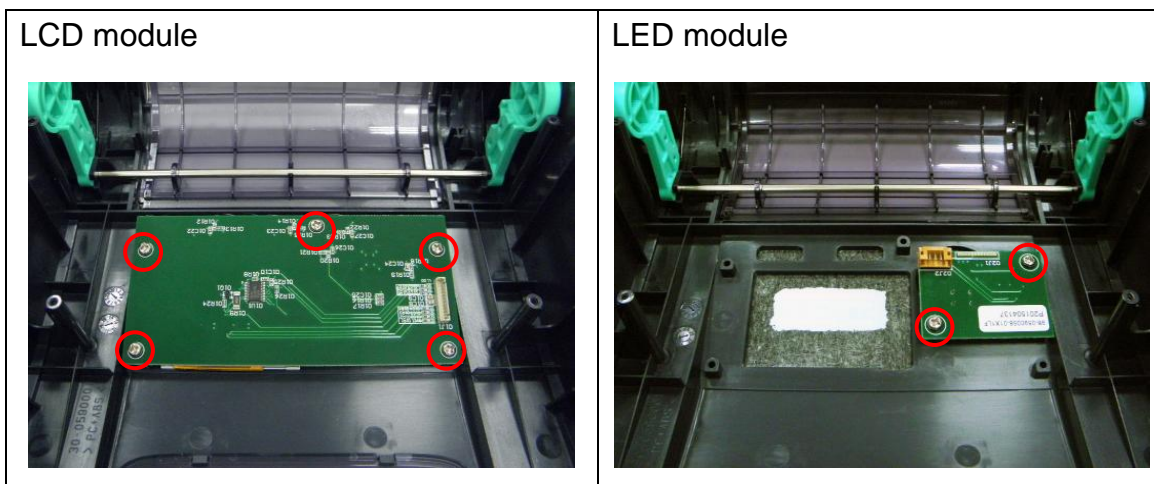

### 3.2 Replacing the Main Board

1. Turn the printer upside down and use the Phillips screwdriver to remove 6 screws on lower cover. Remove the lower cover.

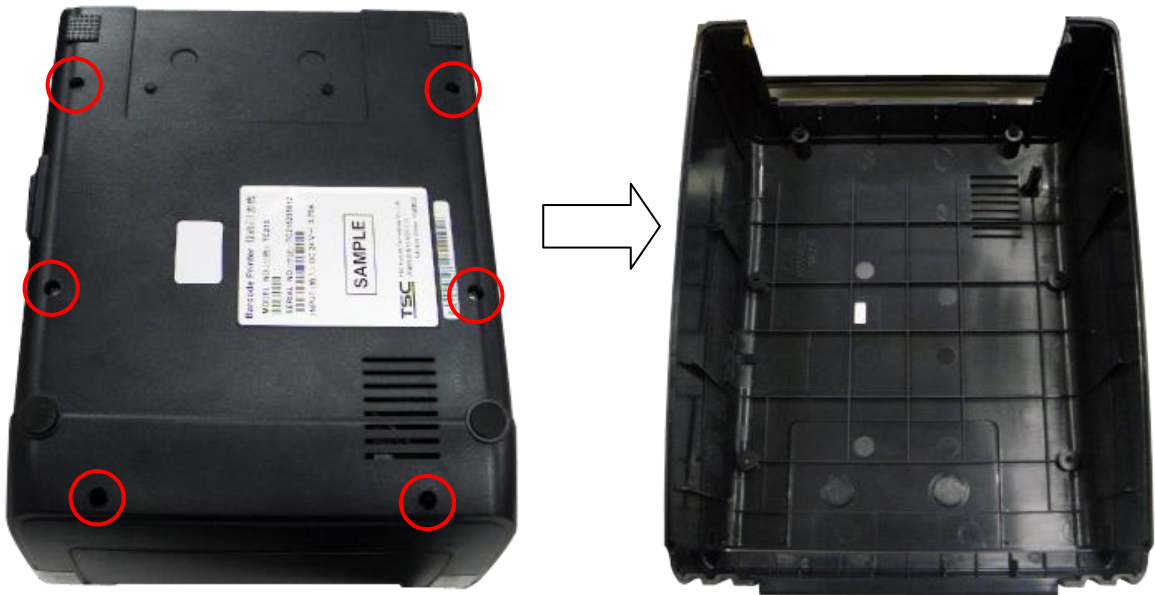

2. Remove 1 screw on the main board.
3. Disconnect all connectors to replace main board.



4. Reassemble the parts in the reverse procedures.

### 3.3 Replacing the Head Open Sensor

---

1. Refer to section 3.2 to remove the lower cover.
2. Disconnect the connector on the main board.

**Note:**

**The connector located on J601 for TC210/TC310 series.**

**The connector located on JP16 for TC200/TC300 series.**

3. Remove 1 screw on the head open sensor PCB.

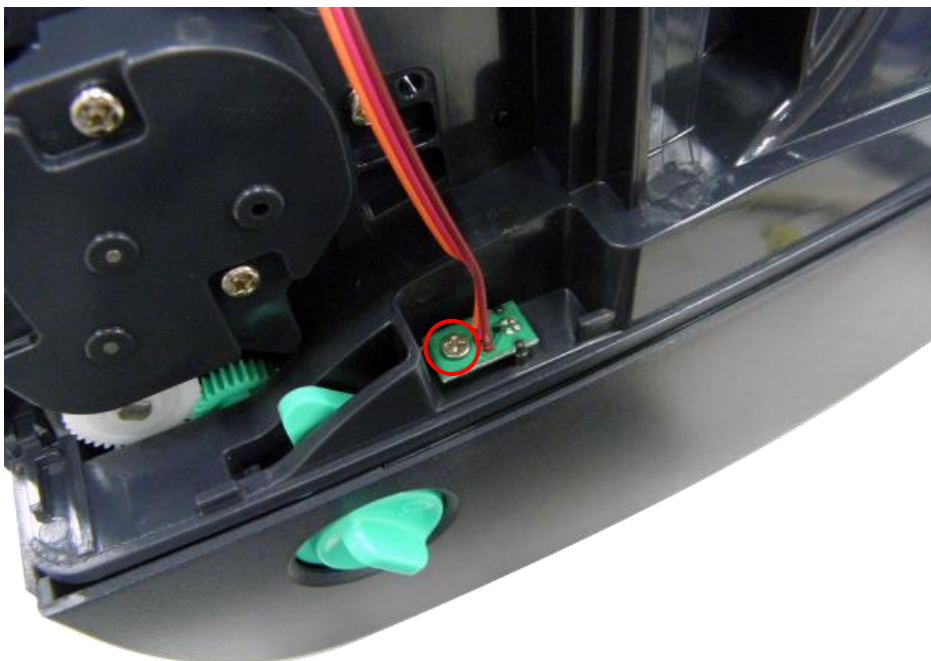

4. Reassemble the parts in the reverse procedures.
-

### 3.4 Replacing the Platen Roller Assembly

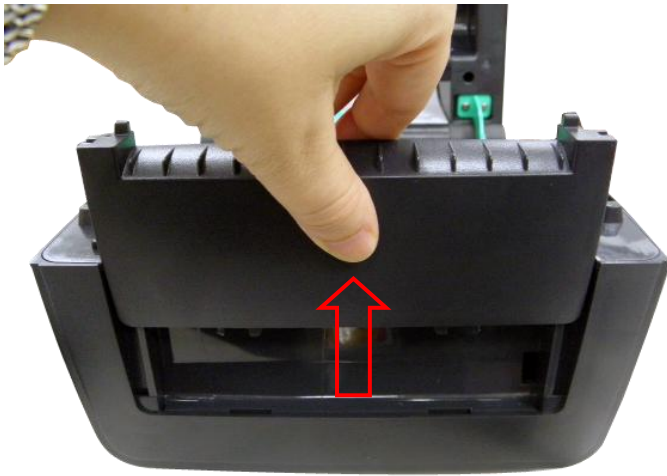

1. Open the printer top cover to remove the front panel.

2. Disengage the platen holder tabs to the lower inner cover by pulling out the right side and left side tabs toward the center of platen and rotates 90 degrees.

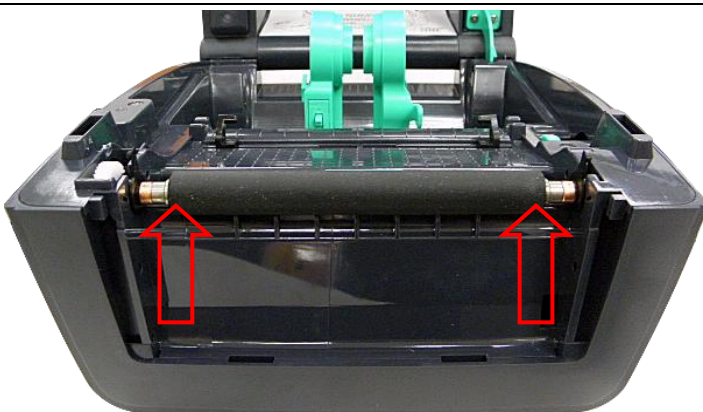
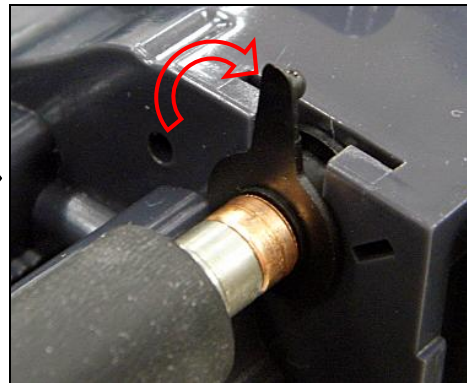
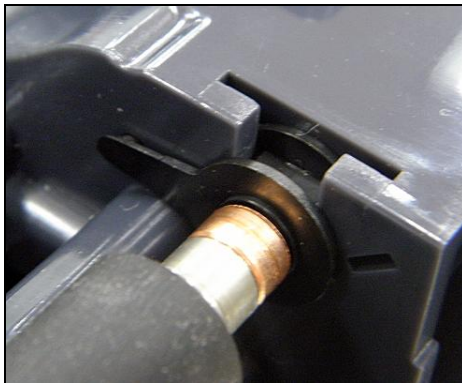



3. Take out the platen roller assembly and replace a new platen roller assembly.

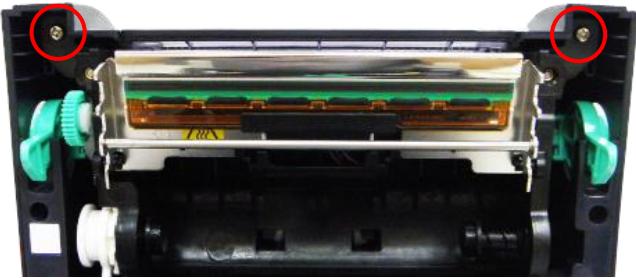
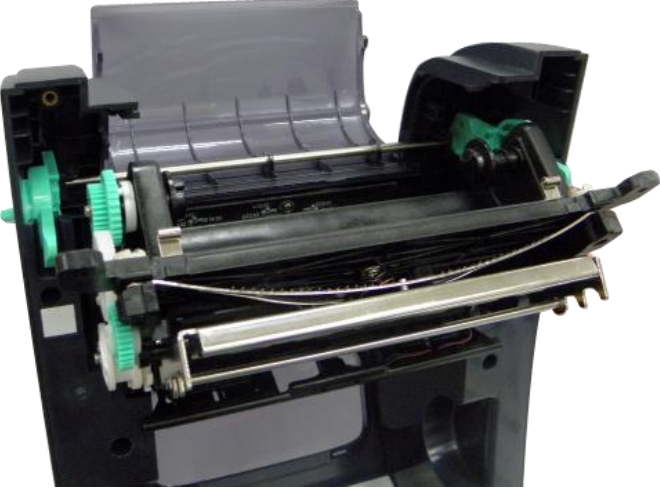
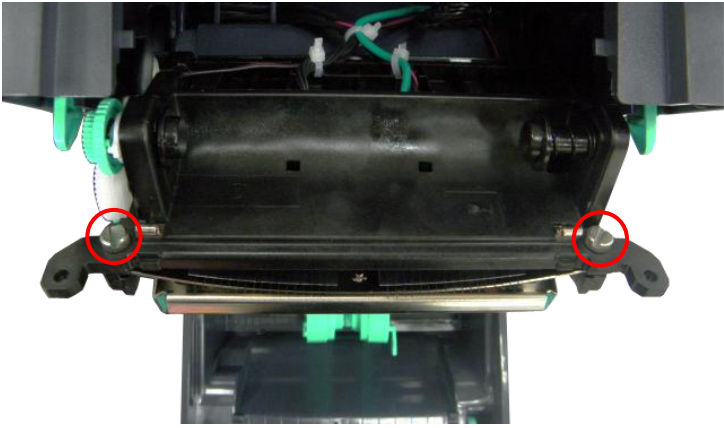

4. Reassemble the parts in the reverse procedures.

### 3.5 Replacing the Print Head Assembly

|   |  |
|---|--|
|    | <ol style="list-style-type: none"><li>1. Open the printer top cover.</li><li>2. Remove 2 screws that hold the print head bracket.</li></ol>  |
|   | <ol style="list-style-type: none"><li>3. Open the ribbon access cover. Let print head bracket drops into its place.</li></ol>  |
|  | <ol style="list-style-type: none"><li>4. Use the slotted screwdriver to remove 2 screws that fix the print head spring plate.</li></ol>  |
|  | <ol style="list-style-type: none"><li>5. Pull the print head module forward to take out the module and disconnect the print head harness. Remove/ Replace the print head assembly.</li></ol> |

6. Remove the print head harness cover to connect the print head harness for new print head module then install back the cover.

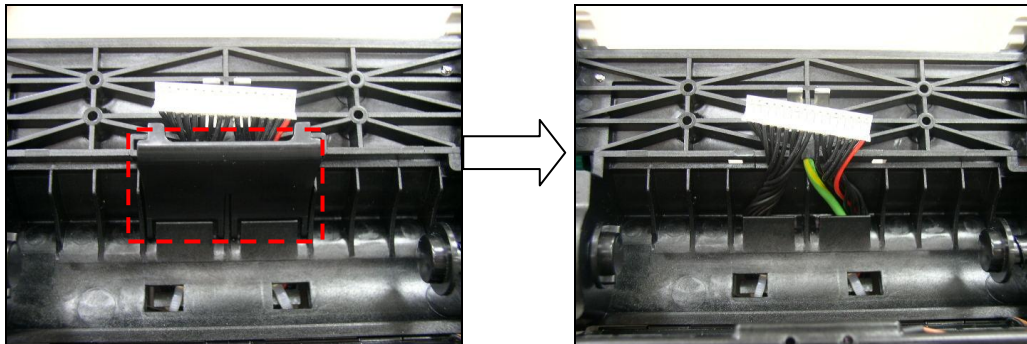

7. Insert the new print head module spring plate into the ribbon base print head spring plate slot. **Make sure the TPH bracket hinge slots are engaged with the hinges at both sides.** Reassemble the parts in the reverse procedures.

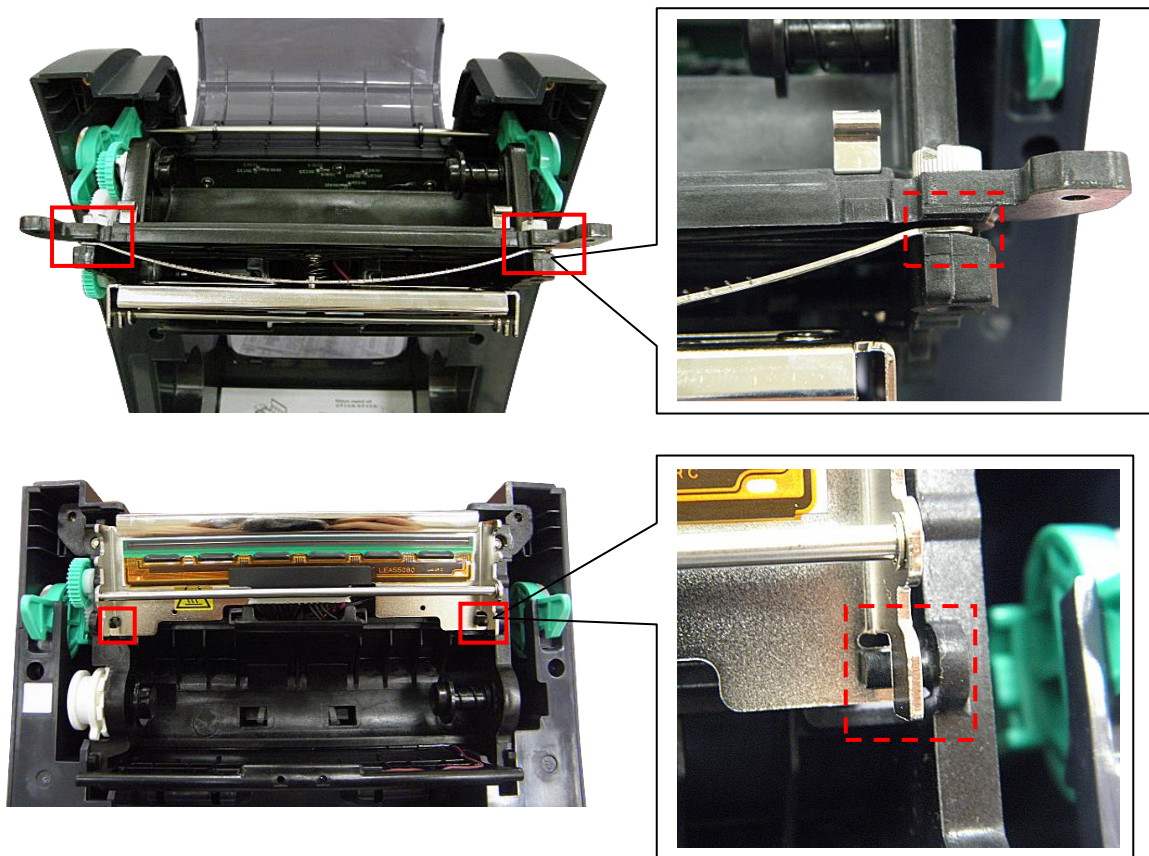

**Note:**

There is static brush adhered on the print head spring plate. The static brush free end side is toward the paper feed direction.

## 3.6 Replacing the Stepping Motor

1. Refer to section 3.2 to remove the lower cover.
2. Disconnect the stepping motor connector from the main board.

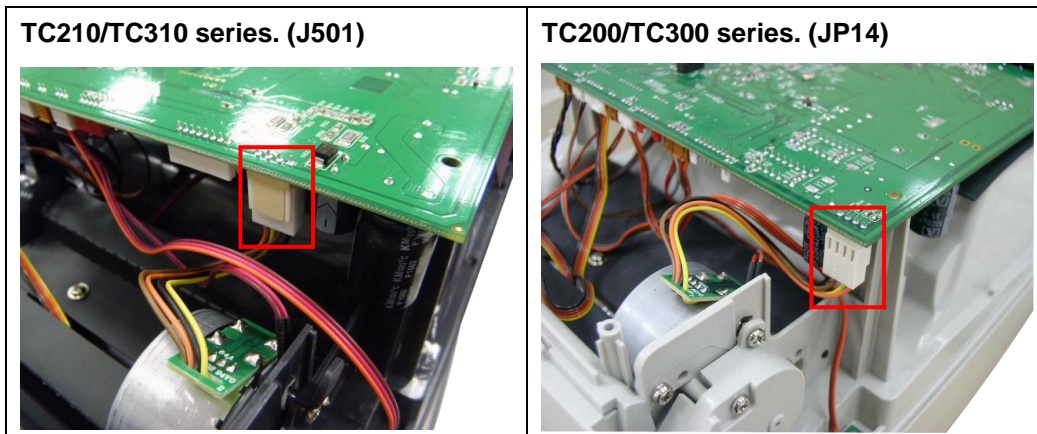

3. Remove 2 screws to replace stepping motor.

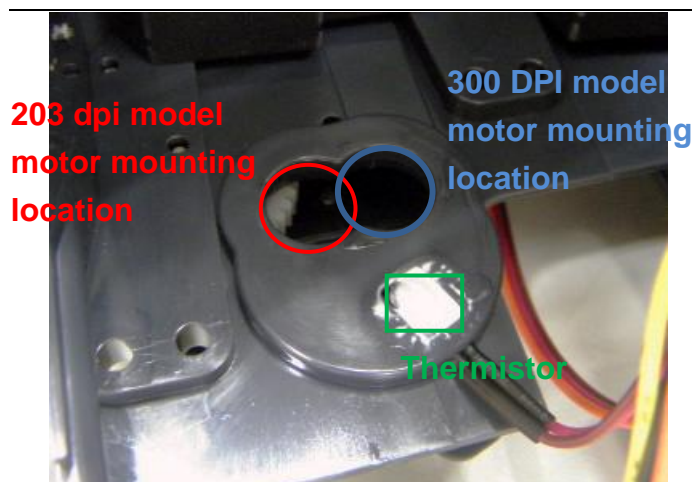
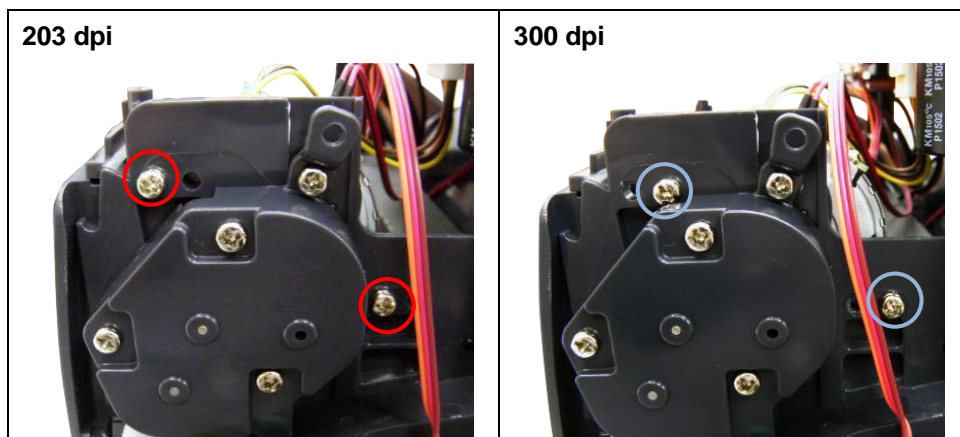

4. Make sure the new stepping motor is mounted at the correct location and thermistor is applied with the thermal conductive grease to keep good contact with stepping motor case.
5. Reassemble the parts in the reverse procedures.

### 3.7 Replacing the Black-mark Sensor Module

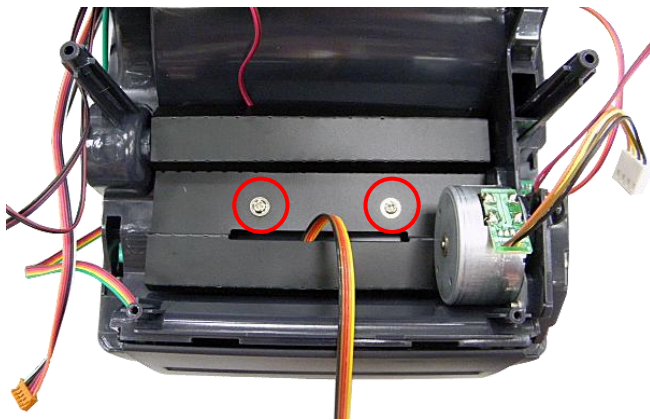

1. Refer to section 3.2 to remove the main board.
2. Remove 2 screws to release the black mylar.

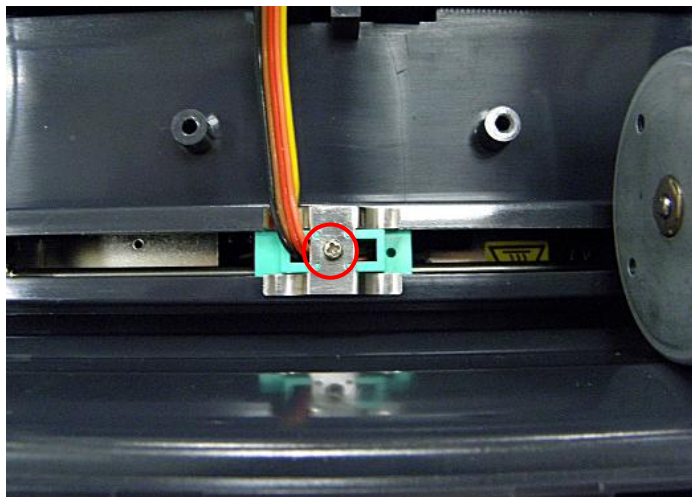

3. Remove 1 screw on the black-mark sensor fixing plate.

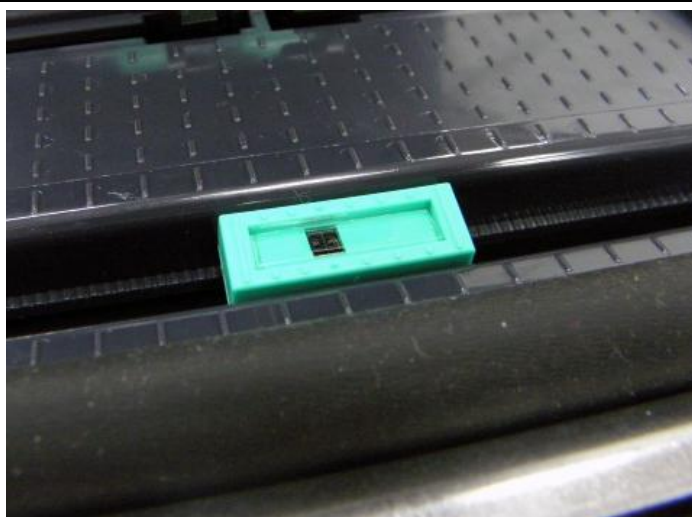

4. Remove/replace the black-mark sensor module.
5. Reassemble the parts in the reverse procedure.



### 3.8 Replacing the Gap Sensor (Transmitter)

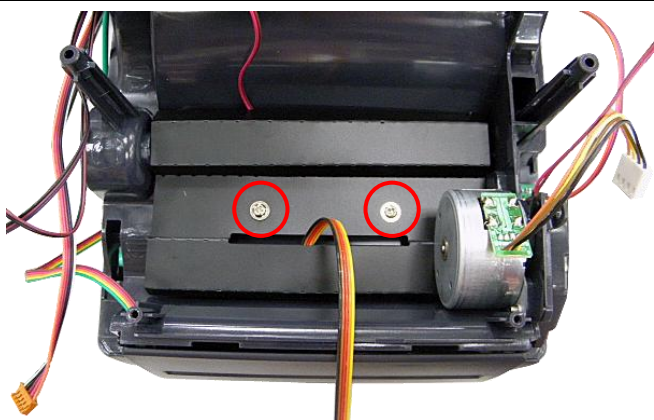

1. Refer to section 3.2 to remove the main board.
2. Remove 2 screws to release the black mylar.

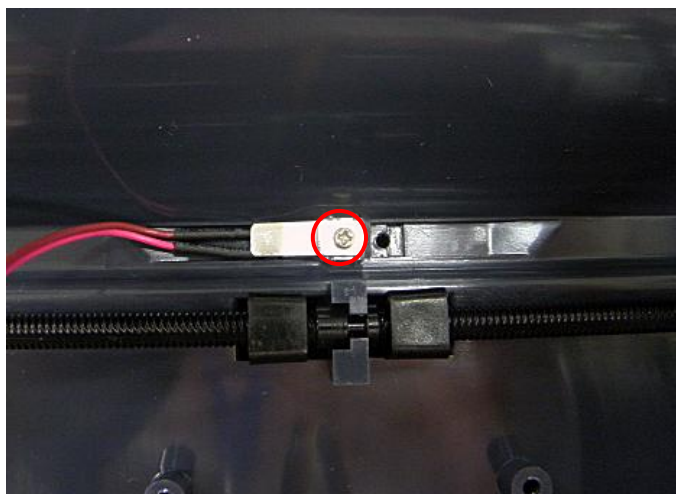

3. Remove 1 screw on the sensor fixing plate to replace the sensor PCB.
4. Reassemble the parts in the reverse procedure.

### 3.9 Replacing the Media Holder

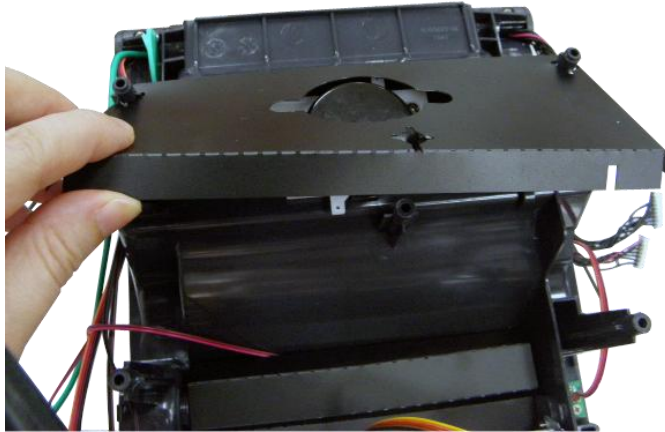

1. Refer to section 3.2 to remove the main board.
2. Remove the black mylar.

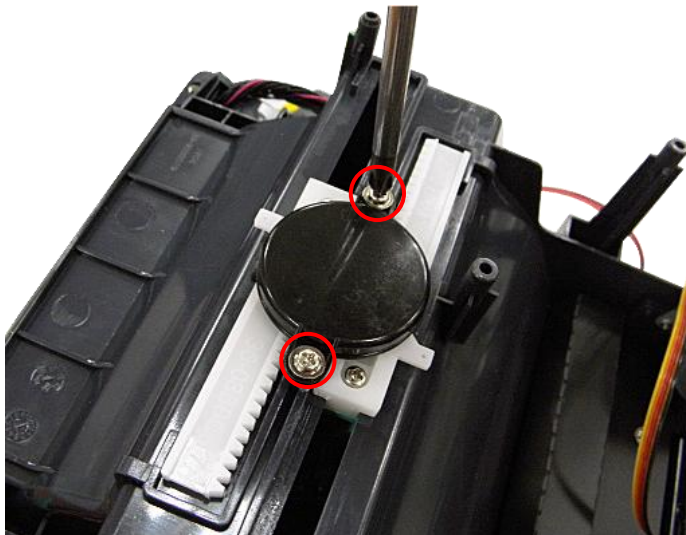

3. Remove 2 screws to take off the upper circle cover as shown.

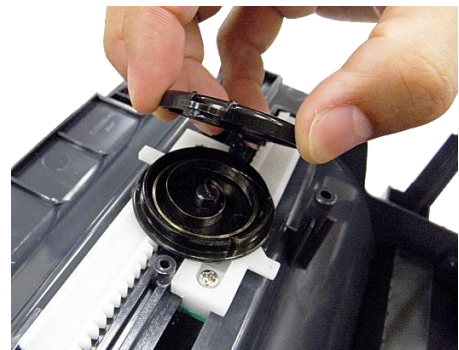

4. Press the spiral spring then take off lower circle cover. The spiral spring will be loosed in the cover.

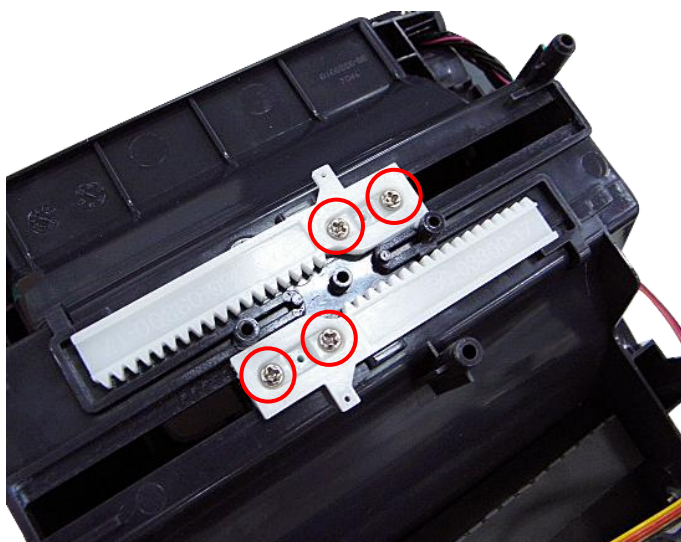

5. Remove 4 screws to replace the media holder assembly.

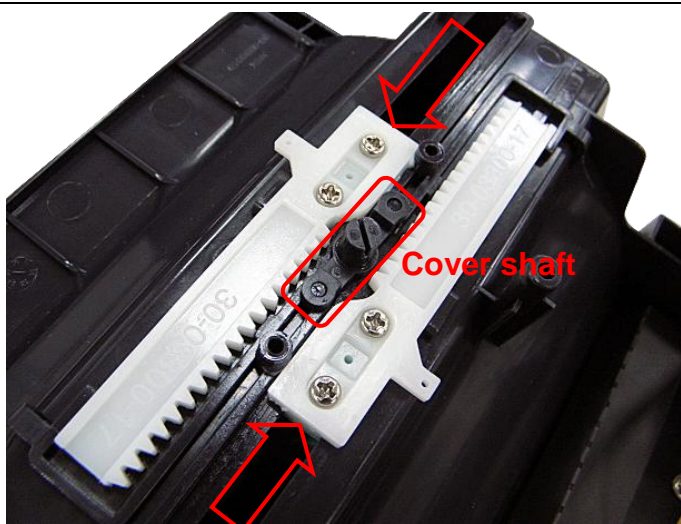
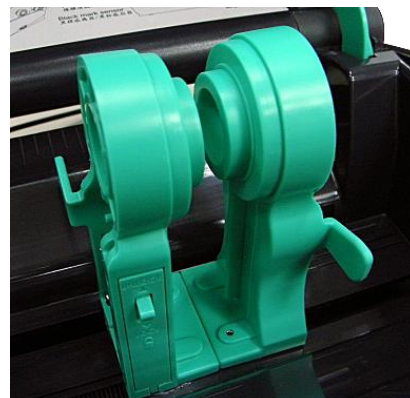

6. Push the media holder base assembly to the end place and install the cover shaft first for installing the spiral sprint assembly back.



7. Install the lower cover that including spiral sprint.



8. Use needle-nose pliers to install the spiral spring back.
9. Screw 2 screws to replace the upper cover of spiral spring assembly. Reassemble the parts in the reverse procedure.

### 3.10 Peel-off Module Installation (Option)



1. Refer to section 3.2 to remove the lower cover. Open the top cover and pull up the front panel from the printer.

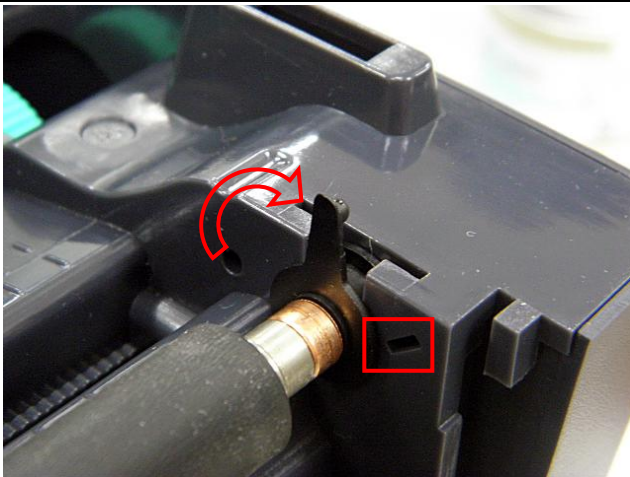

2. Disengage one of platen holder tab from lower inner cover and rotate the tab 90 degrees to install the peel-off bar into the both slots.

3. Then, rotate the tab 90 degrees to engage the platen holder tab to the lower inner cover.

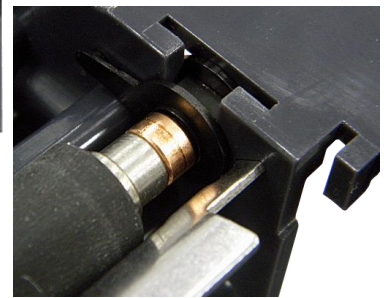
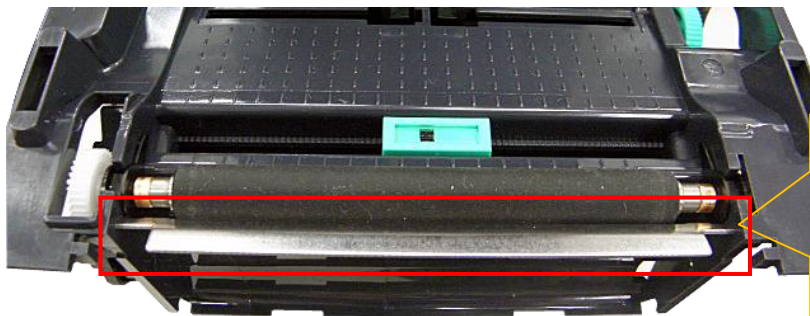

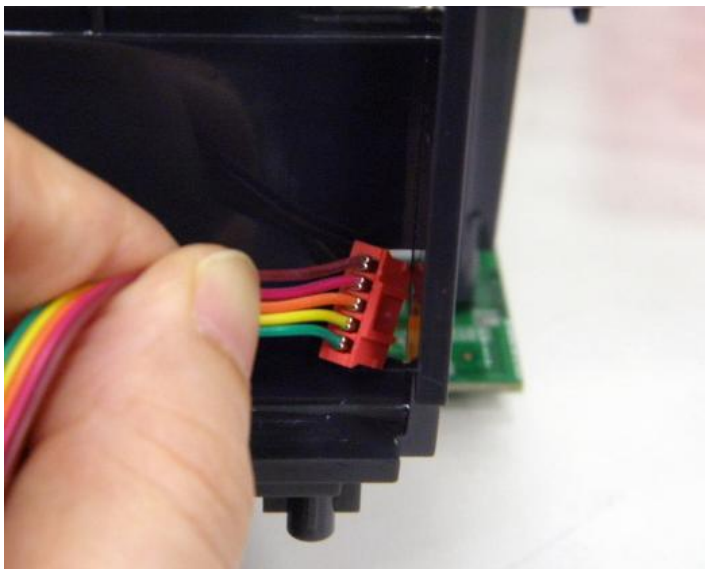

4. Thread the 5-pin peel-off module harness through the front slot of lower inner cover.

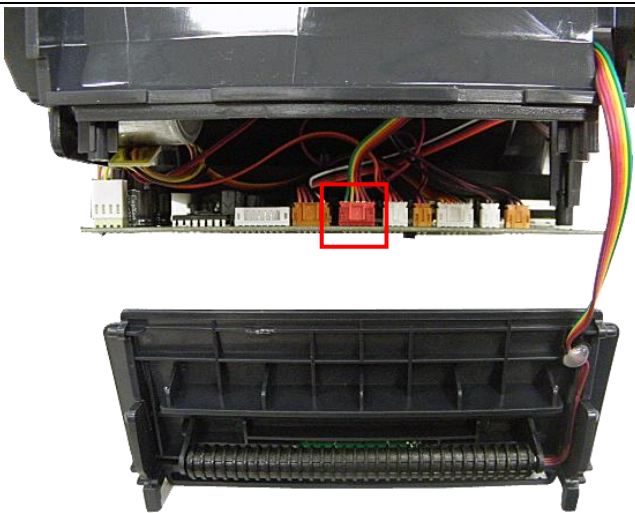

5. Plug in the peel-off module harness connector to the 5-pin red socket on the main board.

**Note:**

The connector located on J604 for TC210/TC310 series.

The connector located on JP19 for TC200/TC300 series.

6. Embed the tenons into the both sides mortise of lower inner cover and close the peel-off cover.

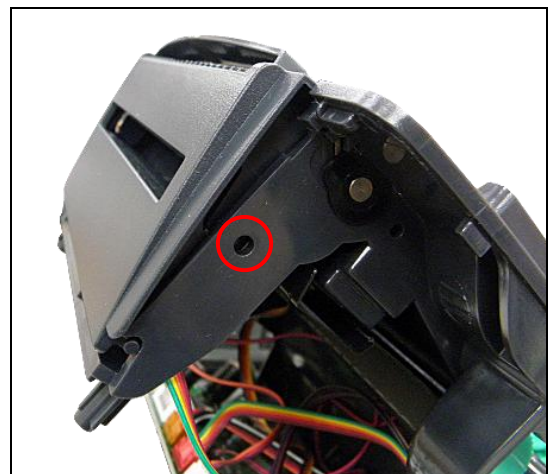
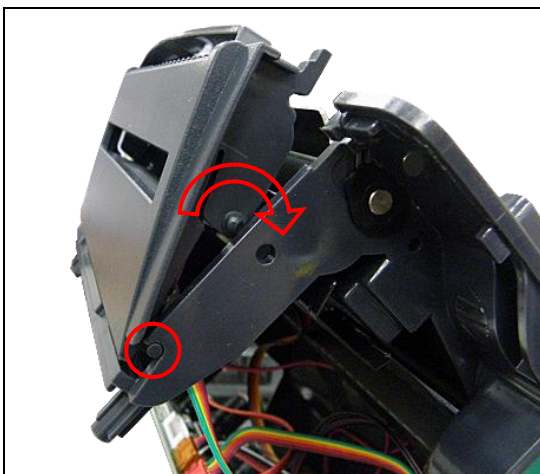



7. Put back the lower inner cover. Fasten 6 screws at the lower inner cover. Place the printer in the flat and secured desktop for media loading and printing.

**Note:**

**Please refer to user's manual for loading media in peel-off mode.**

### 3.11 Cutter Module Installation (Option)

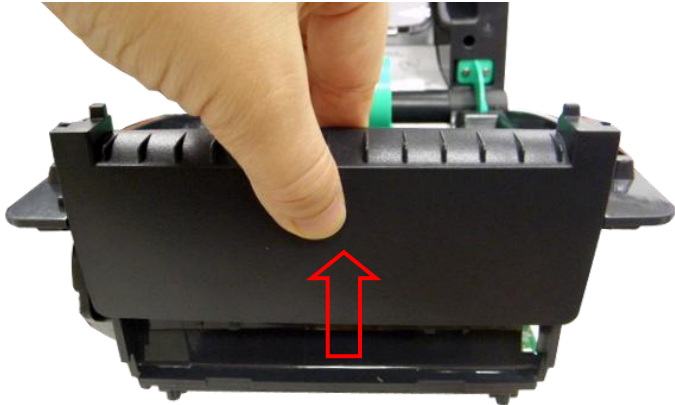
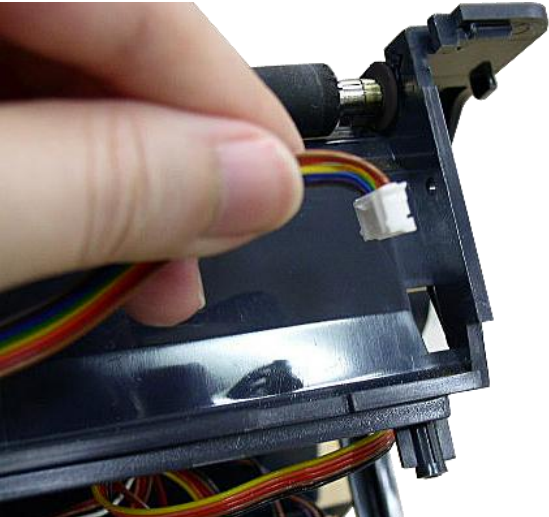
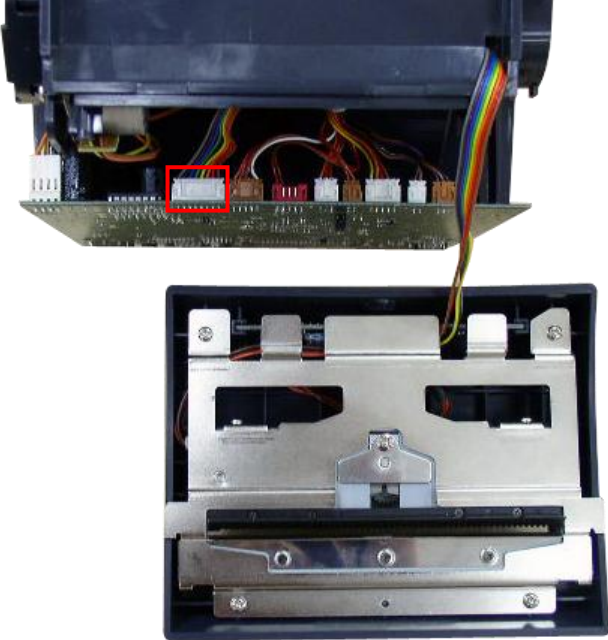
|   |   |
|---|---|
|    | <ol style="list-style-type: none"><li>1. Refer to section 3.2 to remove the lower cover. Open the top cover and pull up the front panel from the printer.</li></ol>   |
|   | <ol style="list-style-type: none"><li>2. Thread the cutter module 8-pin harness through the front slot of lower inner cover.</li></ol>  |
|  | <ol style="list-style-type: none"><li>3. Connect the cutter module harness connector to the 8-pin white socket on the printer main board.</li></ol> <p><b>Note:</b><br/>The connector located on J500 for TC210/TC310 series.<br/>The connector located on JP35 for TC200/TC300 series.</p> |



- Put back the lower inner cover. Place the cutter module into both side notches of lower inner cover as picture below, then push cutter to lock into the lower inner cover.

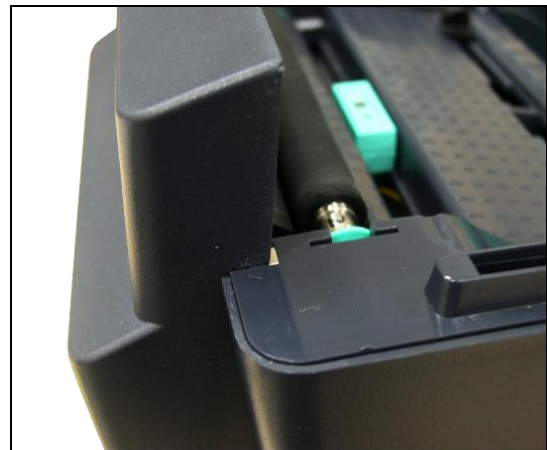
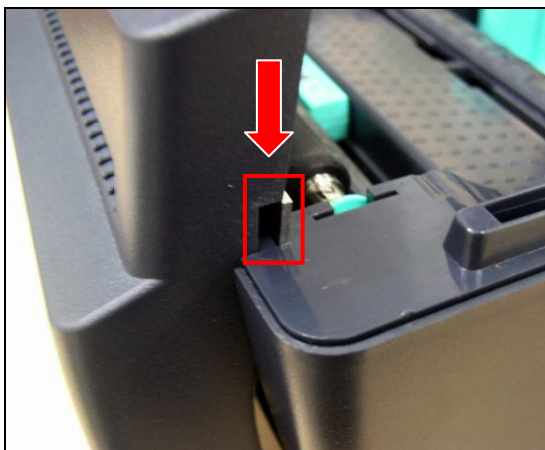
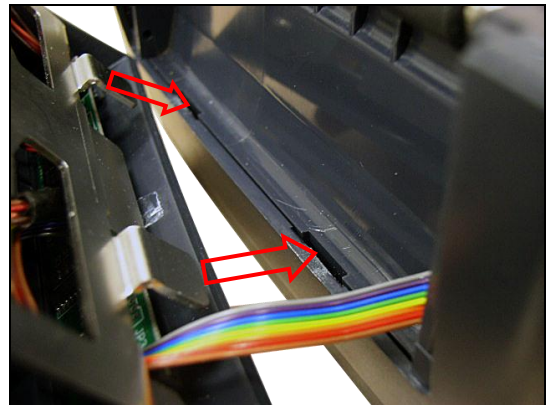
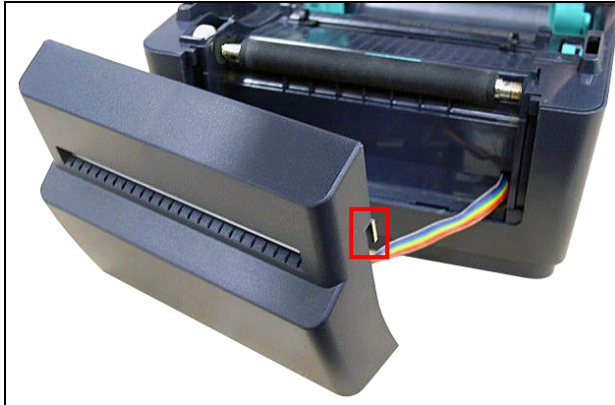

- Close the top cover and then upside down the printer.
- Fasten the 6 screws at the lower inner cover.
- Place the printer in the flat and secured desktop for media loading and printing.

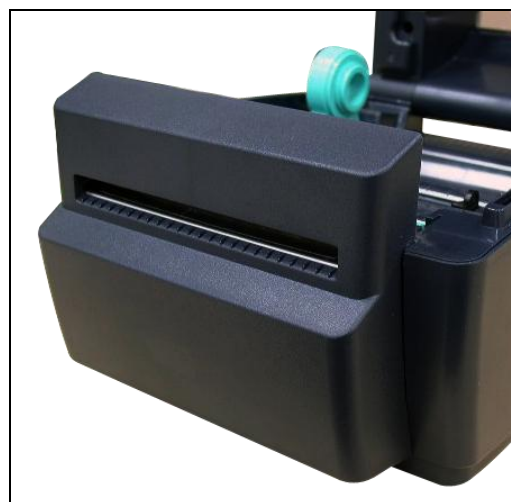

## 4. TROUBLESHOOTING

The following guide lists the most common problems that might be encountered when operating this bar code printer. If the printer still does not function after all suggested solutions have been invoked, please contact the Customer Service Department of your purchased reseller or distributor for assistance.

| Problem  | Possible Cause  | Recovery Procedure  |
|--|---|---|
| <b>Power indicator does not illuminate</b>   | * The power cord is not properly connected.   | * Plug the power cord in printer and outlet.<br>* Switch the printer on.  |
| - The printer status from DiagTool shows " <b>Head Open</b> ".<br>- The LCD shows " <b>Carriage Open</b> ".      | * The printer head is open.   | * Please close the print carriages.   |
| - The printer status from DiagTool shows " <b>Ribbon Encoder Err.</b> "<br>- The LCD shows " <b>No Ribbon</b> ". | * Running out of ribbon.<br>* The ribbon is installed incorrectly.  | * Supply a new ribbon roll.<br>* Please refer to the steps on section 3.3 to re-install the ribbon.   |
| - The printer status from DiagTool shows " <b>Out of Paper</b> ".<br>- The LCD shows " <b>No Paper</b> ".        | * Running out of label.<br>* The label is installed incorrectly.<br>* Gap/black mark sensor is not calibrated.  | * Supply a new label roll.<br>* Please refer to the steps on section 3.4 to reinstall the label roll.<br>* Calibrate the gap/black mark sensor.   |
| - The printer status from DiagTool shows " <b>Paper Jam</b> ".<br>- The LCD shows " <b>Paper Jam</b> ".          | * Gap/black mark sensor is not set properly.<br>* Make sure label size is set properly.<br>* Labels may be stuck inside the printer mechanism.                  | * Calibrate the media sensor.<br>* Set media size correctly.<br>* Remove the stuck label inside the printer mechanism.  |
| - The LCD shows " <b>Take Label</b> ".   | * Peel-off function is enabled.   | * If the peel-off module is installed, please remove the label.<br>* If there is no peel-off module in front of the printer, please switch off the printer and install it.<br>* Check if the connector is plugging correctly. |
| <b>Not Printing</b>  | * Check if interface cable is well connected to the interface connector.<br>* Check if wireless or Bluetooth device is well connected between host and printer. | * Re-connect cable to interface or change a new cable.<br>* If using serial cable,<br>- Please replace the cable with pin to pin connected.<br>- Check the baud rate setting. The default baud rate setting of printer        |

|                                     |  |  |
|-------------------------------------|--|--|
|                                     | <ul style="list-style-type: none"> <li>* The port specified in the Windows driver is not correct.</li> </ul>   | <ul style="list-style-type: none"> <li>is 9600,n,8,1.</li> <li>* If using the Ethernet cable,                             <ul style="list-style-type: none"> <li>- Check if the Ethernet RJ-45 connector green LED is lit on.</li> <li>- Check if the Ethernet RJ-45 connector amber LED is blinking.</li> <li>- Check if the printer gets the IP address when using DHCP mode.</li> <li>- Check if the IP address is correct when using the static IP address.</li> <li>- Wait a few seconds let the printer get the communication with the server then check the IP address setting again.</li> </ul> </li> <li>* Please reset the wireless device setting.</li> <li>* Select the correct printer port in the driver.</li> <li>* Print head's harness connector is not well connected with printhead. Turn off the printer and plug the connector again.</li> <li>* Check your program if there is a command PRINT at the end of the file and there must have CRLF at the end of each command line.</li> </ul> |
| <p><b>No print on the label</b></p> | <ul style="list-style-type: none"> <li>* Label or ribbon is loaded not correctly.</li> <li>* Use wrong type paper or ribbon</li> </ul>   | <ul style="list-style-type: none"> <li>* Follow the instructions in loading the media and ribbon.</li> <li>* Ribbon and media are not compatible.</li> <li>* Verify the ribbon-inked side.</li> <li>* The print density setting is incorrect.</li> <li>* Clean the print head.</li> </ul>  |
| <p><b>Poor Print Quality</b></p>    | <ul style="list-style-type: none"> <li>* Ribbon and media is loaded incorrectly</li> <li>* Dust or adhesive accumulation on the print head.</li> <li>* Print density is not set properly.</li> <li>* Print head element is damaged.</li> <li>* Ribbon and media are incompatible.</li> <li>* The print head pressure is not set properly.</li> </ul> | <ul style="list-style-type: none"> <li>* Reload the supply.</li> <li>* Clean the print head.</li> <li>* Clean the platen roller.</li> <li>* Adjust the print density and print speed.</li> <li>* Run printer self-test and check the print head test pattern if there is dot missing in the pattern.</li> <li>* Change proper ribbon or proper label media.</li> <li>* The release lever does not latch the print head properly.</li> </ul>  |
| <p><b>Cutter is not working</b></p> | <ul style="list-style-type: none"> <li>* The connector is loose.</li> <li>* Cutter jam.</li> <li>* Cutter PCB is damaged.</li> </ul>   | <ul style="list-style-type: none"> <li>* Plug in the connect cable correctly.</li> <li>* Remove the label.</li> <li>* Make sure the thickness of label is less than 0.19 mm.</li> <li>* Replace a cutter driver IC board.</li> </ul>   |

|   |   |  |
|---|---|--|
| <b>Can't downloading the file to memory (FLASH / DRAM/CARD)</b> | * The space of memory is full.  | * Delete unused files in the memory.   |
| <b>SD card is unable to use</b>                                 | * SD card is damaged.<br>* SD card doesn't insert correctly.  | * Use the supported capacity SD card.<br>* Insert the SD card again.   |
| <b>Missing printing on the left or right side of label</b>      | * Wrong label size setup.   | * Set the correct label size.  |
| <b>Gray line on the blank label</b>                             | * The print head is dirty.<br>* The platen roller is dirty.   | * Clean the print head.<br>* Clean the platen roller.  |
| <b>Irregular printing</b>                                       | * The printer is in Hex Dump mode.<br>* The RS-232 setting is incorrect.  | * Turn off and on the printer to skip the dump mode.<br>* Re-set the Rs-232 setting.   |
| <b>Label feeding is not stable (skew) when printing</b>         | * The media guides do not touch the edge of the media.  | * If the label is moving to the right side, please move the label guide to left.<br>* If the label is moving to the left side, please move the label guide to right. |
| <b>Skip labels when printing</b>                                | * Label size is not specified properly.<br>* Sensor sensitivity is not set properly.<br>* The media sensor is covered with dust.  | * Check if label size is setup correctly.<br>* Calibrate the sensor by Auto Gap or Manual Gap options.<br>* Clear the GAP/Black mark sensor by blower.               |
| <b>Wrinkle Problem</b>  | * Printhead pressure is incorrect.<br>* Ribbon installation is incorrect.<br>* Media installation is incorrect.<br>* Print density is incorrect.<br>* Media feeding is incorrect. | * Please set the suitable density to have good print quality.<br>* Make sure the label guides touch the edge of the media guide.                                     |
| <b>RTC time is incorrect when reboot the printer</b>            | * The battery has run down.   | * Check if there is a battery on the main board.   |

**The printing position of small label is incorrect**

- \* Media sensor sensitivity is not set properly.
- \* Label size is incorrect.
- \* The parameter Shift Y is incorrect.
- \* The vertical offset setting in the driver is incorrect.

- \* Calibrate the sensor sensitivity again.
- \* Set the correct label size and gap size.
- \* Use DiagTool to fine tune the parameter of Shift Y.
- \* If using the software BarTender, please set the vertical offset in the driver.

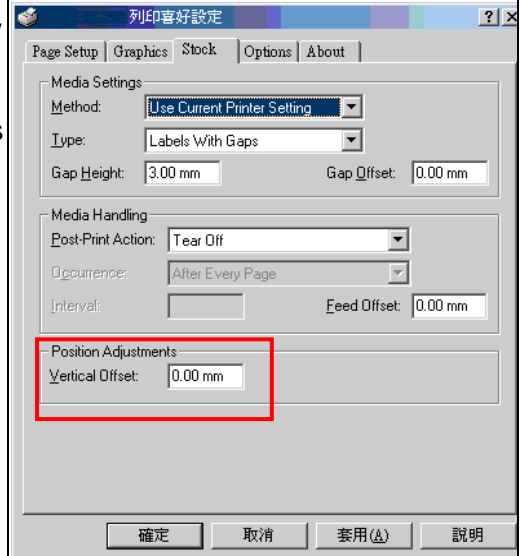

## 5. MAINTENANCE

This session presents the clean tools and methods to maintain your printer.

1. Please use one of following material to clean the printer.
  - Cotton swab
  - Lint-free cloth
  - Vacuum / Blower brush
  - 100% Ethanol or Isopropyl Alcohol
2. The cleaning process is described as following,

| Printer Part         | Method  | Interval   |
|----------------------|---|--|
| <b>Print Head</b>    | 1. Always turn off the printer before cleaning the print head.<br>2. Allow the print head to cool for a minimum of one minute.<br>3. Use a cotton swab and 100% Ethanol or Isopropyl Alcohol to clean the print head surface. | Clean the print head when changing a new label roll.   |
|                      |   |  |
| <b>Platen Roller</b> | 1. Turn the power off.<br>2. Rotate the platen roller and wipe it thoroughly with water.  | Clean the platen roller when changing a new label roll |
| <b>Peel Bar</b>      | Use the lint-free cloth with 100% ethanol to wipe it.   | As needed  |
| <b>Sensor</b>        | Compressed air or vacuum  | Monthly  |
| <b>Exterior</b>      | Wipe it with water-dampened cloth   | As needed  |
| <b>Interior</b>      | Brush or vacuum   | As needed  |

**Note:**

- Do not touch printer head by hand. If you touch it careless, please use ethanol to clean it.

- Please use 100% Ethenol. DO NOT use medical alcohol, which may damage the printer head.
- Regularly clean the print head and supply sensors once change a new ribbon to keep printer performance and extend printer life.
- Continuous printing will cause printer motor overheat. Printer will stop printing automatically about 10~15 minutes until motor is cooling down. Please don't turn off power when printer pauses or the data transfered to printer buffer will be lost.
- The maximum printing ratio per dot line is 15% for this printer. To print the full web black line, the maximum black line height is limited to 40 dots, which is 5mm for 203 DPI resolution printer and 3.3mm for 300 DPI resolution printer.

UPDATE HISTORY

| Date       | Content  | Editor  |
|------------|--|---------|
| 2015/10/21 | Modify section 1.1 (Recommended SD card specification) | Camille |
|            |  |         |
|            |  |         |
|            |  |         |
|            |  |         |
|            |  |         |
|            |  |         |
|            |  |         |
|            |  |         |
|            |  |         |





TSC Auto ID Technology Co., Ltd.

Corporate Headquarters

9F., No.95, Minquan Rd., Xindian Dist.,  
New Taipei City 23141, Taiwan (R.O.C.)

TEL: +886-2-2218-6789

FAX: +886-2-2218-5678

Web site: [www.tscprinters.com](http://www.tscprinters.com)

E-mail: [printer\\_sales@tscprinters.com](mailto:printer_sales@tscprinters.com)

[tech\\_support@tscprinters.com](mailto:tech_support@tscprinters.com)

Li Ze Plant

No.35, Sec. 2, Ligong 1st Rd., Wujie Township,  
Yilan County 26841, Taiwan (R.O.C.)

TEL: +886-3-990-6677

FAX: +886-3-990-5577